

Draft Study material



Assistant Technician Computing And Peripherals

Qualification Pack - ELE/Q4609
Sector- Electronics

Class 9th



PSS CENTRAL INSTITUTE OF VOCATIONAL EDUCATION

(A constituent unit of National Council of Educational Research and Training, under Ministry of Education, Government of India)

Shyamla Hills, Bhopal – 462002, Madhya Pradesh, INDIA

www.psscive.ac.in

© PSS Central Institute of Vocational Education, Bhopal 2024

No part of this publication may be reproduced, stored in a retrieval system or transmitted, in any form or by any means, electronic, mechanical, photocopying, recording or otherwise without the prior permission of the publisher.

PSSCIVE Draft Study Material © Not to be Published

Preface

Vocational Education is a dynamic and evolving field, and ensuring that every student has access to quality learning materials is of paramount importance. The journey of the PSS Central Institute of Vocational Education (PSSCIVE) toward producing comprehensive and inclusive study material is rigorous and time-consuming, requiring thorough research, expert consultation, and publication by the National Council of Educational Research and Training (NCERT). However, the absence of finalized study material should not impede the educational progress of our students. In response to this necessity, we present the draft study material, a provisional yet comprehensive guide, designed to bridge the gap between teaching and learning, until the official version of the study material is made available by the NCERT. The draft study material provides a structured and accessible set of materials for teachers and students to utilize in the interim period. The content is aligned with the prescribed curriculum to ensure that students remain on track with their learning objectives.

The contents of the modules are curated to provide continuity in education and maintain the momentum of teaching-learning in vocational education. It encompasses essential concepts and skills aligned with the curriculum and educational standards. We extend our gratitude to the academicians, vocational educators, subject matter experts, industry experts, academic consultants, and all other people who contributed their expertise and insights to the creation of the draft study material.

Teachers are encouraged to use the draft modules of the study material as a guide and supplement their teaching with additional resources and activities that cater to their students' unique learning styles and needs. Collaboration and feedback are vital; therefore, we welcome suggestions for improvement, especially by the teachers, in improving upon the content of the study material.

This material is copyrighted and should not be printed without the permission of the NCERT-PSSCIVE.

Deepak Paliwal
(Joint Director)
PSSCIVE, Bhopal

Date: 05 August, 2024

STUDY MATERIAL DEVELOPMENT COMMITTEE

Members

Deepak D. Shudhalwar, Professor (CSE), Head, Department of Engineering and Technology, PSSCIVE, NCERT, Bhopal, Madhya Pradesh

Member Coordinator

Deepak D. Shudhalwar, Professor (CSE), Head, Department of Engineering and Technology, PSSCIVE, NCERT, Bhopal, Madhya Pradesh

PSSCIVE Draft Study Material © Not to be Published

TABLE OF CONTENTS

S. No.	Title	Page No.
1	Module 1: Fundamental of Computer and Peripherals	1
	Module Overview	1
	Module Structure	1
	Session 1: Basic Functionality of Computer System	1
	Check Your Progress	13
	Session 2. Internal Components of Computer	15
	Check Your Progress	28
	Session 3: Input and Output Devices	30
	Check Your Progress	44
	Session 4: Storage and Peripheral Devices	46
	Check Your Progress	62
2	Module 2. Installation and Configuration Of Windows Operating System	64
	Module Overview	64
	Module Structure	64
	Session 1: Basic Of Operating System	65
	Check Your Progress	71
	Session 2: Install Windows Operating System	73
	Check Your Progress	89
	Session 3: Configure Windows Operating System	91
	Check Your Progress	121
3	Module 3. Installation and Configuration of Linux Operating System	124

	Module Overview	124
	Module Structure	124
	Session 1. Installation of Ubuntu Linux	124
	Check Your Progress	171
	Session 2. Perform Post Installation Task in Linux Operating System	173
	Check Your Progress	192
	Session 3. Install and Configure Peripheral Devices	193
	Check Your Progress	216
4	Glossary	217
5	Answers	219

Module 1**Fundamental of Computer and Peripherals****Module Overview**

Computer has become indispensable in today's life. It has become difficult to imagine the world without computer. Everywhere computers are used whether it is office, bank, school, college, business, hospitals etc. You must have seen Computers at your home, school or office.

Computer is an electronic device which accepts input, processes it and produces the desired results. Computer is a machine which performs mathematical operations and logical decisions at an extremely fast speed. Computer not only do calculations but also handles different applications at a time. In this unit, you will learn about computers, its parts, and its uses in real life.

Module Structure

Session 1: Basic Functionality of Computer system

Session 2. Internal Components of Computer

Session 3: Input and Output Devices

Session 4: Storage and Peripheral Devices

Session 1: Basic Functionality of Computer system

Computers are an essential tool of information technology (IT). They are multi-purpose machines that are used to solve a variety of problems in different fields. The basic working principle of a modern computer is based on the analytical engine designed by Charles Babbage in the 19th century. Computers have changed our daily routine as the entire task performed by us in our daily routine is automated. Our lives are directly or indirectly affected by the computers. It was in the past era where computers were used in industries. In this era of information, we are dependent on the storage, flow, and processing of data and information which can only be possible with the help of computers. This is the reason a computer is called a multi-purpose machine. The purpose of this Session is to introduce you to a computer.

Computer System

The term 'computer' is derived from the word 'compute', meaning 'to calculate'. A computer is a programmable electronic machine that accepts data from the user, processes it by

performing calculations and operations on it, and generates the desired output results. Computer performs both simple and complex operations, with speed and accuracy as shown in Figure 1.1.

Computing is not restricted to only mathematical computing but to a variety of logic-based tasks. Computer, process the data as per the given set of instructions. It can perform operations like generating bills, reserving tickets, printing mark-sheets, printing business reports, or communicating messages. Data can be text, number, audio, video, graphs, or animations.

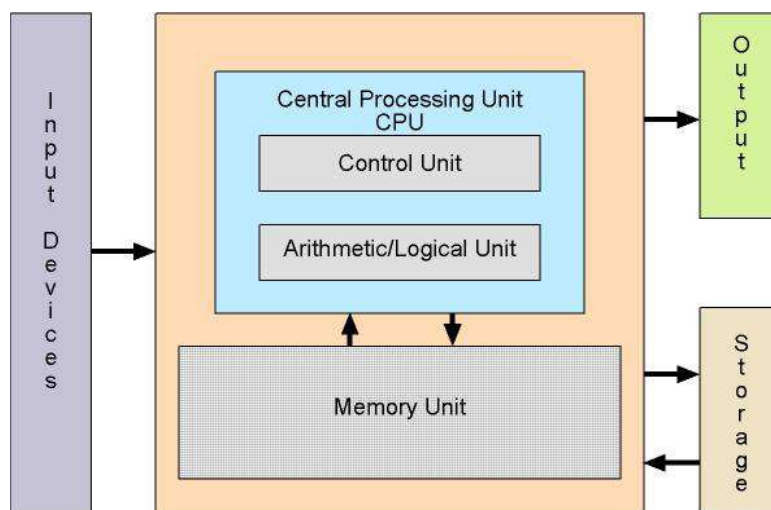

Fig. 1.1: Block diagram of computer system

Characteristics of A Computer

Speed: Computers work at very high speed and are much faster than humans. Computers can process millions (1,000,000) of instructions per second. The time taken by computers for their operations is microseconds and nanoseconds.

Storage: Computer can store large amount of data (text, video, picture etc) permanently. we can use this data at any time. computer memory storage capacity is measured in Bytes, Kilobytes (KB), Megabytes (MB), Gigabytes (GB), and Terabytes (TB).

Accuracy: When a computer performs a computation or operation, the chances of errors occurring are low. Errors in a computer are caused by human's submitting incorrect data. A computer can do a variety of operations and calculations fast and accurately.

Communication: Today's Computers have capability of communicating with other Computers. we can connect two or more computers.

Automatic: A computer as a machine cannot start itself but it can perform some work without human intervention. For example, our have large amount of data and we want to perform some calculation on it. For getting the result, we have to run the appropriate software and all the calculation will be done by Computer.

Diligence: Unlike human being, computer is free from dullness and lack of concentration. It

can work for hours without any error until job is finished.

Versatility: Versatility is a most important characteristic of computer. we may use computer to prepare salary slip and at the same time we can use the same computer for paying electricity bill and etc. It means we can perform completely different type of work on a single computer simultaneously.

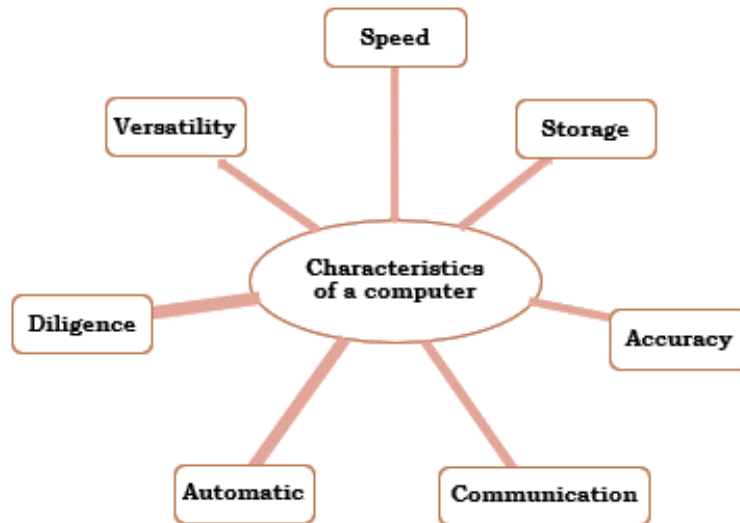

Fig. 1.2: Characteristics of a computer

Development of Computers

Development of Computers

The history of calculation is very old. In ancient times, people used their fingers to count. Later, tally sticks were used, which are considered the first counting tools. Gradually, people began using clay balls and cones to count and record numbers. Over time, counting sticks and stones were used, forming the foundation for digital counting devices. This evolution led to the invention of the Abacus, which is considered the first calculating device. With the advancement of human intelligence and technology, newer computing devices were developed.

Major Calculating Devices

- Abacus — The oldest counting device.
- Pascal's Calculator — Invented by Blaise Pascal for addition and subtraction.
- Leibniz Calculator — Could perform multiplication and division operations.
- Arithmometer — The first commercially successful mechanical calculator.
- Comptometer and Comptograph — Devices made for faster calculations.
- Difference Engine — Designed by Charles Babbage for complex calculations.
- Analytical Engine — The device that laid the foundation of the modern computer.

Mark I

A major change in the history of computers began in 1937 when Howard Aiken proposed the idea of creating a machine capable of performing large calculations. In 1944, IBM and Harvard University jointly developed the Mark I Computer. It was the first programmable digital computer, marking the beginning of a new era in computer technology.

Von Neumann Model

The architecture of computers has evolved over time. Over the past several decades, there have been many improvements in computer hardware and algorithms. However, the fundamental design concept remains the same as proposed by John Von Neumann.

Main Concept of von Neumann

A computer can store both program instructions and data in its memory. Earlier computing devices were built for specific purposes and had to be manually rewired to change their programs, which made debugging difficult. Von Neumann's design solved this problem and laid the foundation for the modern computer.

Three Main Components of von Neumann Architecture

- Central Processing Unit (CPU) — Performs calculations and controls operations.
- Memory — Stores both data and programs.
- Input/Output (I/O) Interface — Handles data input from and output to the external environment.

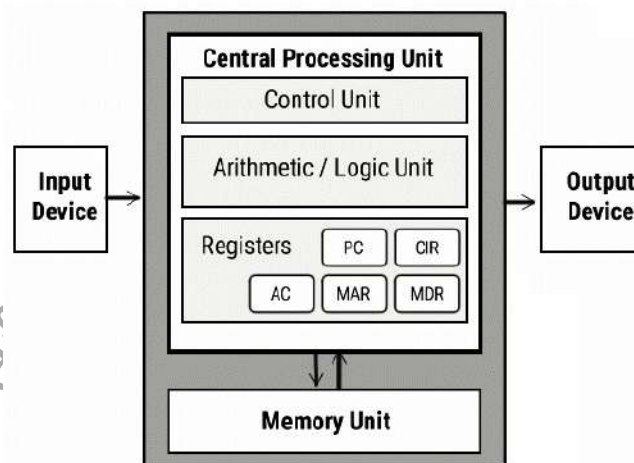

Fig. 1.3: Architecture of von Neumann

GENERATIONS OF COMPUTER

Computers were once large and slow machines, but today they have become smaller, faster, and much more powerful. The development of computers is classified into generations. Each new generation introduced new technology, making computers better, cheaper, and more efficient.

There are five main generations of computers:

First Generation (1940–1956) — These computers used vacuum tubes. They were large in size

and consumed a lot of electricity. Examples: ENIAC, UNIVAC

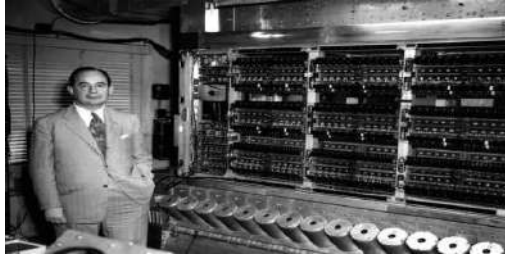

Fig. 1.4: First Generation of a computer

Second Generation (1956–1963) — These used transistors, making them smaller, faster, and more energy-efficient than earlier ones. Example: IBM 1401



Fig. 1.5: Second Generation of a computer

Third Generation (1964–1971) — These computers used Integrated Circuits (ICs), which made them even smaller, faster, and cheaper. Example: IBM 360



Fig. 1.6: Third Generation of a computer

Fourth Generation (1971–Present) — These use microprocessors, making them compact, fast, affordable, and suitable for personal use. Example: Personal Computer (PC)



Fig. 1.7: Fourth Generation of a computer

Fifth Generation (Present and Future) — These incorporate Artificial Intelligence (AI) and advanced technologies, leading to even faster, smarter, and more powerful computers.

**Fig. 1.8: Fifth Generation of a computers****Table 1.1: Generations of Computers and Their Characteristics**

Generation	Years	Main Technology	Features	Examples
First	1940–1956	Vacuum Tube	Large, slow, high power consumption	ENIAC, UNIVAC
Second	1956–1963	Transistor	Smaller, faster, lower power consumption	IBM 1401
Third	1964–1971	Integrated Circuit (IC)	Even smaller, faster, and cheaper	IBM 360
Fourth	1971–Present	Microprocessor	Compact, fast, suitable for personal use	Personal Computer (PC)
Fifth	Present and Future	Artificial Intelligence (AI)	Smart, powerful, and faster	Future AI Computers

HARDWARE AND SOFTWARE

Hardware: It consists of mechanical and electronic devices which we can see and touch. A CPU, keyboard, mouse, and monitor are examples of hardware. All the parts of the computer that you can see and touch, even those hidden inside the case, are listed below. The typical hardware for ICT may include: computer system, input/output and storage device, network card, modem, web camera, scanner, and digital camera.

Software: Programs, Operating systems, and data stored in memory and storage devices make up the system. Some example of software includes windows, Microsoft office, LibreOffice, and Photoshop. Only a computer system that includes both hardware and software is practical.

Two types of Software:

- **System Software:** Operating system such as Windows, Ubuntu etc.
- **Application Software:** MS Office (Word, Excel, Power Point), Browser (Internet explorer, Netscape Navigator),

In a human analogy the Brain is the hardware, and the thoughts are the software. A computer system is useful only if it consists of both hardware and software.



Fig. 1.9: Hardware and Software

Activity 1

Practical Activity 1.1: Identify whether the following are a part of the computer hardware or software.

Component	Hardware/Software
Motherboard	
Monitor	
DVD drive	
Hard disk	
Microphone	
MS Office "	
Keyboard	
CorelDraw	
LibreOffice	
RAM	

Tally	
MS Paint	

Classification of Computers

Generally, the word computer refers to a personal computer such as a desktop or laptop. However, we see different types of computers in our daily lives performing various tasks, for example while operating an ATM, purchasing groceries at the store, Customer servicing KIOSK available in Banks, Shopping Mall or at Railway Station. etc.

Purpose

According to purpose, computers can be classified into two types:

- General purpose computers: These computers are used for general use such as office applications, banking, invoice, sales analysis, and financial accounting. They are used at home, offices, and educational institutions.
- Special purpose computers: These computers are designed to perform scientific applications, weather forecasting, space applications, etc.

A. Based on Working principle

According to the technology used, computers can be classified into three types— analog, digital, and hybrid computers.

1. Analog computers:

These deal with analog data which represents the continuously varying physical quantities, such as current, voltage, or frequency. They are used to measure physical quantities like pressure, temperature, speed, etc., and to perform computation on these measurements. Examples are thermometer and speedometer.



Fig. 1.11: Analog Computer

2. Digital computers:

These operate on digital data. Input and output are in the form of on/ off type (digit 1 and 0). Digital computers are based on counting operation. Any data to be manipulated by a digital computer must be converted to a discrete (1,0) representation. The digital computers are mainly used in office, home, and industry.



Fig. 1.12: Digital Computer

3. Hybrid computers:

These use the combination of digital and analog computers. These computers use digital-to-analog (DAC) and analog-to-digital (ADC) technology to deal with both types of data. They store and process both analog and digital data. Hybrid computers are mainly used in artificial intelligence. The ECG machine used in hospitals is an example of hybrid computer. ECG machine reads the heart beat as an analog signal and then converts it into digital signal to print the graph.



Fig. 1.13: Hybrid Computer

B. Classification of computers according to size and storage capacity

1. Supercomputer

This is designed by interconnecting a number of processors. It has the highest processing speed with multiprocessing technology. It is mainly used in weather forecasting, biomedical research, aircraft design, remote sensing, and other areas of science and engineering. A supercomputer focuses on executing a few programs as fast as possible. Examples of supercomputers are CRAY YMP, CRAY2, NEC SX-3, CRAY XMP, and PARAM.

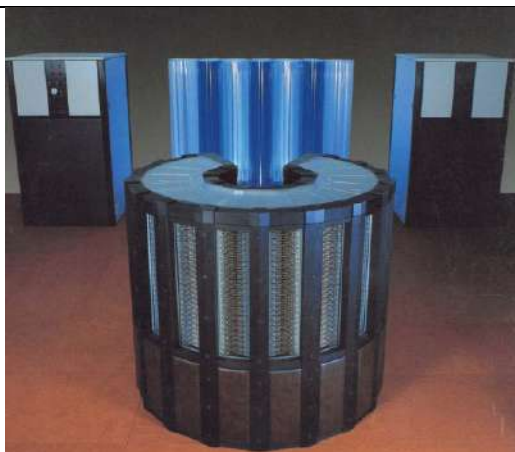

Fig. 1.14: Super Computer

2. Mainframes

These are slower than the supercomputers in speed and processing power. They can support hundreds of users simultaneously. In one way, mainframes are more powerful than supercomputers because they support more programs simultaneously, while the supercomputer can execute a single program faster than a mainframe. Mainframes have a very large storage capacity and can handle large database systems, such as patient information system in a big hospital or student information system in a university. Example of mainframes are DEC, ICL, and IBM 3000 series. The capacity of a mainframe can be a hundred or even a thousand times that of a modern PC.



Fig.1.15: main frame Computer

3. Minicomputer

This uses multiprocessing. It is capable of supporting hundreds of users simultaneously. It has a large storage capacity and operates at a higher speed. The minicomputer is used in multi-user system where various users can work at the same time. This type of computer is generally used for processing a large volume of data. It is also used as a server in Local Area Networks (LAN).



Fig. 1.16: mini Computer

4. Microcomputer

This has the lowest speed and storage capacity. Its CPU is a microprocessor. The 4-bit microprocessor chip was invented first. The 8-bit microprocessor chip was used in the first microcomputer. The microprocessor chip continues to improve 16-bit, 32 bit, and 64 bit chips. Examples of microcomputer are IBM PC, PC-AT. The PC supports a number of input and output devices. Today's microcomputer is so powerful that it can serve the purpose of a server, or sometimes that of a minicomputer that can be used as a server. The microcomputer can be categorized as below

5. Desktop computers

Desktop computers are also known as personal computer (PC). They are intended for use at a fixed location. They consist of CPU, monitor, speaker, keyboard, and mouse. Desktop computers are easy to upgrade and expand. They are also less expensive.



Fig 1.17: Desktop Computer

6. All in one computer

All in one computer are the new form of desktop PC. They have inbuilt CPU and monitor like that of a laptop. They can also have a touch screen monitor and are mounted on a desk like a standard monitor. CPU is mounted on the back side of the monitor. It has a USB port for connection of a mouse and keyboard.



Fig. 1.18: All in one computer

7. Laptop computers

A laptop has a built-in monitor, keyboard, touch-pad, and speakers to make a fully functional computer. The modern laptops also have touch screen, which minimizes the use of a keyboard or mouse. They are called laptops because of their small size and being light enough to be used while being placed on one's lap. A laptop can perform almost all jobs of a desktop. The main components of laptop are—touchpad, battery, AC adapter and ports. A user can work on a fully charged laptop without connecting it to a power supply for three to seven hours depend on battery life status. A laptop has a power cable and AC adapter designed to be used with specific type of laptop. The laptop also has 3-4 USB ports to connect peripheral devices, a VGA or HDMI port to connect the projector and a slot to insert a memory card.



Fig. 1.19: Laptop Computer

8. Mobile computers

Many mobile devices work as specialized computers. These are normally used for internet, e-mail, photography, capturing and storing images and videos. These devices are portable and consume very less space. The various mobile computers are categorized as—tablets, smartphones, wearable devices, vehicle-mounted, handheld computers, e-book readers, etc. The most common are tablets and smartphones, which are discussed here.

(i) Tablets

They are handheld computers and are more portable than laptops. They use a touch sensitive screen for typing and navigation. The size of a tablet is about 7 to 10 inches. They work on specialized operating systems such as Android, Windows, and iOS. The iPad is an example of a tablet.

(ii) Smartphones

In addition to providing telephone services, a smartphone is designed to run a variety of applications (apps). They are small tablet computers and can be used for web browsing, watching videos, reading e-books, and playing games. Many apps can be installed on the smartphone which we use in our daily lives for booking tickets, bill payment, etc.

**Fig. 1.20: Smartphone****Personal Digital Assistants (PDAs)**

They are just like a mobile phone with a touch screen and keypad. They have bigger screens than mobile phones. They use handwriting recognition software to enter text and are extremely portable and fit into pockets. They are a powerful computer that includes satellite navigation facilities (GPS), mobile phone capability, and versions of application software that have a limited range of functions.

**Fig.1.21: PDA****Summary**

A computer is an electronic machine that processes data. It works through input, processing, output, and storage operations. The main functions of a computer are to process data quickly and accurately, store large amounts of information, and deliver the required information when needed. This makes our work easier and faster.

Check your Progress**A. Multiple Choice Questions (MCQ)**

1. Who is known as the "Father of Modern Computer"? (a) John Napier (b) Blaise Pascal (c) Herman Hollerith (d) Charles Babbage
2. Which device was the earliest used for counting? (a) Pascal's Calculator (b) Abacus (c) Leibniz Calculator (d) Napier's Bones

3. The Second Generation of Computers used _____ instead of vacuum tubes. (a) Microprocessors (b) Integrated Circuits (c) Transistors (d) Silicon Chips
4. Which of the following is an example of an input device? (a) Monitor (b) Keyboard (c) Printer (d) Speaker
5. The Von Neumann architecture consists of which of the following components? (a) CPU, Memory, Input/Output (b) CPU, Registers, Modem (c) ALU, Cache, USB (d) Microprocessor, Sensors, Display

B. Fill in the Blanks

1. The word computer is derived from the word _____.
2. The first programmable digital computer was _____.
3. The _____ unit of a computer is responsible for processing data and instructions.
4. A computer's storage capacity is measured in _____.
5. A _____ computer is the fastest and used in weather forecasting and research.

C. True or False

1. Computers are free from tiredness and lack of concentration.
2. The Fourth Generation of Computers used Integrated Circuits (ICs).
3. Napier's Bones was invented in the 19th century.
4. Hybrid computers combine the features of both analog and digital computers.
5. RAM and ROM are examples of secondary memory.

D. Short Answer Questions

1. Define a computer.
2. What are the main characteristics of a computer?
3. Explain the use of Abacus.
4. Name two examples of input devices and output devices.
5. What is the difference between hardware and software?

SESSION 2- INTERNAL COMPONENTS OF COMPUTER

The motherboard is the main circuit board inside a computer. The important system components like the central processing unit (CPU) and random-access memory (RAM) modules are connected directly to the motherboard via slots or sockets designed specifically for those components. The motherboard will also provide a number of expansion slots designed to accommodate add-on cards such as video graphics adapter (VGA) cards and network interface cards (NICs). In this Chapter, we will understand the main features of the motherboard, types of motherboard, motherboard form factors, and various components of motherboard.



Fig. 2.1: Internal Components of Computer

MOTHERBOARD

The motherboard is also known as main board or system board. The motherboard connects the components of a computer and provides power to the systems that need low power. The motherboard contains a socket in which one or more processors are attached. In addition, it has slots that allow connecting peripheral cards such as video cards, sound cards, and networking cards. The internal structure of a motherboard is shown in the Figure 2.2.

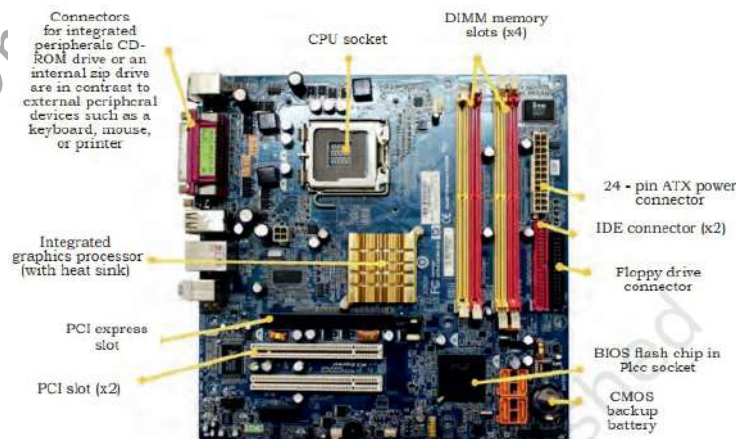

Fig. 2.2: Motherboard

Types of Motherboard

Motherboards are classified as either integrated or nonintegrated.

Integrated motherboard

This has several components integrated into the board itself. These may include the video card, sound card, and various controller cards. The maintenance is of a specific nature as the repairing of the whole board is a complex task. The integrated structure of a motherboard is shown in the Figure 2.3.

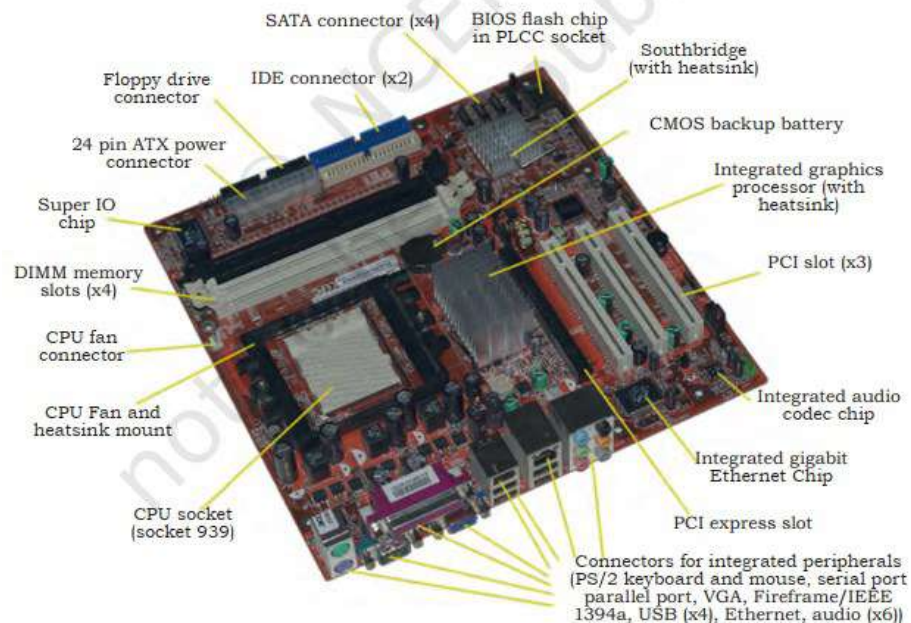

Fig. 2.3: Integrated Motherboard

Non-integrated motherboard

This motherboard uses installable components and expansion cards. In non-integrated motherboard, if any component fails, it is possible to replace that component instead of changing the entire motherboard. For example, you can remove the old video card and install a new one. Non-integrated motherboards typically have several PCI Expansion slots as well.

Basic Components of Motherboard

The modern motherboard has the following components—

- sockets (or slots) to install one or more microprocessors.
- slots to install main memory RAM.
- a chipset which forms an interface between the CPU's front side bus, main memory, and peripheral buses.
- non-volatile memory chips usually flash ROM in modern motherboards, containing the system's firmware or BIOS.
- a clock generator which produces the system clock signal to synchronise the various

components. slots for expansion cards. These interface to the system via the buses supported by the chipset.

- power connectors, which receive electrical power from the computer power supply and distribute it to the CPU, chipset, main memory, and expansion cards.

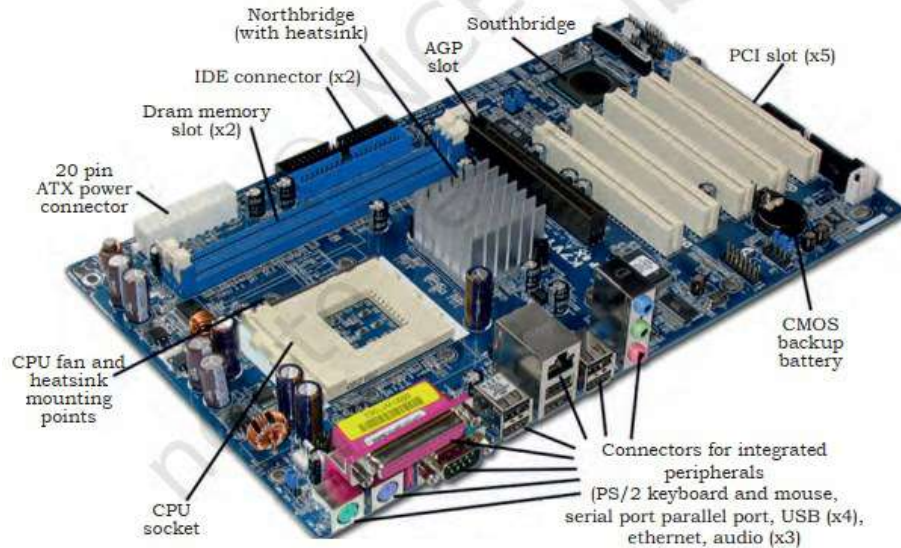

Fig. 2.4: Motherboard components

Motherboard Form Factors

Motherboards are classified by form factors. The form factor of motherboard refers to its overall dimensions and layout. Form factors essentially define the layout of the actual motherboard including the dimensions, component positioning, mounting holes, number of expansion slots, and so on. There are several different types of form factors as explained below.

Computer Motherboard Form Factors

Computer motherboards are made in different sizes and types, which are called form factors. Each form factor has a different number of expansion slots. Table 2.1 Motherboard Form Factors

Form Factor	Description
ATX	This form factor is commonly used in tower and desktop systems. It supports a maximum of seven expansion slots.
MicroATX	This form factor is a smaller version of ATX. It supports a maximum of four expansion slots.
FlexATX	This form factor is the smallest version of ATX. It supports a maximum of three expansion slots.

NLX	This form factor can be found in smaller desktop and mini towers. The number of expansion slots supported, varies.
BTX	This form factor is commonly found in newer tower and desktop systems. It supports a maximum of seven expansion slots.
PicoBTX	This form factor is the smallest version of BTX. It is commonly used in smaller low-end systems and supports a maximum of one expansion slot.
MicroBTX	This form factor is slightly smaller than the regular BTX. It is commonly found in newer mid-range systems and supports a maximum of four expansion slots.
NLX	This form factor can be found in smaller desktop and mini towers. The number of expansion slots supported varies.

CPU (Central Processing Unit)

The processor is commonly known as central processing unit or CPU. It is an electronic circuit which executes computer programs containing a processing unit and a control. A central processing unit (CPU) processes the instructions by performing the basic arithmetical, logical, and input/output operations of the system. Although the form and design of CPUs is changing with generation but its main working principle remains the same.

History of CPU

In 1971, the first microprocessor Intel 4004 was invented. It was a 4-bit calculation device with a speed of 108 kHz. A microprocessor is also known as a central processing unit in which a number of peripherals are fabricated on a single chip.

Architecture of Microprocessor

A microprocessor is a single integrated circuit (IC) chip. A number of useful functions are integrated and fabricated on a single silicon semiconductor chip. The system bus consists of data bus, address bus, and control bus for transfer of data and instructions in a proper manner. The central processing unit consists of arithmetic logic unit (ALU), registers, and control unit. Based on the registers, the generations of microprocessors can be classified. A microprocessor consists of general-purpose registers and special types of registers to execute instructions and to store the address or data while running the program. The ALU computes all arithmetic as well as logic operations on data and specifies the size of microprocessor like 16 bit or 32 bits. The memory unit holds the program as well as data and is divided into processor, primary, and secondary memory. The input and output unit interface the I/O peripheral devices to microprocessor for accepting and sending information as shown in Figure 2.5.

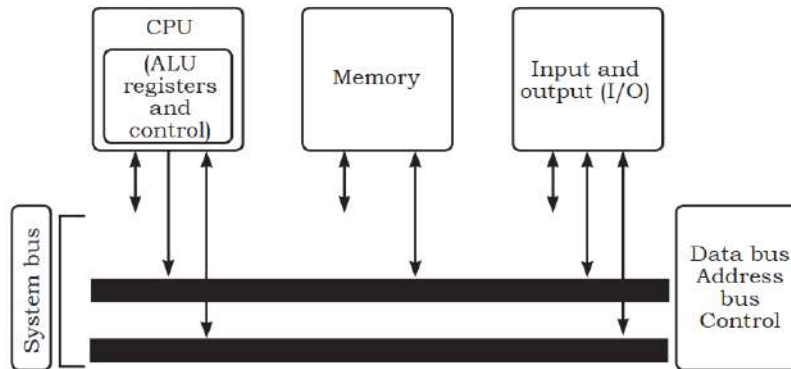

Fig. 2.5: Architecture of CPU

Generations of Microprocessors

Generation	Years	Features / Description	Examples
First Generation	1971–1973	First microprocessor created. Speed: 108 kHz.	Intel 4004
Second Generation	1973–1978	8-bit microprocessors, faster and better than first generation.	Motorola 6800, Intel 8085, Zilog Z80
Third Generation	1979–1980	16-bit processors, built using HMOS technology. Four times faster than second generation.	Intel 8086, 80186, 80286, Motorola 68000
Fourth Generation	1981–1995	32-bit processors, built using HCMOS technology.	Intel 80386, Motorola 68020/68030
Fifth Generation	1995–Present	64-bit processors, very fast and powerful.	Pentium, Celeron, Dual-Core, Quad-Core Processors

These processors include Pentium, Celeron, Dual-Core, and Quad-Core processors. A brief overview of some fifth-generation processors and their specifications is given below—

Intel Celeron- This was introduced in April 1998. It refers to a range of Intel's X86 CPUs for value personal computers. It is based on Pentium 2 and can run on all IA-32 computer programs.



Fig. 2.6: Intel Celeron processor

Pentium

This was introduced on March 2 in 1993 after Intel 486, the 4 here in 486 indicates the fourth generation.

Pentium refers to Intel's single core x86 microprocessor which is based on the fifth-generation micro-architecture. This processor's name was derived from the Greek word 'penta' meaning 'five'. The Pentium MMX with a data bus of 64 bits was developed in 1996. More improved versions of pentium processors were designed from the year 2000.



Fig. 2.7: Pantium Celeron processor

Xeon

This is a 400 MHz Pentium processor from Intel for use in workstations and enterprise servers. This processor is designed for multimedia applications, engineering graphics, internet, and large data base servers.



Fig. 2.8: Xeon processor

Functions of a CPU

A CPU or processor carries out certain instructions and manipulates data. The main function

of a CPU is to execute a sequence of stored instructions called a program. It can execute only machine code and fetches the machine coded instructions from memory and executes them. CPU processes instructions in four steps—fetch, decode, execute, and write back.

Fetch- The CPU reads data and instruction from memory.

Decode- The data and instructions are decoded to determine what action is required.

Execute- The instructions are executed by performing arithmetic or logical operation on data.

Write- The result of an execution is written to memory or an I/O module.

Concept of Program Execution

The instructions to be executed by a computer are loaded in sequential locations in its main memory. To execute instructions, the CPU fetches one instruction at a time and performs the functions specified. Instructions are fetched from successive memory locations until the execution of a branch or a jump instruction.

The CPU keeps track of the address of the memory location where the next instruction is located through the use of a dedicated CPU register, referred to as the program counter (PC). After fetching an instruction, the contents of the PC are updated to point at the next instruction in sequence as shown in Figure 2.9.

For simplicity, let us assume that each instruction occupies one memory word. Therefore, execution of one instruction requires the following three steps to be performed by the CPU:

1. fetch the contents of the memory location pointed out by the PC (program counter). The instructions are stored in the instruction register (IR).
2. increment the contents of the PC by 5.
3. carry out the actions specified by the instruction stored in the IR.

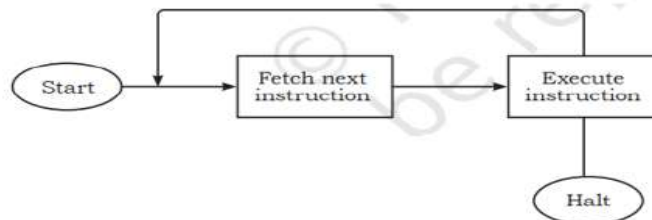

Fig. 2.9: Basic instruction cycle

The first two steps are the fetch phase and step three is the execution phase. Fetch cycle involves reading of the next instruction from the memory into the CPU and updating the contents of the program counter. In the execution phase, it interprets the opcode and performs the indicated operation. The instruction fetch and execution phase together are known as the instruction cycle. The instruction cycle is shown in the Figure 1.29.

In cases where an instruction occupies more than one word, step one and step two can be repeated as many times as necessary to fetch the complete instruction. In these cases, the execution of an instruction may involve one or more operands in memory, each of which requires a memory access. Further, if indirect addressing is used, then additional memory

accesses are required.

Major components of the CPU:

The three major components of the CPU are— arithmetic and logic unit (ALU), control unit (CU), and registers.

Arithmetic and logic unit (ALU): This performs arithmetic and logical operations. For example, it can add together two binary numbers either from memory or from some of the CPU registers.

Control unit: This controls the action of the other computer components so that instructions are executed in the correct sequence.

Registers: These are temporary storage inside the CPU. It is internal memory of CPU which can read and write at a high speed. It is used to hold data and instructions temporarily while processing. It also holds the location of the last instruction. With this it can find the location of the next executable instruction.

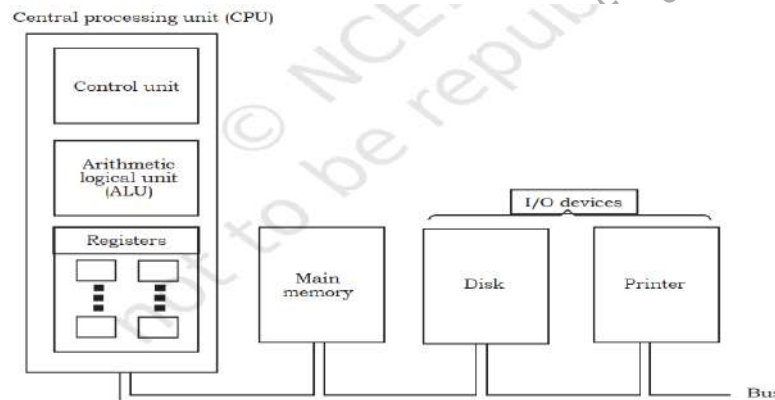

Fig. 2.10: Major components of the CPU

Activity 1

Practical Activity 2.1 Installation/Connectivity of CPU

The CPU and motherboard are sensitive to electrostatic discharge. So, place them on a grounded anti-static mat and wear an anti-static wrist strap while handling the CPU. When handling a CPU, do not touch the CPU contacts at any time. The CPU is secured to the socket on the motherboard with a locking assembly.

Thermal compound which is used to conduct heat away from the CPU is applied on top of the CPU. In case of an old CPU, first clean the top of the CPU and then apply the thermal compound. Clean the top of the CPU and the base of the heat sink with isopropyl alcohol and a lint free cloth. This removes the old thermal compound. Then apply a new layer of thermal compound.



Fig.2.11: Installing CPU on the motherboard

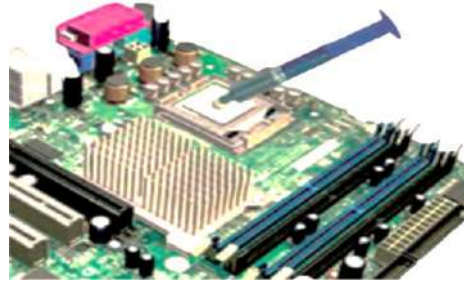

Fig. 2.12: Applying thermal compound on CPU

CPU heat sink

This is an important component of a modern computer. It is an attachment for the chip that prevents it from overheating. The computer's CPU operates at high speed, which causes it to heat up quickly. If the CPU gets too hot, the computer may shut down and could get damaged. A heat sink is used to keep the CPU cool. It is a metal device that draws heat away from the CPU and releases it outside. Usually, a fan is attached to the heat sink to expel hot air. Heat sinks are mostly made of copper and aluminum because these metals help dissipate heat efficiently:

- Copper — Excellent conductor of heat but heavy.
- Aluminum — Lighter than copper and does not put much load on the motherboard.

Some computers also use a liquid cooling system, which uses a special liquid to remove heat. The liquid is pumped to a radiator to expel the heat.

Main functions of a heat sink:

- Protect the CPU
- Prevent excessive heating
- Ensure the computer runs properly for a long time

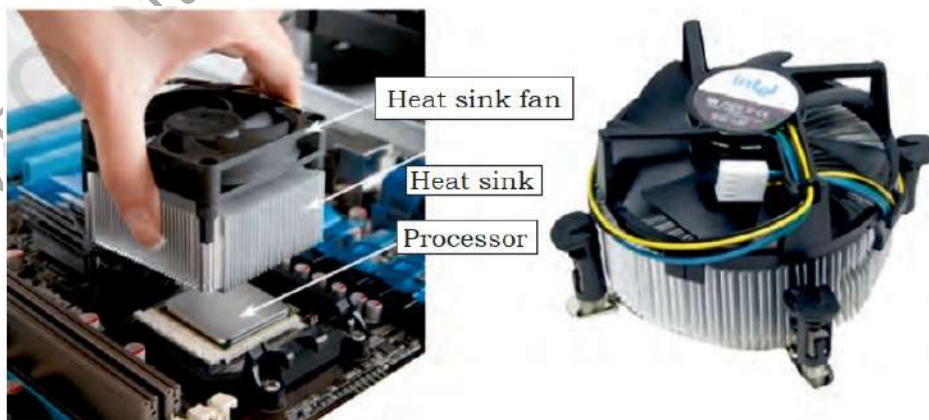

Fig. 2.13: Heat sink with cable and connector

Activity 3

Practical Activity 2.2 Installation of heat sink

Heat sink and fan assembly: Heat sink is a cooling device. The heat sink draws heat away from the CPU. The fan moves the heat away from the heat sink. The assembly has a 3-pin power connector. Figure 1 shows the cable and the motherboard connector for the heat sink.



Fig. 2.14.: Screwing the heat sink

To install a CPU fan and heat sink, follow these steps:

- align the heat sink and fan assembly with the holes on the motherboard.
- screw in the heat sink.

Primary storage

In a computer, primary storage is also called main memory. It is the part of the computer where program instructions and data currently in use are stored. It is located on the motherboard and allows fast reading and writing of data, enabling the processor to work quickly.

Need for Primary Storage

- Fast Data Access — Provides quick access to data and programs, speeding up operations.
- Temporary Storage — Data remains here only while the computer is running.
- Loading Operating System — The operating system is loaded into primary storage when the computer starts.
- Running Applications — Software and apps run in primary storage.
- Faster Performance — Frequently used data is kept nearby for quick access.
- Buffering — Temporarily holds data and delivers it to the processor at the correct speed.
- Computation and Processing — Handles temporary data generated during program execution.
- CPU Support — Provides the CPU with instructions and data instantly.
- Better Performance — Ensures smooth and fast computer operation.

Types of Primary Storage

Primary storage in a computer consists of different types of memory, each with distinct functions and characteristics.

1. Read-Only Memory (ROM) — Data in ROM can only be read, not modified; it is permanent memory. Booting instructions are stored in ROM to start the computer.

Types of ROM:

- PROM (Programmable ROM) — Data can be written only once.
- EPROM (Erasable PROM) — Can be erased using ultraviolet (UV) light and rewritten.
- EEPROM (Electrically Erasable PROM) — Data can be erased and rewritten multiple times, but it is slower.
- MROM (Masked ROM) — Data is pre-written and cannot be changed.

2. Random Access Memory (RAM) — RAM is temporary memory. Data remains in RAM only while the computer is on; it is erased when the computer is turned off. Data can be read and written in RAM.

Types of RAM:

- Dynamic RAM (DRAM) — Requires periodic refreshing of data. Slower but inexpensive.
 - Static RAM (SRAM) — Provides faster access to data. Expensive and used in cache memory.
3. Flash Memory — A non-volatile memory, meaning data remains safe even when the computer is off. Used in pen drives, memory cards, and SSDs.
 4. Cache Memory — Located very close to the CPU and works very fast. Stores data that the CPU frequently needs, further speeding up computer performance.

Types of Primary Storage in Table 2.2

Type of Memory	Volatile / Non-Volatile	Features	Example / Use
Read-Only Memory	Non-volatile	Data can only be read and cannot be changed.	Booting process to start the computer
Random Access Memory	Volatile	Data remains only while the computer is powered on.	Programs or apps are loaded into RAM when run
Flash Memory	Non-volatile	Can be erased and re-written multiple times. Data remains safe when the computer is off.	Pen drives, memory cards, SSDs
Cache Memory	Volatile	Located near the CPU and works very fast. Stores frequently used data needed by the CPU.	Used to increase CPU speed and overall performance

HDD (Hard disk drive)

A computer hard disk drive (HDD) is a non-volatile data storage device. Non-volatile refers to storage devices that maintain stored data when turned off. All computers need a storage

device, and HDDs are just one example of a type of storage device.

HDDs are usually installed inside desktop computers, mobile devices, consumer electronics and enterprise storage arrays in data centers. They can store operating systems, software programs and other files using magnetic disks.

More specifically, hard disk drives control the reading and writing of the hard disk that provides data storage. HDDs are used either as the primary or secondary storage device in a computer. They are commonly found in the drive bay and are connected to the motherboard via an Advanced Technology Attachment (ATA), Serial ATA, parallel ATA or Small Computer System Interface (SCSI) cable, among other formats. The HDD is also connected to a power supply unit and can keep stored data while powered down.

SSD (Solid State Drive)

Solid-state drive (SSD) is a solid-state storage device that uses integrated circuit assemblies as memory to store data. SSD is also known as a solid-state disk although SSDs do not have physical disks. There are no moving mechanical components in SSD. This makes them different from conventional electromechanical drives such as Hard Disk Drives (HDDs) or floppy disks, which contain movable read/write heads and spinning disks. SSDs are typically more resistant to physical shock, run silently, and have quicker access time, and lower latency compared to electromechanical devices.

It is a type of non-volatile memory that retains data even when power is lost. SSDs may be constructed from random-access memory (RAM) for applications requiring fast access but not necessarily data persistence after power loss. Batteries can be employed as integrated power sources in such devices to retain data for a certain amount of time after external power is lost.

Difference Between SSD and HDD

Table 2.3 Difference between SSD and HDD

HDD	SSD
HDDs are more reliable for long-term storage.	SSDs are comparatively less reliable for long-term storage due to data leaks that can occur if kept unpowered for more than a year.
The data accessing speed is slower as compared to SSD.	The data accessing speed is much higher as compared to HDD.
The performance suffers because of fragmentation.	The performance does not suffer because of fragmentation.
HDDs are suitable for <ul style="list-style-type: none"> • Extensive storage • Long-term storage 	SSDs are suitable for <ul style="list-style-type: none"> • Fast data retrieval • Laptop or desktop because of low power consumption and size.

Graphics Card

The Graphics Card, also referred to as a Video Adapter, is an essential component that enhances a personal computer's display capabilities by plugging into an expansion slot on the motherboard. It facilitates the transmission of visual data to the monitor, enabling users to interact with the computer through graphical interfaces. Two primary display modes are supported: text mode, which displays ASCII characters, and graphics mode, which renders bit-mapped images. Unlike older setups where the computer's RAM handled display storage, modern graphics cards incorporate dedicated memory, alleviating the burden on system resources. Furthermore, advanced graphics cards boast their own graphics coprocessors, often termed graphics accelerators, designed to efficiently handle complex graphics calculations, resulting in smoother and more immersive visual experiences for users.



Fig. 2.15.: Graphics card

sound card

Sound cards are indispensable components within personal computers, seamlessly integrating into expansion slots to deliver immersive audio experiences. They serve as the conduit between digital data and the vibrant sounds emanating from speakers, translating binary signals into rich, analog audio waves. Crucial for multimedia endeavors, they enable the seamless playback of CD-ROMs and enhance gaming experiences with dedicated connections for peripherals. Moreover, their versatility extends to recording capabilities, effortlessly capturing sound input from microphones for various applications. In essence, sound cards serve as the auditory backbone of modern computing, bridging the gap between digital information and tangible, resonant.

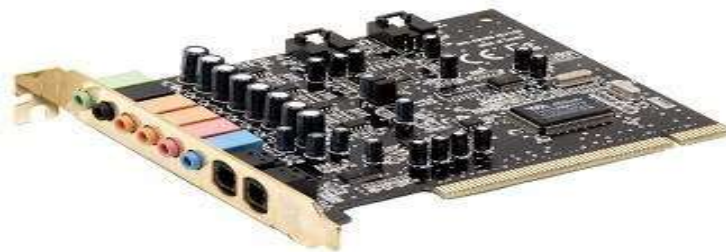

Fig. 2.16.: sound card

Power supply

The Switch Mode Power Supply (SMPS) serves as the primary power supply unit for computer systems, delivering the low voltage DC power essential for their operation. This vital component ensures the steady provision of power ranging from 5 to 12 volts, meeting the diverse energy needs of various system components and peripherals. Through its efficient conversion of alternating current (AC) to direct current (DC) at different voltage levels, the SMPS enables the stable and reliable functioning of the computer, powering critical components such as the motherboard, processor, memory modules, and peripherals. Its compact design and advanced switching technology not only optimize power delivery but also minimize energy loss and heat generation, contributing to the overall performance and longevity of the computer system. Thus, the SMPS plays a crucial role in sustaining the functionality and efficiency of modern computing devices.

Summary

The main internal components of a computer include the motherboard, CPU, RAM, hard disk, and others. The CPU is the brain of the computer and performs all calculations. RAM is temporary memory that holds data while the computer is running, and the hard disk provides permanent data storage. The combined operation of all these components ensures the computer functions properly.

Check Your Progress**A. Multiple choice questions (MCQs)**

1. Which is called the brain of the computer? (a) RAM (b) CPU (c) Motherboard (d) Hard Disk
2. Which component connects all the internal parts of a computer? (a) Motherboard (b) Graphics Card (c) Storage Device (d) Sound Card
3. A graphics card is mainly used for (a) Sound processing (b) Video and image rendering (c) Data storage (d) Internet connectivity
4. Which device stores data permanently even when the power is off? (a) RAM (b) ROM (c) Storage Device (HDD/SSD) (d) CPU
5. Expansion slots on the motherboard are used for (a) Adding extra keyboard (b) Connecting USB drives (c) Storing files (d) Installing add-on cards like graphics and sound cards)

B. Fill in the blank questions

1. ----- is the main circuit board of a computer.
2. ----- performs arithmetic and logical operations inside the CPU.

3. ----- is high-speed storage that retains data even without power.
4. A ----- improves visuals and graphics quality in games or design software.
5. ----- allows the computer to process and output audio.

C. True or False

1. CPU is directly connected to the motherboard.
2. Sound card is used for audio processing, not displaying visuals.
3. Storage devices like HDD and SSD store data permanently.
4. Graphics cards are connected to the motherboard via expansion slots.
5. RAM is a type of volatile (temporary) memory.

D. Short Questions

1. What is the function of the motherboard?
2. Name the main parts of the CPU.
3. Why is a graphics card important for gaming?
4. Difference between RAM and ROM?
5. What is the role of a sound card in a computer?

Session 3. Input and Output Devices

Input and output devices are required to communicate with the computer. These devices are connected to the CPU through various ports or with the help of wireless technologies. Input devices feed data and instructions into the computer, and output devices present information from a computer system. Output generated

by the output devices may be hardcopy or softcopy output. Hardcopy outputs are permanent outputs which can be used later when required. They produce a permanent record on paper. Printer is a common output device, that produces hardcopy outputs. Softcopy outputs are electronic and are available on the screen in a digital form. They do not produce a permanent record. Monitor is a common softcopy output device.

INPUT DEVICES

An input device is used to feed data into a computer. It is also defined as a device that provides communication between the user and the computer.

3.1.1 Text Input Devices

These are the devices which are commonly used to give text input to the computer like alphabets, numbers and other special symbols etc.

1. Keyboard: This is the most common input device. It is designed just like a conventional typewriter. It allows the user to input alphabets, numbers, and other characters. It provides keys for additional functions. It detects the key being pressed and generates the corresponding ASCII code which can be recognized by the computer. The standard US keyboard introduced in 1986 has 101 keys. It has a keyboard layout called the QWERTY design. QWERTY gets its name from the first six letters across in the upper left-hand corner of the keyboard as shown in Figure 3.1.



Fig. 3.1: Keyboard

2. Numeric keypad

It is a small keyboard having only numbers. It is used to enter only numeric data such as those in ATMs. The computer keyboards also have a numeric keypad as shown in Figure 3.2.



Fig. 3.2: Numeric Keyboard

3. PIN pad

This is a device with a numeric keypad used to enter a personal identification number (PIN) of debit card or credit card while doing the transaction as shown in Figure 3.2.



Fig. 3.3: PIN pad

3.1.2 Pointing Devices

These devices are used to move an onscreen pointer or cursor (usually an arrow). They are commonly used with graphical user interfaces (GUIs).

1. Mouse

It is a small handheld device used to indicate the position of a cursor or its movement on a computer's screen by rolling it over a mouse pad or flat surface. A mouse has one or more buttons and possibly a scroll wheel. This scroll wheel is used to scroll the screen vertically or horizontally. The different types of mouse are ball, optical, and laser mouse. Ball mouse works on the principle of the movement of the ball, whereas optical mouse uses LED and laser mouse uses laser beams for sensing the movement. Laser mouse has more precise movement when compared to other types of mouse. Wired mouse uses serial, PS/2, and USB ports, to communicate, as shown in Figure 3.4, 3.5 and 3.6. Whereas a wireless mouse communicates with the computer via radio waves.



Fig. 3.4: Wireless Mouse



Fig 3.5: USB port Mouse



Fig. 3.6: PS2 Port Mouse

2. Light Pen: It is a pointing device shaped like a pen. The tip of the light pen contains a light-sensitive element which when placed against the screen detects the light from the screen,

enabling the computer to identify the location of the pen on the screen. Light pens have the advantage of drawing directly on the screen. They are used by engineers, artists, and fashion designers for Computer Aided Designing (CAD) and other drawing purposes.



Fig. 3.7: Light pen

3. Touch Screen: It is an input device that allows the user to operate by simply touching on the display screen. Some computers, tablets, smartphones, etc., have touch-sensitive display screens. It can also be operated using a stylus which gives more precision. Information kiosks at railway stations and bank ATMs also use touch screens as input device. Nowadays, touch screens are the most common hardware interface for electronic gadgets.



Fig. 3.8: Touch Screen

4. Graphic Tablet: This consists of an electronic writing area and a special pen that works with it. It allows artists to enter natural hand movements to create graphical images with motions and actions similar to traditional drawing tools. A stylus is used like a pen and moved over the surface of the tablet. Stylus' movement data is then sent to the computer. The pen of the graphics tablet is pressure sensitive. Hard or soft pressure on the tablet using the pen can result in brush strokes of different widths in an appropriate graphics program.



Fig.3.9: Graphic tablet

5. Touchpad: This is a pointing device found on the laptop computers in place of a mouse to control the pointer. It allows the user to move the finger across the touchpad just as a

mouse pointer does and this movement in the form of data is sent to the computer. Touchpad is operated with fingers and dragging it across the flat surface, as the finger moves on the surface, the mouse cursor will move in that same direction. The touchpad also has two buttons below the touch surface that enables clicking.



Fig. 3.10 Touchpad

6. Joystick: This is an input device used for playing video games, controlling training simulators and robots. Joysticks and other game controllers can also be used as pointing devices. The joystick has a vertical stick which can move in any direction. It can be used to control objects in a video game or to make menu selections by the movement of a cursor displayed on the screen. It has a button on the top that is used to select the option pointed by the cursor.



Fig. 3.11 Joystick

3.1.3 Audio Visual Input Devices

Audio-visual input devices are essential components of modern computing systems, facilitating the interaction between users and computers through audio and visual mediums. These devices capture and transmit data in the form of sound, images, or video, enabling users to communicate, create, and interact with digital content.

1. Scanner

Scanning is a process of taking a close-up photograph. Scanner is an input device which functions like a photocopying machine. It has a glass plate to place the paper which is to be scanned. Scanners can capture information, like pictures or text, and convert it into a digital format that can be edited using a computer. The scanned image or document is captured by the laser beams and converted to digital data. The scanned picture or document can be saved in the computer. The quality of the image depends on the resolution of the scanner. The resolution of the image scanned is expressed in dots per inch (DPI). The higher the DPI, the better will be the resolution of the scanned image.

The different variants of scanners are flat bed, sheet feed, and hand-held scanner. A sheet feed scanner can scan a single sheet, whereas a flatbed can scan even from a book but they are not portable. A hand-held scanner is portable but the scanning action is not smooth as the scanner is moved manually.



Fig. 3.12 Scanner

2. Microphone

This is used to input human voice into the computer. It is attached to a computer for the input of sound. It accepts sound which is analogue in nature as input and converts it to digital format. The digitized sound can be stored in the computer for processing or playback. The headphones come with microphones to use chat applications. A computer loaded with speech recognition software like the one pre-installed in Windows 7 can convert what a person has said into text, which can be saved for word processing. A voice recognition program can process the input and convert it into machine recognizable commands.



Fig. 3.13 Microphone

2. Digital camera

This can take pictures and videos and convert them into digital format. Pictures or videos taken using a digital camera are stored inside its memory and can be transferred to a computer by connecting the camera to it. It is a kind of small computer that controls camera focus, stores images, etc. It runs a very simple operating system (stored on ROM) and usually provides a menu-based GUI for the user.



Fig. 3.14 Digital Camera

The quality of the lens, the density of charge coupled device (CCD), resolution (measured in megapixel), optical zoom, and the software used in the camera determines the quality of the

picture. Each picture is made up of thousands of tiny pixels (picture elements) and the camera stores the data on the colour of each dot. The quality of the picture is determined by the number of pixels in each picture. Digital cameras have resolutions ranging from 2 mega pixel to 24 megapixels and optical zoom ranging from 3x to 60x.

4. Webcam

It is a compact and less expensive version of a digital camera. It is used in computers for video chatting. It does not have an internal memory. It is a very basic video camera used to feed live video into a computer. The video data from a web cam is low quality compared to a full video camera. It is positioned on top of the laptop monitor and for desktop computers it can be connected externally. Applications like Skype, Yahoo Messenger, etc., use webcam to capture images. Now, laptops also come with an inbuilt web camera.



Fig. 3.15 Webcam

5. Closed circuit TV (CCTV)

CCTV captures the images and videos fed as input to the computers. (Figure 3.16). CCTVs are commonly used to maintain road safety and the security on premises.



Fig. 3.16 Closed Circuit TV

3.1.4 Input card Readers

1. Smart card or chip reader

This is a plastic card that stores and transacts data. It has a tiny 'chip' of computer memory embedded inside. Data can be stored in the chip's memory and read back using a 'chip' reader. The data card may contain a memory or a microprocessor. Memory cards simply store data, while a microprocessor card on the other hand can add, delete, and manipulate information in its memory. The smart card is used in most banking, healthcare, telephone calling, electronic cash payments, and other applications.



Fig. 3.17 Smart card or chip reader

Smart card readers are used to access data in a smart card. It can be contact type or contact less. A contact type of reader requires physical contact with the cards, which is made by inserting the card into the reader. A card is inserted into the reader where metal contacts connect to the metal pads on the front face of the card. The reader can access the data stored on memory chip. A contact less type of reader works with a radio frequency that communicates when the card comes close to the reader. Many contact less readers are designed specifically for toll gate payment in transportation applications and person identity applications. Satellite TV decoders use smart cards to store data regarding subscription of channels by the user. The data is encrypted so that it is not easy to alter. Many types of cards—ID cards, phone cards, credit cards, and door security cards use this system.

2. Magnetic strip reader

The credit cards have a magnetic strip. This strip stores the user's data in the form of magnetized dots (for example, the credit card number, card expiry date, and customer name). The strip allows inputting of this data to a computer system faster and more accurately than typing. A magnetic strip reader is used to read the data by swiping the card through a slot on the reader.



Fig. 3.18 Magnetic strip reader

3.1.5 Input-reading Text or Codes

Entering the data in a computer using a keyboard may be a slow process and it is prone to mistakes. Sometimes speed and accuracy may be essentially required. In such cases, the following input devices are used to read and input the data.

1. Barcode & Quick Response (QR) code reader

It is a set of vertical lines of different thickness and spacing that represent a number. These lines are read by a barcode reader or scanner. Barcode readers are devices that are used to input data from such set of barcodes (Figure 3.18). This code is converted to an alphanumeric

value and is fed to the computer connected to it. The bar code reader reads and enters the value quickly and accurately than entering the data by using a keypad. Barcode is used to code items in a shop and books in a library. Handheld scanners are commonly seen in shops to scan codes and price information for each of the items to make billing easier. Mobile phones with camera and special software can also be used as a barcode reader.



Fig. 3.19: Bar Code



Fig. 3.20: Quick Response (QR) Code

QR codes are similar to barcodes. Barcodes are single dimensional, whereas QR codes are two dimensional as shown in Figure 3.20. The two-dimensional way of storing data allows QR code to store more data than a standard barcode. This code can store website URLs, plain text, phone numbers, email addresses, and any other alphanumeric data. The QR code can be read using a barcode reader or a mobile phone which has a camera and special software installed.

2. Optical Mark Reader (OMR)

It is an input device that recognizes marks made by a pencil or pen in a multiple-choice type form. It is commonly used to check forms filled with pen or pencil and to correct MCQs of exam papers. It can read the marks and feed that data to a computer (Figure 3.21).

OMR technology scans a printed form and reads predefined positions and records the marks on the form. This technology is useful for applications in which large number of forms needs to be processed quickly with great accuracy, such as objective type tests and questionnaires.



Fig. 3.21: Optical Mark Reader (OMR)

3. Magnetic Ink Character Reader (MICR)

It reads the data written by the magnetic ink. The cheque number is printed at the bottom of each bank cheque by special magnetic ink using a special font. It can be detected by a MICR reader. MICR reads this data and feeds it to the computer quickly and accurately.



Fig. 3.22: Magnetic Ink Character Reader (MICR)

4. Optical Character Recognition (OCR)

This is a software technology that converts images of text into an actual text file. To use this technology, first scan the document using the scanner. Then the scanned image is analyzed by the OCR software. The result is such that it seems the text has been typed by hand.



Fig. 3.23: Optical Character Recognition (OCR)

3.1.6 Input Sensors

A sensor is a device that senses the real-world data (for instance, temperature) and converts it into digital data to be processed by the computer. A computer system cannot sense the real-world data such as light or dark, hot or cold, quiet or noisy. We use our senses (eyes, ears, mouth, nose, and skin) to read such data. In the same way, the sensor reads this kind of data and converts it into its digital equivalent. The sensors are connected to a computer.

Biometric sensor

It is a device that identifies unique human physical features with high accuracy. It is an essential component of a biometric system which uses physical features like fingerprints, retina, iris patterns, etc., to identify, verify, and authenticate the identity of the user. The three major types of biometric sensors are semiconductor sensor, optical sensor, and ultrasound sensor. Figure 3.23 shows a biometric sensor.



Fig. 3.24 Biometric sensor

3.2 Output Devices

These can be categorized into three types based on the output produced by the computer in the following form:

1. Soft copy
2. Hard copy
2. Sound output

3.2.1 Soft copy output device

The output on the screen is called a soft copy. The soft copy output can be provided on the following devices.

Visual Display Unit (VDU)

This is an output device that visually conveys text, graphics, and video information. Information shown on a display device is called softcopy because the information exists electronically and is displayed for a temporary period of time.

Display devices include Cathode Ray Tube (CRT) monitors, Liquid Crystal Display (LCD) monitors, Thin Film Transistor (TFT) monitors, Light Emitting Diode (LED) monitors, and gas plasma monitors.

Flat panel monitors

These are very thin, lightweight, and need very less power. Flat panel displays are thinner, lighter in weight, consume less power, and emit less heat as compared to CRT monitors. They are most commonly used in computers, especially in laptops. Different types of flat panel monitors are LCD (Liquid Crystal Display), LED (Light Emitting Diode) and OLED (Organic LED). LCD uses liquid crystal molecules for display, LED uses light emitting diodes for display, and OLED uses a special organic compound for display. LED displays have better brightness.



Fig. 3.25: Flat panel monitor

Liquid crystal display (LCD): This display consists of liquid crystals sandwiched between two plastic plates. These crystals rearrange to form an image when an electric current pass through them. A light source at the back of this plate makes the picture visible. This light source can be a fluorescent lamp or LED.



Fig. 3.26: Liquid crystal display (LCD) monitor

Light emitting diode (LED) monitor:

This uses LED directly behind the liquid crystal display (LCD) in order to light up the screen. This technique is very effective and gives each area of the screen its own light, which can be on or off. LED screens can produce massive contrast ratios resulting in better color quality and clarity. Further, wider viewing angle, faster refresh rates, and power saving are its other advantages, making this technology expensive.



Fig. 3.27: Light emitting diode (LED) monitor

Plasma monitors: A flat panel display consists of sandwiching neon or xenon gas between two sealed glass plates with parallel electrodes deposited on their surfaces. When a voltage pulse is passed between two electrodes, the gas lights up as different colours creating images on a monitor. Plasma monitors provide high resolution but are also expensive.



Fig. 3.28: Plasma monitor

Organic light emitting diode (OLED) monitors: The panel of OLED is made up of millions of tiny LEDs. The 'O' in OLED stands for organic which means there is carbon in the light emitting layer of the panel. OLED screens are thinner and lighter than LCDs and LEDs. They

can produce better quality images and have a better viewing angle. OLEDs consume less power but are again very expensive.



Fig. 3.29: Organic light emitting diode (OLED) monitors

LCD projector

This is a type of video projector used for displaying videos, images, or computer data on a large screen or any other flat surface. Several people in a classroom can view the output on a wide screen at the same time. It is a modern equivalent of the slide projector or overhead projector. A beam of high-intensity light travels through thousands of shifting pixels in a LCD display. This beam of light then passes through a lens which projects and focuses the image on the surface.



Fig. 3.30: LCD projector

3.2.2 Hard copy output devices

Hard copies are tangible computer outputs. Printer and plotter are used to get a hard copy output.

Printer

The function of a printer is to print the information from a computer onto paper. The quality of a printer depends on its resolution (DPI) and speed. Speed is measured in characters per second (CPS), lines per minute (LPM), or pages per minute (PPM).

Based on technology, printers are of two types:

- 1. Impact Printers**
- 2. Non-Impact Printers**

(1) Impact Printers

These printers print by striking a ribbon with pins or print heads against the paper, which produces noise.

- **Dot Matrix Printer** — It uses small pins that strike the ribbon to form characters. The print quality is low, and it makes considerable noise, but it can produce multiple copies simultaneously. These printers are commonly used in shops and billing counters.



Fig. 3.31: Dot Matrix Printer

- **Line Printer** — Similar to a dot matrix printer, but it prints an entire line at once. It works very fast and is used in large offices and organizations.



Fig. 3.32: Line Printer

(2) Non-Impact Printers

These printers do not touch the paper while printing and are therefore quiet.

- **Inkjet Printer** — It sprays tiny droplets of ink through nozzles to create text or images. The print quality is high, and it is used for photo printing. These printers are inexpensive, but ink cartridges can be costly.
- **Laser Printer** — It uses a laser beam and toner powder to produce very clear and fast prints. These are commonly used in offices and schools. Color laser printers are more expensive.



Fig. 3.34: Laser Printer

- **Thermal Printer** — It prints on heat-sensitive paper using heat. These printers are small, lightweight, and consume very little power. They are used for printing receipts in ATMs and shops.



Fig.3.35: Thermal Printer

The features of all the above printers are summarized in the Table 3.1.

Type of Printer	Technology	Speed	Quality	Uses
Dot Matrix Printer	Prints characters using pins and ribbon	Slow	Low	Shops and cash counters
Line Printer	Prints one complete line at a time	Very fast (up to 3000 LPM)	Medium	Large offices and companies
Inkjet Printer	Sprays droplets of ink	Medium	Very good (photo-like)	Home, photo printing
Laser Printer	Uses laser beam and toner powder for printing	Fast	Very clear and sharp	Offices, schools, professional work
Thermal Printer	Prints using heat on heat-sensitive paper	Fast	Average	ATMs, shop receipts, label printing

3.3.3 Sound output device

The device which gives a sound output is called a speaker. Speaker devices are designed for personal and public use.

The audio output is the ability of the computer to produce sound. Speakers are the output devices that produce sound. They are connected to the computer through audio ports. They produce sound by the movement of the diaphragm in the speaker, forward and backward according to the electrical signals coming out of the audio port. For high quality sound reproduction, computers use 2.1 (3 speakers), 5.1 (5 speakers), and 7.1 (7 speakers) speaker systems.



Fig. 3.35: Speaker

Summary

Input devices such as the keyboard and mouse provide information to the computer. On the other hand, output devices such as the monitor and printer display or print the processed information. The importance of these devices lies in the fact that they enable us to communicate with the computer and retrieve information.

Check Your Progress

A. Multiple choice questions (MCQs)

1. Which of the following is a text input device? (A) Mouse (B) Keyboard (C) Printer (D) Scanner
2. Which of the following is a pointing device? (A) Monitor (B) Scanner (C) Mouse (D) Microphone
3. Which of the following is an audio-visual input device? (A) Scanner (B) Keyboard (C) Microphone (D) Printer
4. Which device is used for input-reading text or codes? (A) Printer (B) Scanner (C) Mouse (D) Monitor
5. Which of the following is a soft copy output device? (A) Printer (B) Monitor (C) Plotter (D) Speaker
6. Which device is considered a hard copy output device? (A) Speaker (B) Monitor (C) Plotter (D) Scanner
7. Which device is commonly used for reading data from credit or debit cards? (A) Scanner (B) Keyboard (C) Microphone (D) Magnetic Stripe Reader

B. Fill in the blank questions

1. _____ are used for entering text, such as letters, numbers, and symbols, into a computer system.
2. A _____, such as a mouse or touchpad, allows users to interact with graphical user interfaces by moving a pointer on the screen.

3. _____ capture both audio and visual data, such as videos or live streams, and input them into a computer system.
4. _____ are devices used to read data from magnetic stripes or chips, commonly found in credit cards or identification cards.
5. Devices capable of _____ are able to interpret and input text or codes, such as those found on barcodes or QR codes.
6. _____ produce visual or auditory output that can be viewed or heard on a screen or speakers connected to the computer.
7. A _____ produces output that is displayed on a screen or monitor, allowing users to view digital content.
8. A _____ is a type of output device that produces sound or audio output, allowing users to listen to music, voice recordings, or system alerts.

C. True or False

1. A keyboard is an example of a pointing device.
2. Input card readers are used to read data from magnetic stripes or chips, commonly found in credit cards.
3. Output devices produce data that can be physically touched or held.
4. Soft copy output devices produce physical copies of data, such as printed documents.
5. Input sensors detect and input physical phenomena into a computer system.
6. Hard copy output devices produce output that can be viewed on a screen or monitor.
7. Pointing devices allow users to interact with graphical user interfaces by moving a pointer on the screen.
8. Text input devices are only capable of inputting handwritten text.

D. Short Questions

1. What are text input devices? Provide examples.
2. What are audio visual input devices? Provide an example.
3. What is the function of input card readers? Give an example of their application.
4. What are input sensors? Give an example of their use.
5. Define output devices. Give two examples.
6. Explain the difference between soft copy and hard copy output devices. Provide examples of each.
7. What is the purpose of a sound output device? Give an example.
8. How do input devices contribute to the functioning of a computer system?

Session 4. Storage and Peripheral Devices

Digital Data Storage Devices

The digital storage devices market has experienced remarkable growth in recent years, driven by the exponential increase in data generation and the growing demand for data storage and management solutions. Characterized by a diverse range of products, including hard disk drives (HDDs), solid-state drives (SSDs), USB flash drives, and memory cards, this industry has seen significant advancements. SSDs, in particular, have surged in popularity due to their superior performance, faster data transfer speeds, and enhanced reliability compared to traditional HDDs. Furthermore, the need for higher storage capacities and compact devices has fueled the development of microSD cards and NVMe SSDs. Furthermore, with the widespread adoption of cloud computing and the Internet of Things (IoT), the digital storage devices sector is poised for further expansion and innovation.

Memory or storage devices

Memory is required in a computer to store programs and the data processed by programs. Computer memory is made up of a large number of cells. Each cell is capable of storing one bit of information in the form of binary numbers.

Capacity and measuring unit of Memory

In the realm of computing, memory capacity is a crucial concept often discussed in terms of various measuring units. Memory capacity refers to the amount of data that a memory storage device can hold. It is typically measured in units such as bytes, kilobytes (KB), megabytes (MB), gigabytes (GB), terabytes (TB), and beyond. These units represent increasing orders of magnitude, with each subsequent unit being exponentially larger than the previous one. For instance, a byte is the smallest unit of memory, capable of storing a single character, while a kilobyte can hold approximately a thousand bytes of data, and so on. Understanding memory capacity and its measuring units is essential for effectively managing digital data and selecting appropriate storage devices to meet specific needs.

The storage capacity of the memory is expressed in various units of memory. These are as follows:

Table 4.1 for Computer Data Storage Memory Unit.

Unit	Description
Bit (Binary Digit)	A binary digit is logical 0 & 1
Nibble	1 Nibble = 4 bits
Byte (B)	1 Byte = 8 bits
Kilobyte (KB)	1 KB = 1024 B
Megabyte (MB)	1 MB = 1024 KB

Gigabyte (GB)	1 GB = 1024 MB
Terabyte (TB)	1 TB = 1024 GB
Petabyte (PB)	1 PB = 1024 TB
Exabyte (EB)	1 EB = 1024 PB
Zettabyte (ZB)	1 ZB = 1024 EB
Yottabyte (YB)	1 YB = 1024 ZB

Memory System

Memory in a computer system is required for the storage and subsequent retrieval of instruction and data. A computer system uses a variety of devices for storing instructions and data required for its operations. Normally, the information to be stored on a computer is classified in two basic categories – data and instructions.

Although a memory system is a very simple system, it exhibits a wide range of technology. But unfortunately, faster memory is more costly. On the other hand, memories with smaller cost have very high access time. This is the time taken by the CPU to access a location in memory. This results in slower operation of the CPU. Thus, the cost versus access time has led to a hierarchy of memory where we supplement fast memories with larger, cheaper and slower memories. Therefore, memory system may have different types, costs, organizations, technologies and performances. (Figure 4.1)

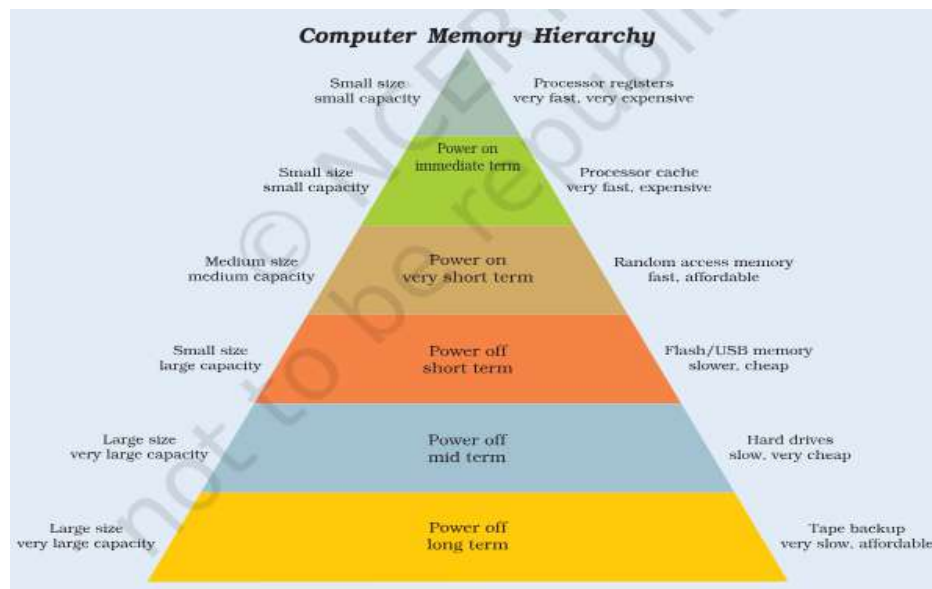

Fig. 4.1 The Memory Hierarchy

Types of Memory

A memory system can be considered to consist of three types of memories. These are as follows:

1. Internal processor memories
2. Primary memory or main memory
3. Secondary or auxiliary memory

Any storage unit of a computer may have the following characteristics:

Storage capacity is the amount of information/data a storage unit can hold. Accessing the data to/from these memories may be fast or slow.

The speed and availability of inexpensive memory has had enormous impact on computer technology. The highspeed memory devices are more expensive and occupy less space in comparison to the slow speed memory devices.

Internal Processor Memories

These consist of the small set of high-speed registers and highspeed buffer memory (cache) which are internal to a processor and are used as temporary locations where actual processing is done.

Register is a small amount of storage available on the CPU whose contents can be accessed more quickly than storage available elsewhere. Processor registers are at the top of the memory hierarchy and provide the fastest way for a CPU to access data.

Cache Memory

Cache memory is a small highspeed buffer memory used to hold instructions temporarily during processing.

The CPU of a computer system commonly uses cache memory (Figure 4.2) where it holds or buffers the contents of the main memory because the CPU runs much faster than the main memory. Thus, to reduce the waiting time of the CPU the cache is used. Cache memory reduces traditional system bottlenecks because system RAM is much slower than CPU. This prevents the processor from having to wait for a program and data from slower main memory.

A cache typically operates by retaining copies of blocks of storage, each containing recently used information. This memory (or caches) is usually transparent or invisible to the processor.

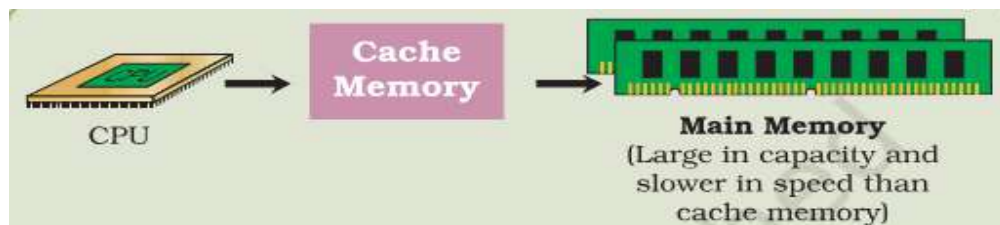

Fig. 4.2 Cache memory

Cache is a collection of data duplicating original values stored elsewhere or computed earlier, where the original data is expensive to fetch (owing to longer access time) or to compute, compared to the cost of reading the cache. In other words, a cache is a temporary storage area where frequently accessed data can be stored for rapid access. Once the data is stored in the cache, future use can be made by accessing the cached copy rather than prefetching or

recomputing the original data, so that the average access time is reduced.

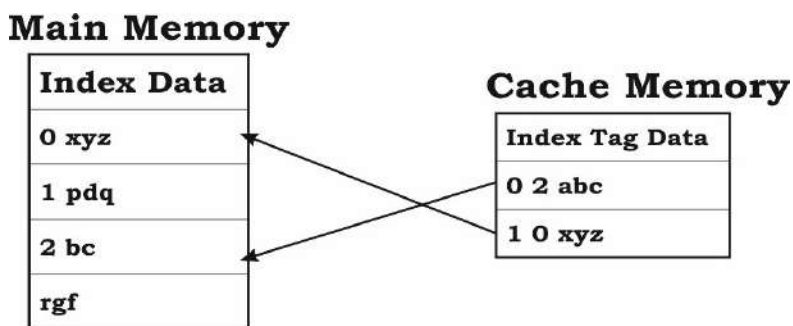

Fig. 4.3 CPU memory cache

Primary Memory

Primary memory is the main memory of a computer. The CPU can directly read and write data in it. It is essential for the functioning of the computer. It is divided into two parts – ROM and RAM.

Read Only Memory (ROM)

ROM stands for Read Only Memory. The data in ROM can only be read but cannot be modified. The essential programs required to start the computer are stored in ROM.

Types of ROM:

- PROM (Programmable ROM): Data can be written only once.
- EPROM (Erasable PROM): Data can be erased using ultraviolet (UV) light.
- EEPROM (Electrically Erasable PROM): Data can be erased and modified electrically.
- Flash Memory: The entire block or chip can be erased and rewritten at once.

Random Access Memory (RAM)

RAM stands for Random Access Memory. It is called temporary memory because when the computer is turned off, the data in RAM is lost. It provides data to the CPU at high speed.

Types of RAM:

- SRAM (Static RAM): Faster but more expensive. It retains data as long as power is supplied.
- DRAM (Dynamic RAM): Cheaper and has higher capacity but needs to be refreshed frequently.

Table 4.2 Comparison between ROM and RAM

ROM	RAM
Read Only Memory	Random Access Memory
It stores information permanently.	It holds information temporarily.
Information is not lost even if the	Information is lost when power supply is

computer is switched off.	switched off.
Known as non-volatile memory.	Known as volatile memory
Holds system software such as Boot Loader.	Holds operating system and application programs which are currently in use.
Types of ROMs are PROM, EPROM EEPROM.	Type of RAMs are Dynamic RAM and Static RAM.

Secondary Memory

Secondary memory is also called auxiliary memory. It is slower than the main memory but has a larger storage capacity. It is long-term and non-volatile, meaning the data remains safe even when the power is turned off. The processor cannot use it directly. It is used to store programs and data for a long time and to create backups.

Types of Secondary Memory

Floppy Disk

It is a magnetic disk, available in 5¼-inch and 3½-inch sizes. Its storage capacity was very low (up to 1.44 MB). It was slow and less reliable but inexpensive and portable.

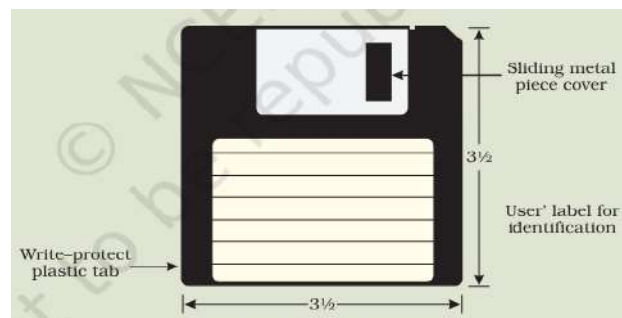

Fig. 4.4 Floppy

Optical Disk

Data is written and read using a laser. It can store up to 6 GB of data. It is of three types: CD-ROM – read-only, WORM – write once, read many times, and Erasable Disk – can be written and erased multiple times.

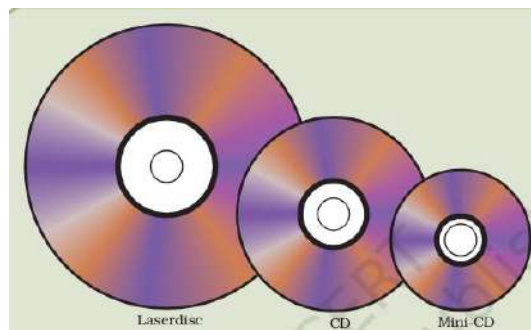

Fig. 4.5 Optical disks

Hard Disk

It is a magnetic disk with large storage capacity. It is faster and more reliable than a floppy disk and is the most commonly used storage device in computers.



Fig. 3.6 Hard Disk

Magnetic Tape

It is a long plastic strip on which data is recorded. Data has to be read sequentially. It is inexpensive and has large storage capacity but is slow. It is used for backup and long-term data storage.

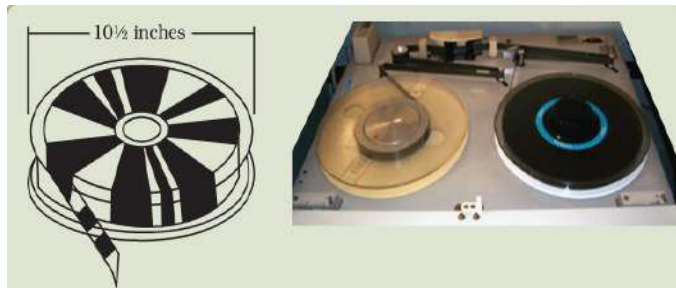

Fig. 4.7 Magnetic tape

Table: 3.3 Primary Storage vs. Secondary Storage

Primary Storage	Secondary Storage
It is the main memory as part of the CPU.	It is auxiliary memory which works under the control of CPU.
It is most expensive.	Relatively less expensive than primary memory.
Storage capacity is generally in MB or GB.	Storage Capacity is in GB and TB.
Retrieval and processing are very fast.	Retrieval and processing are comparatively slower.
Based on semiconductor technology	Based on magnetic or optical technology.

OVERVIEW OF HARD DISK DRIVE (HDD)

Hard Disk Drive (HDD) — The hard disk drive is the main and long-term storage device used in a computer. It is installed inside the computer case and is firmly fixed with screws. Its disks spin at a very high speed (about 5,400 to 15,000 RPM). Data is stored magnetically, so it re-

mains safe even when the power is turned off.

Types of Hard Disk Drives

- **Internal Hard Disk Drive:** This is present in every computer and serves as the main storage device. It allows quick and instant access to data.
- **External Hard Disk Drive:** This connects to the computer externally through a USB port. It is useful for storing and transferring large amounts of data and can be easily attached or removed from the computer.

Main Components of a Hard Disk Drive

- **Platter:** It has a magnetic coating where data is stored.
- **Spindle:** Rotates the platter at high speed.
- **Read/Write Head (R/W Head):** Reads data from and writes data to the platter.
- **Actuator Arm:** Moves the head to the correct position on the platter.

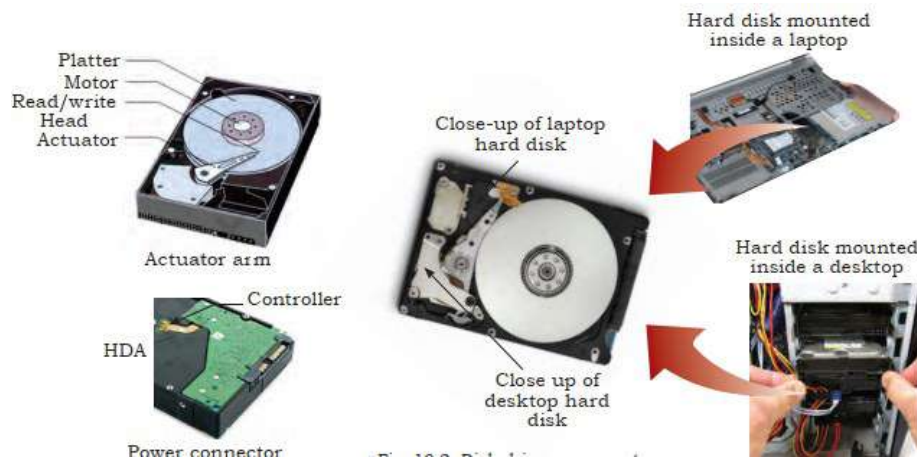

Fig. 4.8: Disk drive component

Working of Hard Disk

The data on the hard disk is stored in the magnetic domains on the magnetic material. It performs the recording function through its concentric circles or tracks.

When you initiate a command to store some data on the disk, the data flows into a cache. From there, the data is encoded using mathematically derived formulae. This is done to detect and correct the possible errors from the data. Further, free sectors on the disk are selected. Then the actuator moves the heads over those free sectors. These processes are followed just before the writing function.

When the writing time arrives, a pattern of electrical pulses passes through the writing element coil. This process produces a related pattern of magnetic fields.

The fields alter the magnetic orientations of bits and as a result, the bits represent the data. The reading process continues in a reverse direction. After consulting the locations of the

stored data, the actuator moves the head over those tracks, wherein the chosen data is located.

When the sectors receive the correct sensors, the magnetic fields from the bits induce resistivity changes. The changes locate the reading elements. The elements are further connected to electronic circuits. When the current flows from the electronic circuits, it helps in decoding the data stored in the disk.



Fig. 4.9 working of hard disk

Activity 1

Practical Activity 4.1 Installation of Internal HDD

Materials need

The process of installing an internal hard drive involves mounting it and connecting a couple of cables.

Drive cages, bays, and mounting options

Procedure

Internal 3.5-inch hard disk drives are mounted in a drive cage or drive bay. Placement and orientation of the cages or bays will vary from case to case. Drive cages/bays will most often be mounted perpendicular to the bottom of the chassis, while drives mounted in the cages usually sit parallel to the bottom of the case. The drive connectors are on the rear side of the hard disk drive.

Installation of internal HDD in a computer

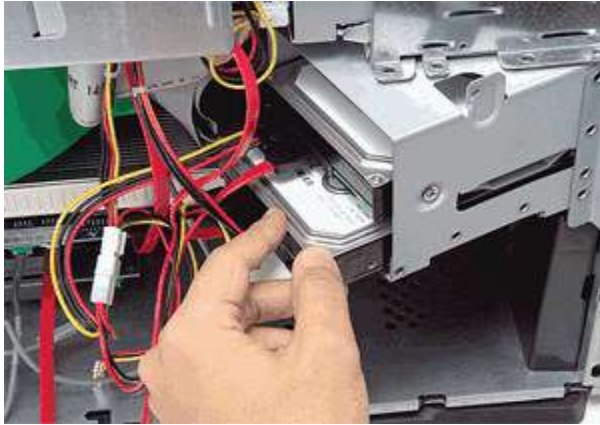

Fig. 4.10 Fit the Hard drive in case on **Fig. 4.11** Screwing the hard disk drive proper place

Step 1: Fit hard disk into a bay.

To fit a hard disk, identify a spare 3.5 inch drive bay. Four screws are required to secure the drive to a cage on the sides or bottom of the drive. Some drives have screw less fittings. Such hard drive come with tool-less brackets that make mounting hard drives easy. Slide the hard disk into a spare drive bay until the screw holes in the side of the drive line up with the holes in the drive bay. Then secure the disk with four screws, two on either side. Use magnet-tipped screw drivers. The screws are provided with the hard disk or case. Screw them tightly to prevent the drive.

When mounting drives in a system, try to leave as much space between them as possible to maximize airflow over the tops and bottoms. Positioning the drives directly in front of an intake fan also helps.

Step 2: Connect the hard drives with SATA.

Once the drive is mounted, connect it to system. The SATA interface hard drive uses SATA cables. One end of SATA cable is connected to the hard drive and other end to motherboard connector.

Step 3: Plug in SATA power.

Locate the correct connector from power supply unit (PSU) and plug it into the back of the hard disk. Be careful when plugging it in, as downward pressure can break the clip surrounding the power connector.

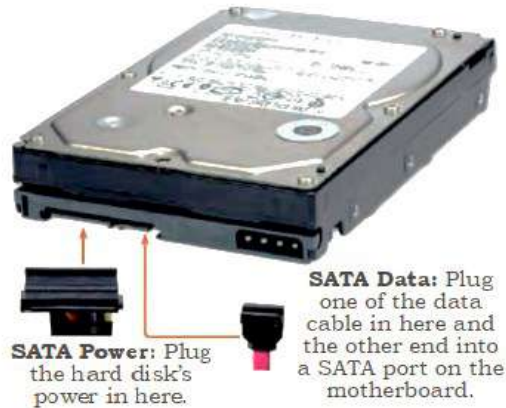

Fig. 4.12 SATA data and power cable port on hard drive

Step 4: Plug in SATA data cable.

Unlike IDE, SATA uses a simple and thin connector to carry data. The motherboard has several SATA cables. Take one of these and plug it gently into the rear of the hard disk. Be careful to plug it in, as downward pressure can break the connector and prevent the SATA cable plugging in.

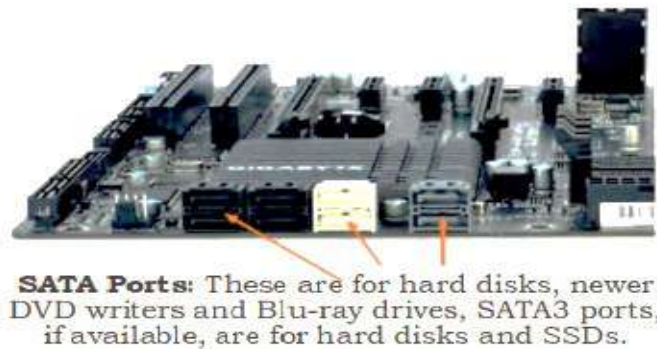

Fig. 4.13 Plug in SATA data cable

Step 5. Plug SATA data cable into motherboard.

Next, find a spare SATA port on motherboard. These are usually located at the bottom-right of the board and are numbered. The lowest number has the higher boot order in case of multiple disks. So plug the SATA cable into the lowest numbered port.



Fig. 4.14 Connecting SATA-data cable



Fig. 4.15 Plugging SATA data cable into the motherboard

Activity

Practical Activity 4.2 Installation of internal HDD in a laptop

Different laptops have different methods for accessing the storage drive.

Material required

Laptop, mini screwdriver, anti-static wrist strap, magnifying glass.

Procedure

There are several types of small screws that are used throughout the laptop. Place these in small envelopes and write the component name on the envelope. Be organized and keep track of all the screws. We have to figure out how to remove the back panel.

Step 1: Start the disassembly process by removing the battery. Turn the notebook upside down and remove all screws securing the bottom case. There are two screws (green circles) hidden under bottom.



Fig. 4.16 Remove battery and optical drive



Fig. 4.17 Back panel of laptop

Step 2: Remove three screws fixing the hard drive bracket to the case. Disconnect the hard drive cable from the motherboard.



Fig. 4.18 Open connector and release hard drive cable



Fig. 4.19 Remove old hard drive assembly

Step 3: Remove the old hard drive from the notebook and replace with new hard disk.

SOLID STATE DRIVES

These do not have any moving components. They use only electronics to store and retrieve

data. You can think of a SSD as a huge bank of random access memory (RAM). Most SSDs are non-volatile, meaning that they will not lose data when power is removed. The most common type of memory used with SSDs is flash based RAM, the same type of non-volatile RAM used in USB flash drives. SSD drives are lightning-fast when compared with mechanical hard drives. Additionally, they don't require motors to spin the platters and move the actuator, so they are lighter and draw less power.

Mobile devices such as tablets, commonly use SSDs, and many hobbyists replace laptop hard drives with SSDs. With the price of memory continuing to fall, SSD drives have become very affordable. For example, you can purchase a 128 GB SSD drive for about the same price as a 2 TB mechanical drive. Some people use a SSD drive for the operating system and applications, and use a mechanical drive for data. Most SSD drives use SATA and will install just like any other SATA drive. In addition to SSD drives and USB flash drives, several types of flash memory are used in digital cameras and recorders, including the following:

Compact flash (CF)

These are manufactured by SanDisk and are very popular. The outer dimensions are 43 x 36 mm. Type I CF devices are 3.3 mm thick, and Type II devices (known as CF2) are 5 mm thick. They can hold up to 128 GB of data.



Fig. 4.20 Compact flash

SD (Secure digital)

It supersedes Multi Media Card (MMC) which is the same size. The dimensions of SD are 24 x 32 mm. They can hold up to 2 GB of data.



Fig. 4.21 SD card

OPTICAL DISCS AND DRIVES

The modern PC comes with a DVD writer drive. The common types of discs which can be used in these drives include Blu-ray discs, different types of DVDs, and compact discs. An optical disc drive uses either electromagnetic waves or laser beams very close to the visible spectrum

of light to write or read the data on optical discs.

Apart from the general and exclusive applications in a computer, the optical disc drives are used as DVD players, CD players, and DVD recorders. They are most extensively used in computers for various purposes like archiving of data, reading software, recording discs, and to distribute the consumer media for exchange purpose.

Table 4.4 Capacity of different Discs and Drive

Types	Capacity	Comments
CD-ROM	700 MB	The standard size is 12 cm (4.7 inch).
Mini CD-ROM	194 MB	The size is 6 to 8 cm
DVD-ROM	4.7 GB	Dual sided DVD-ROM holds 4.7 GB on each side.
Dual layer DVD-ROM	8.5 GB	Dual sided dual-layer DVD-ROM holds 8.5 GB on each side.
Blu-ray single layer	25 GB	Blu-ray disk uses a blue laser, and CD and DVDs use a red laser.
Blu-ray double layer	50 GB	This is the common size used for movies. Triple layer holds 100 GB, and quad layer holds 128 GB.

Practical Activity 4.4 Installation of optical drive

Material required

Computer system, optical drive, screw driver

Procedure

Step 1. To install an optical drive, first check the position of the optical drive so that it aligns with the 5.25-inch drive bay.

Step 2. Insert the optical drive into the drive bay so that the optical drive screw holes align with the screw holes in the case (Figure 4.22).



Fig. 4.22 Insert optical drive

Step 3. Secure the optical drive to the case using the proper screws (Figure 4.23).



Fig. 4.23 Tighten screws of optical drive

Step 4. Connect the power cable coming from the SMPS to the power socket of optical drive.

Step 5. Connect SATA data cable from optical drive socket to the motherboard socket.



Fig. 4.24 Connect the SATA data cable

Step 6. Connect the SATA data cable to the optical drive as shown in Figure 3.28

Step 7. Connect the other end of the SATA data cable to the motherboard.

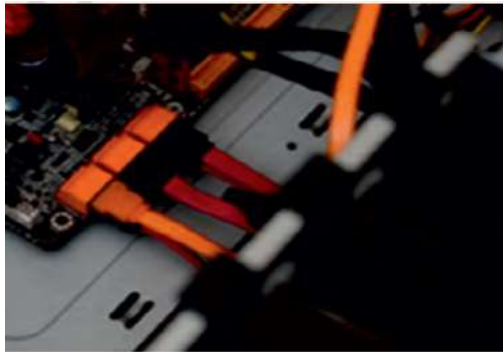

Fig. 4.25 Connect SATA data cable to the optical drive and in motherboard

Cloud Storage

Cloud storage services like Dropbox and Google Drive have revolutionized the way we store and manage our digital files. These platforms offer a convenient and efficient solution for storing documents, photos, videos, and more, allowing users to access their files from anywhere with an internet connection. With features like automatic syncing across devices, file sharing capabilities, and robust security measures, Dropbox and Google Drive have become essential tools for individuals, businesses, and educators alike. Whether you're

collaborating on a group project, backing up important documents, or accessing files on the go, these cloud storage services provide a seamless and reliable solution for managing your digital content.



Dropbox

Dropbox is a popular cloud storage service that allows you to store your files securely online and access them from any device with an internet connection. It's like having your own virtual filing cabinet where you can keep all your important documents, photos, and videos safe. With Dropbox, you can easily upload files from your computer or smartphone, and they'll be automatically synced across all your devices. This means you can start working on a project on your laptop at home, and then pick up right where you left off on your phone while you're on the go. Dropbox also makes it easy to share files with classmates, friends, or teachers by simply sending them a link. Plus, with features like file versioning and recovery, you can rest assured that your files are always protected. Whether you're working on homework assignments, collaborating on group projects, or storing personal files, Dropbox is a convenient and reliable solution for managing your digital content.



Google Drive

Google Drive is a powerful cloud storage platform provided by Google, offering a safe and convenient way to store, access, and share digital files. It's like having your own virtual storage locker accessible from any device with an internet connection. With Google Drive, you can upload documents, presentations, spreadsheets, and more, ensuring that your important files are always backed up and accessible whenever you need them. One of the most beneficial features of Google Drive is its collaboration tools, which allow multiple users to work on the same document simultaneously, making it ideal for group projects and assignments. Additionally, Google Drive integrates seamlessly with other Google Workspace apps like Docs, Sheets, and Slides, enabling you to create, edit, and share files directly from the cloud.

Whether you're working on school projects, organizing study materials, or collaborating with classmates, Google Drive provides a user-friendly and versatile solution for managing your digital content.



Summary

Storage devices save data for future use, such as hard disks and pen drives. Peripheral devices are those that enhance the functionality of the computer, such as printers and scanners. These devices make the computer's operation easier and more efficient.

Check Your Progress

A. Multiple choice questions (MCQs)

1. Which of the following is a primary memory storage device? (a) Floppy Disk (b) Hard Disk (c) Magnetic Tape (d) Cache Memory
2. What is the capacity unit commonly used to measure memory? (a) Kilobyte (KB) (b) Megahertz (MHz) (c) Gigabyte (GB) (d) Terabyte (TB)
3. Which type of memory is also known as volatile memory? (a) Cache Memory (b) Primary Memory (c) Secondary Memory (d) Magnetic Tape
4. Which memory is used for long-term storage of data? (a) Cache Memory (b) Primary Memory (c) Secondary Memory (d) Optical Disk
5. Which storage device is commonly used for storing large amounts of data for backup purposes? (a) Floppy Disk (b) Optical Disk (c) Hard Disk (d) Solid State Drive (SSD)
6. Which of the following is a component of a hard disk drive (HDD)? (a) Flash Memory (b) Platters (c) Optical Sensors (d) Laser Diodes
7. Which interface is commonly used for connecting hard disk drives (HDDs) to a computer system? (a) SCSI (b) USB (c) HDMI (d) SATA
8. Which type of storage device has no moving parts and is known for its fast performance? (a) Floppy Disk (b) Optical Disk (c) Solid State Drive (SSD) (d) Magnetic Tape
9. What is the function of an optical drive in a computer system? (a) Reading and writing data onto optical discs (b) Reading magnetic tape (c) Storing data in cache memory (d)

Retrieving data from floppy disks

10. Which type of digital data storage device uses laser technology to read and write data?
(a) Hard Disk (b) Magnetic Tape (c) Optical Disk (d) Solid State Drive (SSD)

B. True or False

1. Floppy disks are a primary memory storage device.
2. The capacity of memory is commonly measured in units such as kilobytes (KB), megabytes (MB), and gigabytes (GB).
3. Secondary memory is also known as volatile memory.
4. Magnetic tape is commonly used for short-term storage due to its fast access times.
5. Hard disks are non-volatile storage devices commonly used for long-term data storage.
6. The working of a hard disk involves data being stored magnetically on platters that spin at high speeds.
7. Solid State Drives (SSDs) use mechanical components to store data.
8. Optical discs, such as CDs and DVDs, use laser technology to read and write data.
9. SATA drives are a type of interface commonly used to connect hard disk drives (HDDs) to a computer system.
10. Disk drive performance refers to the speed and efficiency at which data can be read from and written to storage devices.

C. Fill in the blank questions

1. _____ is commonly measured in units such as kilobytes (KB), megabytes (MB), and gigabytes (GB).
2. _____ is non-volatile memory that retains data even when the computer is turned off, commonly used for long-term storage.
3. A _____ is a thin, flexible magnetic storage medium commonly used for storing and transferring data.
4. _____ use laser technology to read and write data onto discs, such as CDs and DVDs.
5. _____ store data magnetically on spinning platters and are commonly used for long-term data storage in computers.
6. _____ is a type of optical storage device commonly used for distributing software, movies, and music.
7. _____ involve data being stored magnetically on platters that spin at high speeds inside a sealed unit.
8. _____ refers to the speed and efficiency at which data can be read from and

written to storage devices.

9. _____ are interfaces used to connect hard disk drives (HDDs) to a computer system, providing fast data transfer rates.

D. Short Questions

1. What is the primary function of cache memory in a computer system?
2. Describe the difference between primary memory and secondary memory.
3. What are the two main types of memory in a computer system?
4. How does a hard disk store data?
5. Explain the working principle of a solid-state drive (SSD).

MODULE 2

INSTALLATION AND CONFIGURATION OF WINDOWS OPERATING SYSTEM

Module Overview

Windows operating system installation and configuration is a crucial process for setting up a computer. It begins with booting the system from installation media like a USB drive or DVD. The user selects the desired language, time, and keyboard preferences, then proceeds with the installation by choosing the partition where Windows will be installed. After the files are copied, the system will restart, and the initial setup will commence, prompting for user preferences such as account creation, network settings, and privacy options. Once configured, Windows will finalize the settings, installing necessary drivers and updates. Finally, the system is ready for use, with the option to further customize settings like display resolution, power management, and installing additional software as needed. Proper installation and configuration ensure the operating system runs smoothly, providing a stable environment for users to work efficiently.

Module Structure

Session 1: Basic of Operating System

Session 2: Install Windows operating system

Session 3: Configure Windows Operating System

Session 1. Basic of Operating System

CPU is the main processing unit of a computer. It processes the data based on the instructions received. Even for a simple calculation, it performs a series of instructions. Also, operating the several peripheral devices attached to, the computer requires executing certain instructions. The computer system has several resources such as a CPU, memory, storage devices, and network devices. All these resources are accessed by several users and several programs. The CPU manages all these resources. A computer also requires a basic user interface to interact with the user and provides consistent support to the processor, memory, and devices. An operating system (OS) is a software that satisfies all these needs of the user.

In this Chapter, we will discuss the components of operating system, the different types of operating systems and the functions of operating system. A brief description of some operating systems is also given.

Overview of operating System

A computer cannot perform any tasks on its own. In any computing process, both the hardware and software work together to accomplish a task. This applies to all the computing devices, including basic calculators, watches, mobile devices, and any other gadgets which use hardware components as well as integrated software components. Different files which are interrelated and accomplish a certain set of tasks make up the operating system. These files are system level files which do scheduling, interrupting, data transferring, managing the flow of data, and are a low-level software component of the computer itself. The standard definition of an operating system would be—an operating system is a set of program files which control the resources of the computer system and allows the communication of hardware components of a computer to the software components of the computer system.

Booting process of operating System

When you start the computer, it is observed that some initial text information is displayed on the screen. This is displayed by the firmware. The booting instructions are stored in ROM (read-only memory). Then the booting process starts. After booting, an operating system gets loaded in the main memory (RAM) of the computer. Let us understand the complete booting process.

- When you power on the computer, the CPU (central processing unit) activates the BIOS (basic input output system).
- The first program activated is POST (power on self-test). Using the CMOS (complementary metal oxide semiconductor) memory it checks all the hardware and confirms that they are functioning properly.
- After that it reads the MBR (master boot record) in boot drive in accordance with the firmware 'bootstrap loader' which is provided by the computer manufacturer.
- Then the computer loads in the operating system in boot drive to the RAM.

- Once this is performed, the operating system takes over the control of the computer and displays an user interface to the user.

Types of operating systems

Operating systems are normally preloaded on the computer that you purchase. But it is possible to upgrade or install the operating system on your computer. There are three most common types of operating systems—Microsoft Windows, Mac OS, and Linux. For mobile devices, such as smartphones and tablet computers, the commonly used operating systems are Apple iOS and Google Android.

Microsoft Windows:

It is a graphical user interface (GUI) based operating system. A typical desktop image of a computer system on which a Microsoft Windows 10 is installed is shown in Figure 4.13. In this GUI system, all the programs or commands of the operating system are available in the form of icons, buttons, and menus. Everything within the operating system is clearly displayed on the screen by making a combination of graphics and text. Whenever we want to execute any command or program, then the corresponding icon needs to be clicked.

There are various versions of Microsoft Windows OS available. Most recent version of Microsoft Windows OS is Windows 10, which was released in 2015. The earlier versions are Windows 8, released in 2010, and Windows 7, released in 2004. Microsoft Windows is one of the most popular operating systems.



Fig. 1.1 Microsoft Windows

Mac OS

It is an operating system that is created by Apple. It is a preloaded OS on Macintosh computer or Macs. A typical image of a Mac desktop is shown in Figure 1.2. Observe that this operating system also has a graphical user interface (GUI). But the GUI of Mac OS is different from that of Microsoft Windows. All the commands and programs available in Mac OS are displayed in the form of icons or buttons. By clicking appropriate buttons, we can execute that program.



Fig. 1.2 Mac OS

Linux

It is a family of open source operating systems. It means that it can be modified and distributed by anyone around the world. Earlier OS that we have discussed such as Windows and Mac OS are proprietary software. It means that they can be modified only by the company that owns it. Whenever you want to use proprietary software on your computer system, you need to purchase it by paying a cost so that you can get a user license. Linux is a freeware, meaning that you need not to pay any cost and you can use it on your computer system.

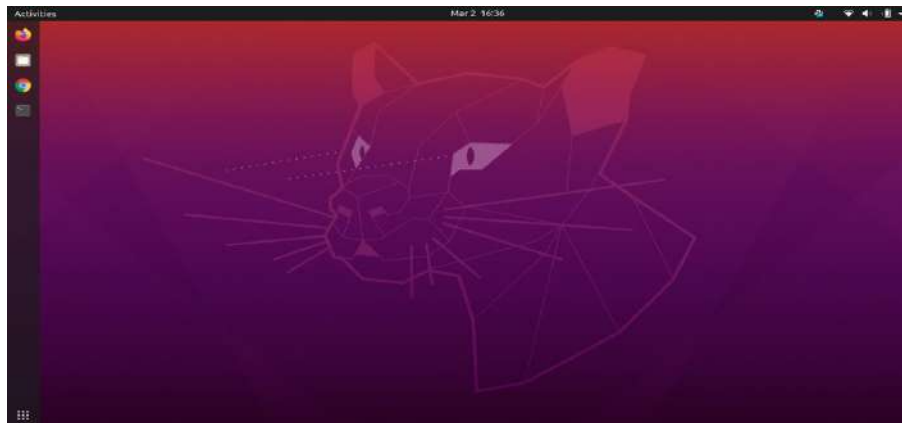

Fig. 1.3 Linux

A typical desktop image that runs Linux is shown in Figure 1.3. Observe that Linux is also available in the form of GUI. Every program in the Linux OS is displayed in the form of an icon, button, or graphics. By clicking on the icon or button, we can execute that program. There are many distributors of Linux, for example Ubuntu, Linux Mint, Fedora, Suse, Red Hat, and so on.

Classification of OS

Operating systems can be classified based on the following:

A. Classification based on Processing Method

Multi-programming OS: In this, two or more programs are executed simultaneously by a

single processor. It is used in a multi-user environment.

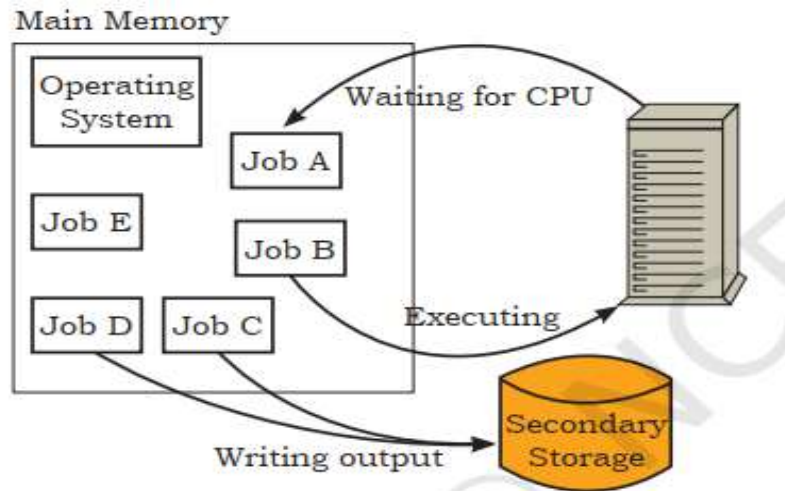

Fig. 1.4 Multi-programming with three programs

Multitasking OS: It is capable of running several tasks or programs at the same time. Most of the present operating systems like Microsoft Windows, Linux, and Mac OS are multitasking operating systems.

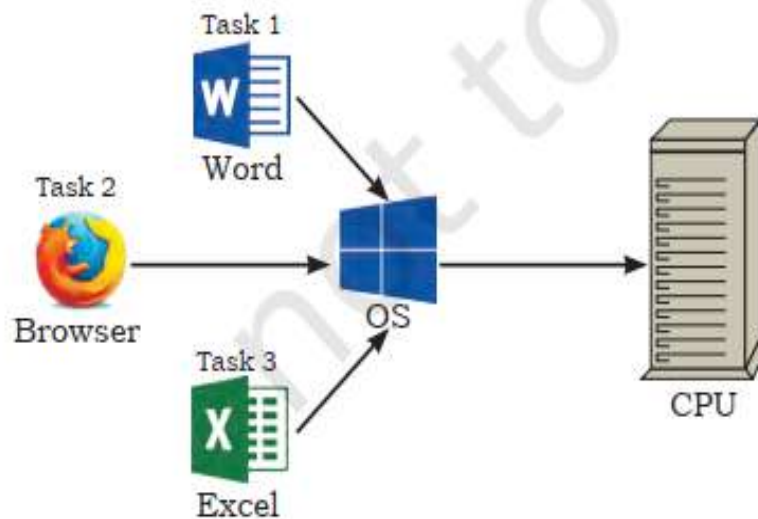

Fig. 1.5 Multitasking with three programs

Multiprocessing OS: It supports running a program in more than one CPU. Two or more processors (CPU) are used to control the different activities or execution of many program instructions simultaneously. Servers are designed to support multiple processors. UNIX is an example of multiprocessing OS.

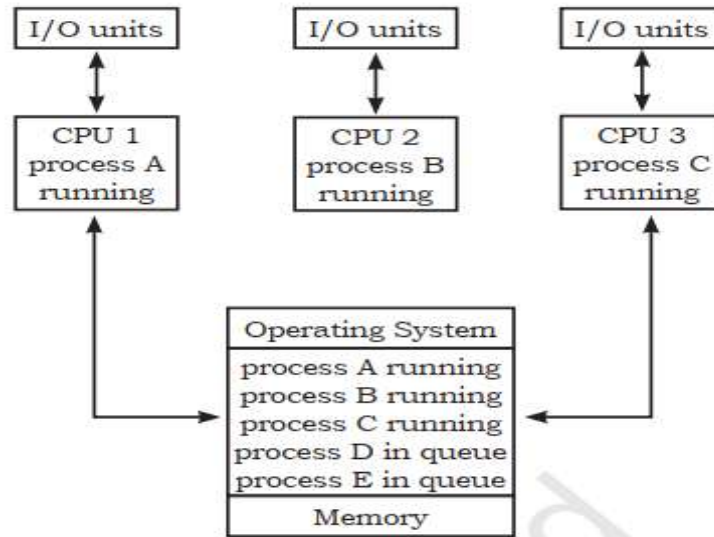

Fig. 1.6 Multiprocessing OS

Time-sharing system: In this, the processor is shared among many users. The CPU switches so rapidly from one user to another, that every user gets the impression of getting the services of CPU for all the time.

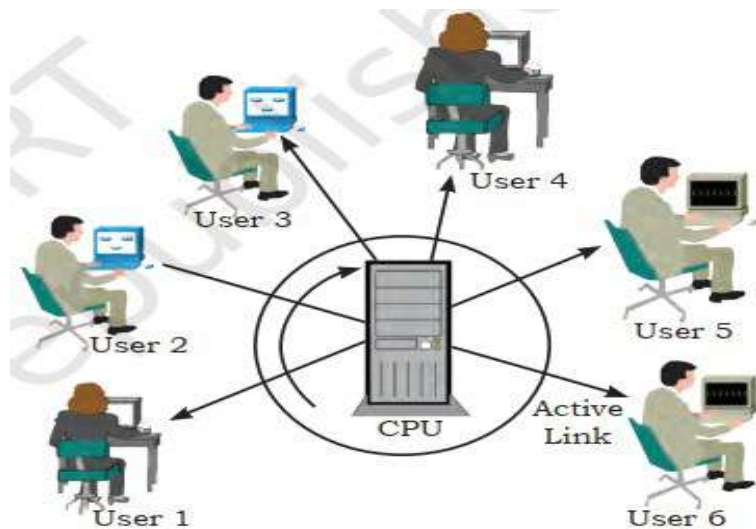

Fig. 1.7 Time sharing system

Multithreading OS: This has the ability to divide the process into sub-processes known as threads and execute them concurrently. Threads are individual processes that execute simultaneously in multi-tasking OS.

Batch processing OS: In this, similar jobs are grouped together for processing. It consists of programs, data, and system commands. The time taken between job submission and job completion is very high. It is suitable for programs with large computation time where user involvement is not necessary. Examples are payroll, forecasting, and statistical analysis.

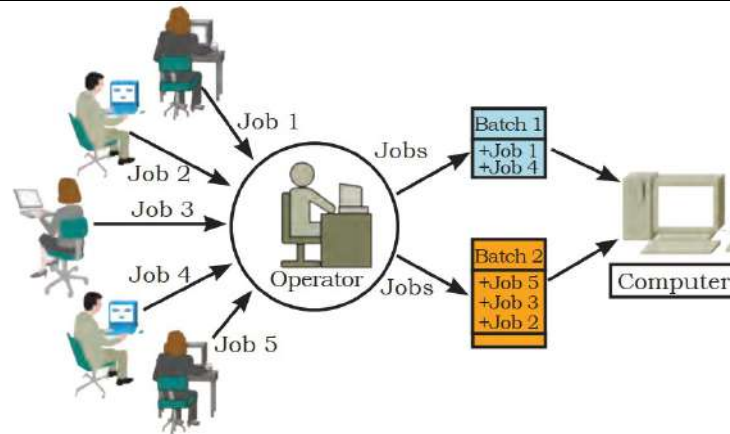

Fig. 1.8 Batch processing

Online processing operating system: In this, transactions are processed immediately and output is provided to the user. Most of the present systems use online processing. Bank transactions are an example of online processing system.

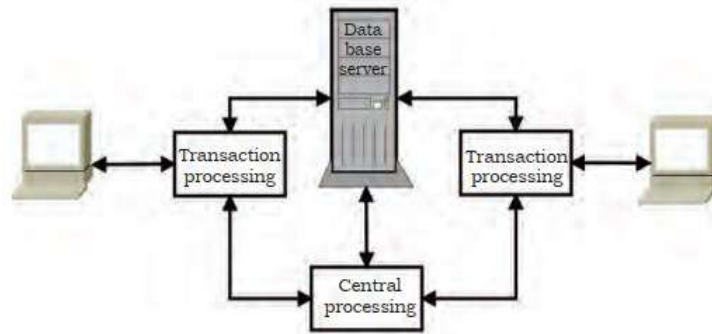

Fig. 1.9 Online processing

Real-time OS: This method receives data, processes it, and returns results quickly to affect the functioning of the system at that time. It is an online processing system where the processing time is critical. Monitoring and controlling nuclear power stations, rocket launching systems, are examples of real time systems.

B. Classification of OS based on User Interface

As we have already learned, there are two types of user interface. One is command line interface (CLI) and other is graphical user interface (GUI). The operating system is also classified on the basis of user interface.

Classification of OS based on Mode of User:

Under this classification, the OS is classified as single user or multi-user.

Single user OS: The majority of small microcomputer-based systems have single user OS, which allows a single user to operate the machine in an interactive mode. It allows only one user program to use the system. MS-DOS, PC-DOS are single user operating system.



Fig. 1.10 Single user OS

Multi-user OS: A multi-user OS allows two or more users to run programs at the same time. The multi-user OS shares computer resources among these users, allowing each a small slice of the processor time. This concept is known as time sharing. Example of multi-user OS are UNIX, LINUX.

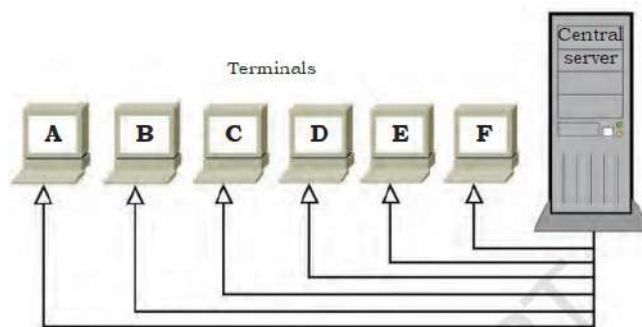

Fig. 1.11 Multi-user OS

Summary

The operating system is the main software of a computer that acts as an interface between the hardware and the user. Without it, the computer cannot function properly. It manages files, ensures security, and controls other important operations.

Check Your Progress

A. Multiple choice questions (MCQs)

1. What is an operating system? (a) A type of application software (b) Hardware used for processing data (c) Software that manages computer hardware and software resources (d) A programming language
2. Which of the following is not a function of an operating system? (a) Memory Management (b) Process Management (c) Internet Browsing (d) File System Management
3. Why do we need an operating system? A) To perform arithmetic operations B) To manage

hardware resources and provide a user interface C) To edit videos and images D) To design web pages

4. Which step comes first in the booting process of a computer? (a) OS Initialization (b) Loading the Bootstrap Loader (c) Power-On Self-Test (POST) (d) User Login
5. What type of operating system allows multiple users to interact with the computer at the same time? (a) Single-User OS (b) Multi-User OS (c) Batch Processing OS (d) Real-Time OS
6. Which of the following operating systems is designed for real-time applications? (a) Windows 10 (b) MacOS (c) Linux (d) Real-Time Operating System (RTOS)
7. Which type of user interface involves typing commands to interact with the operating system? (a) Graphical User Interface (GUI) (b) Command-Line Interface (CLI) (c) Touch Interface (d) Voice Interface
8. What is the role of device drivers in an operating system? (a) To manage user interfaces (b) To allocate memory (c) To enable communication between hardware and software (d) To manage files and directories

B. Fill in the blank questions

1. An _____ is a software that acts as an intermediary between the computer hardware and the user.
2. The primary purpose of an operating system is to manage _____ and software resources.
3. Without an _____, a computer would be useless to users and application software.
4. The _____ process involves powering on the computer and loading the operating system into memory.
5. The operating system's _____ management function involves allocating and deallocating memory space as needed by programs.
6. The _____ interface of an operating system provides a user-friendly way to interact with the computer, often through graphical elements like windows and icons.

C. True or False

1. An operating system is a type of hardware device.
2. The operating system acts as an intermediary between computer hardware and the user.
3. We do not need an operating system to run application software on a computer.
4. During the booting process, the operating system is loaded into memory after the Power-On Self-Test (POST).
5. One of the main tasks of an operating system is to manage memory allocation and deallocation.
6. A multi-user operating system allows multiple users to use the computer simultaneously.

D. Short Questions

1. How does an operating system manage computer hardware and software resources?
2. Why is an operating system necessary for a computer?
3. What are the main steps involved in the booting process of an operating system?
4. Name and briefly describe two key functions of an operating system.
5. List three different types of operating systems.

Session 2. Install Windows operating system

Windows 10 operating system is available for many devices such as phones, tablets, laptops, and desktop computers. It is also available in multiple editions and in both 32-bit and 64-bit versions. First, one needs to choose the appropriate edition and architecture of Windows to provide the necessary features, such as Secure Boot, Client Hyper-V, Cortana, and others. It is also important to verify the compatibility of existing hardware such as printers, scanners, and other peripherals with Windows 10.

In a new computer, a clean installation of Windows 10 is the preferred option. For a new computer, the user needs to select another appropriate installation option as per their requirements. This installation will resolve startup and shut down problems as well as memory usage and app issues. Also, you can get rid of viruses and other types of malware, fix system corruption, and improve battery life.

SYSTEM REQUIREMENT TO INSTALL WINDOWS OPERATING SYSTEM

To install the Windows operating system, the system requirements vary depending on the version. The table below provides a summary of the general system requirements for installing Windows 10 and Windows 11 (Table 2.1 Summary of System Requirements for Installing the Windows Operating System).

Requirement	Windows 11	Windows 10
Processor	1 GHz or faster with 2 or more cores on a 64-bit processor or SoC	1 GHz or faster processor or SoC
RAM	4 GB or more	1 GB for 32-bit or 2 GB for 64-bit
Storage	64 GB or more available	16 GB for 32-bit or 32 GB for 64-bit
System Firmware	UEFI, Secure Boot capable	No specific requirement
TPM	TPM version 2.0	No specific requirement
Graphics Card	DirectX 12 compatible with WDDM 2.0 driver	DirectX 9 or later with WDDM 1.0 driver
Display	High-definition (720p) display >9" with 8 bits per color channel	800 x 600 resolution
Internet Connection	Required for Windows 11 Home during setup	Not required for setup

It is also recommended to have an internet connection to download and install updates.

Types of Windows 10 installation – Clean installation and Upgrade installation, Windows 10 installation

When installing Windows 10, there are different types of installations you can choose from depending on your needs. These options include:

Clean Installation: A clean installation of Windows involves erasing all data on the target drive and installing a fresh copy of the operating system. This process can help improve performance, resolve software issues, and provide a fresh start with Windows. Here's a step-by-step guide to performing a clean installation of Windows:

1. Prepare for the Installation

- **Backup Your Data:** Before you begin, back up any important data and files as the clean installation will erase all data on the target drive.
- **Create Installation Media:** Download the Windows installation media from the official Microsoft website using the Media Creation Tool.
- Follow the tool's instructions to create a bootable USB drive or DVD.

2. Boot from Installation Media

- **Insert the Installation Media:** Insert the bootable USB drive or DVD into the computer.
- **Access Boot Options:** Restart your computer and access the boot menu. The key to access the boot menu varies by manufacturer, often F12, F10, Del, or Esc.
- **Select Boot Device:** In the boot menu, select the bootable USB drive or DVD to start the installation process.

3. Begin Windows Installation

- **Start Setup:** The installation process will begin automatically when you boot from the installation media.
- **Choose Language and Preferences:** Select your preferred language, time and currency format, and keyboard or input method.
- **Click "Install Now":** Click the "Install Now" button to begin the installation process.

4. Choose Installation Type

- **Custom Installation:** When prompted to choose the installation type, select "Custom: Install Windows only (advanced)".
- **Manage Partitions:** Select the drive where you want to install Windows. Delete any existing partitions to clear the drive and prepare it for the clean installation.
- Optionally, create new partitions if you want to organize your data differently.

5. Install Windows

- **Begin Installation:** Once you have chosen the drive, click "Next" to start the installation process.

- Windows will copy files, install features and updates, and complete the installation. This may take some time and your computer may restart multiple times.

6. Complete Setup

- **Follow On-Screen Instructions:** After installation is complete, follow the on-screen instructions to set up Windows.
- This includes creating a user account, connecting to a network, and choosing other settings.

7: Post-Installation

- **Install Updates:** Once Windows is set up, check for and install any available updates to ensure your system is up to date.
- **Install Drivers:** Install necessary drivers for your hardware devices to ensure everything works properly.
- **Restore Data:** Restore any backed-up data to your new installation if necessary.

Upgrade Installation:

An upgrade installation of Windows involves updating your existing version of Windows to a newer version while retaining your data, applications, and settings. This process is relatively straightforward and ensures that your files and preferences remain intact. Here's how to perform an upgrade installation of Windows:

1. Check Compatibility

- **Verify Hardware Compatibility:** Ensure your system meets the minimum hardware requirements for the new version of Windows. Check Microsoft's website for the most current system requirements.
- **Check Software Compatibility:** Some older applications may not be compatible with the new version of Windows. Verify compatibility with critical applications.
- **Check for Firmware Updates:** Make sure your BIOS/UEFI firmware and drivers are up to date.

2. Prepare for the Installation

- **Backup Important Data:** Although your data should remain intact during an upgrade, it's a good practice to backup important files as a precaution.
- **Create Windows Installation Media:** Download the Windows installation media from the official Microsoft website using the Media Creation Tool.
- Follow the tool's instructions to create a bootable USB drive or DVD.

3. Start the Installation

- **Run the Installation:** Insert the installation media (USB or DVD) into your computer and run the setup.exe file directly from the media, or mount the ISO file in File Explorer.

- Choose Language and Preferences: When the setup launches, select your preferred language, time and currency format, and keyboard or input method.
- Click "Install Now": Click "Install Now" to begin the installation process.

4. Choose the Upgrade Option

- Select Upgrade: When prompted to choose an installation type, select "Upgrade: Install Windows and keep files, settings, and applications." This option will upgrade your current version of Windows while retaining your existing data.

5. Proceed with the Installation

- Complete the Upgrade: Follow the on-screen prompts to proceed with the upgrade installation. Windows will copy files, install features, and update the system.
- The installation may take some time, and your computer may restart several times during the process.

6. Post-Installation

- Complete Windows Setup: After the upgrade, follow any on-screen instructions to complete the setup, such as signing in with your Microsoft account.
- Install Updates: Check for and install any Windows updates to ensure your system is up to date.
- Verify Applications: Test your applications and peripherals to make sure everything is working properly.
- Restore Backups: If you made backups, ensure your data and applications have been restored properly.

Configuring Correct Boot Order

Configuring the boot order on a Windows operating system involves adjusting the settings in your computer's BIOS or UEFI firmware to specify which devices your system should boot from first. This is essential when you want to boot from a specific device such as a USB drive, DVD, or a different hard drive. Follow these steps to configure the boot order:

1. Enter BIOS/UEFI Firmware

- Restart Your Computer: Restart your computer.
- Enter BIOS/UEFI: During the initial boot process, press the key to access your BIOS/UEFI settings. This key is often displayed on the screen during startup and varies by manufacturer (commonly F2, Del, F10, or F12).

2. Navigate to Boot Options

- Locate the Boot Menu: In the BIOS/UEFI settings, navigate to the boot or boot order menu. This section may also be labeled as "Boot Options" or something similar.

3. Configure the Boot Order

- Select the Boot Device Order: Look for a list of bootable devices such as hard drives,

USB drives, and optical drives.

- Change the Boot Priority: Adjust the order of the devices by moving the desired device (such as a USB drive or DVD drive) to the top of the list. This tells the system to attempt booting from that device first.
- Save Changes: Once you've set the boot order, save your changes. This is typically done by pressing a key such as F10, though this can vary by manufacturer. Follow the on-screen prompts if available.

4. Exit BIOS/UEFI and Boot from the Chosen Device

- Exit BIOS/UEFI: Exit the BIOS/UEFI settings, usually by selecting the "Save and Exit" option.
- Boot from the Device: Your computer will restart and boot from the device you prioritized in the boot order. If you chose a USB drive or DVD, the installation or other process will begin from that media.

Activity

Practical Activity 2.1: Demonstrate to configure boot order before installation of Windows.

In modern systems, you can adjust the boot order to prioritize a bootable USB drive and set its path on the BIOS settings page. The key to access the BIOS settings may vary depending on the manufacturer and system model. A quick way to find out the correct key is to search online for your system's BIOS key.

Step1. Access the BIOS settings on your system. To do this, turn off your PC, then press and hold a specific key (such as "F2") while turning on your computer. This key varies by manufacturer and will allow you to enter the BIOS settings when the system starts up. For newer systems, make sure to connect the bootable USB drive before you access the BIOS settings.

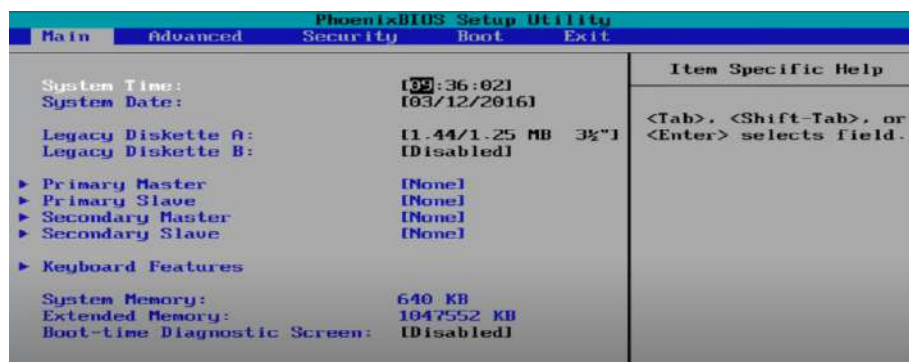

Fig. 2.1

Step 2. Go to the “Boot” options to change the boot order.

To go through the options in the toolbar, press the **left or right arrow keys**.

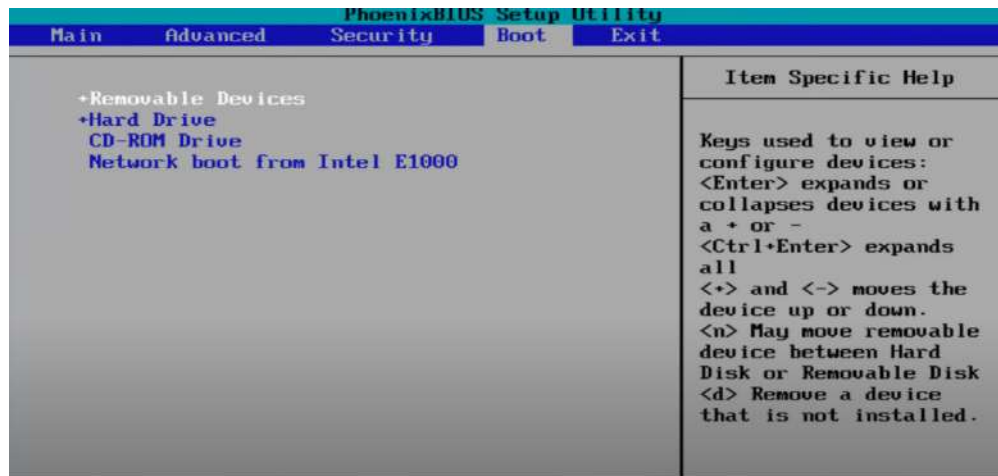

Fig. 2.2

Step 3. Set up a new boot order.

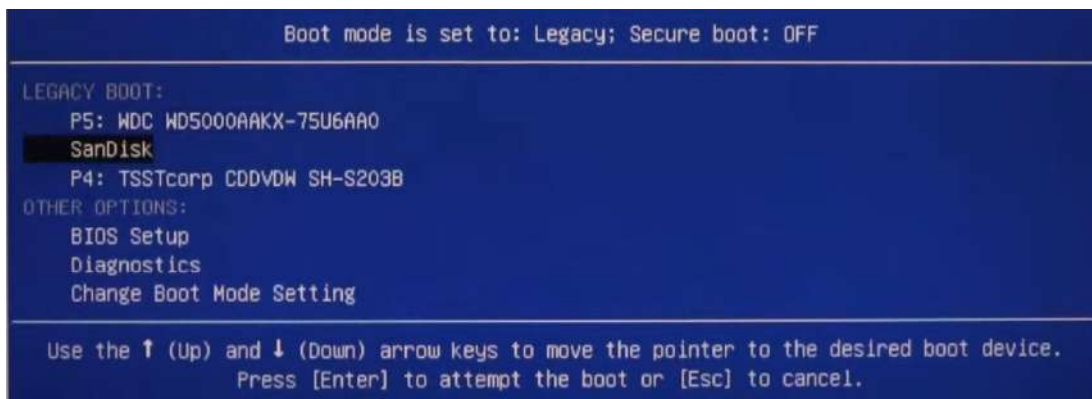

Fig. 2.3

Step 4. If you have any external drives with a different boot order, it will pop up here. In the drive, select the boot order, then go back to the boot option and select that as Boot Option #2. It will be as shown below.

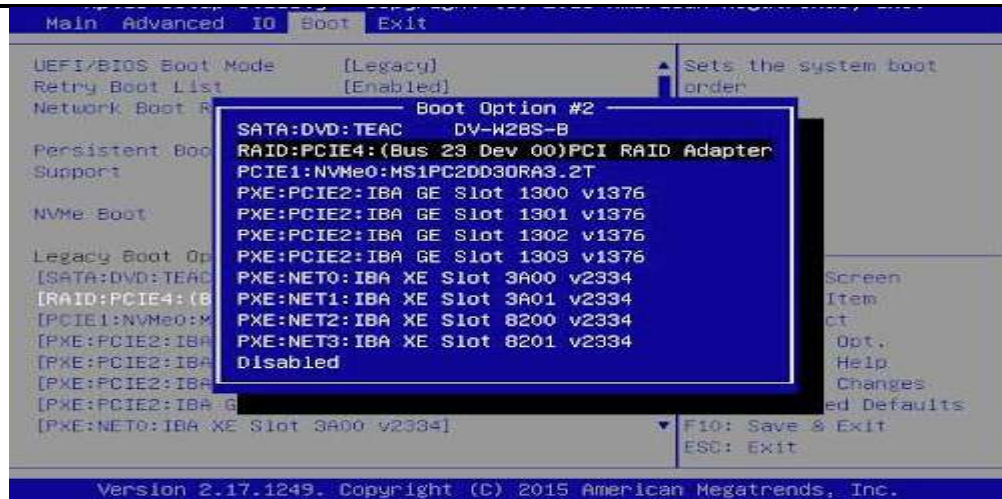

Fig. 2.4

Step 5. Save and Exit the BIOS Information

After selecting the boot option, save the changes and exit the BIOS system. For that, navigate to the Save & Exit option.

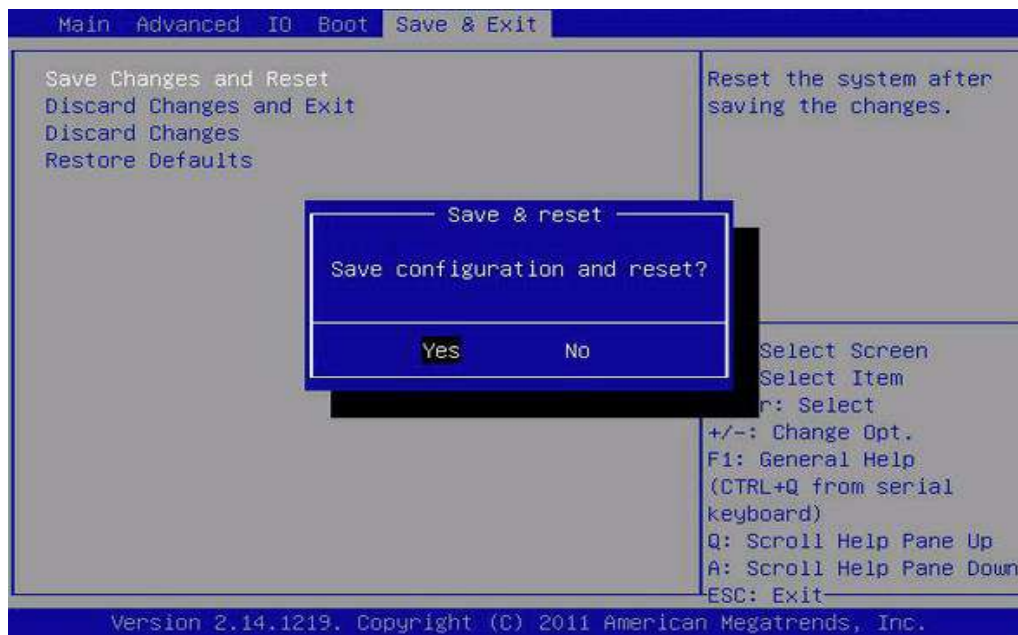

Fig. 2.5

Disk Management

Disk Management is a Windows utility that allows you to perform advanced storage operations. Here are some tasks you can accomplish with Disk Management:

1. Set up a new drive: Initialize new disks to prepare them for use.
2. Extend a volume: Increase the size of a volume by adding unallocated space on the same

drive.

3. Shrink a partition: Reduce the size of a partition, which can then allow you to extend a neighbouring partition.
4. Change or assign a drive letter: Modify existing drive letters or assign new ones to drives.

Disk Management shows whether a disk is online (accessible) or offline. In Windows, newly discovered disks are automatically brought online with read and write access by default. In Windows Server, newly discovered disks are also brought online with read and write access unless they are on a shared bus (such as SCSI, iSCSI, Serial Attached SCSI, or Fibre Channel). Disks on a shared bus remain offline upon initial detection. If a disk is offline, you must bring it online before you can initialize it or create volumes on it. To bring a disk online or take it offline, follow these steps:

Open Disk Management:

Search for "Computer Management" in the taskbar search box and select Storage > Disk Management.

Right-click the Disk:

Right-click the disk you want to manage and choose the appropriate action from the context menu.

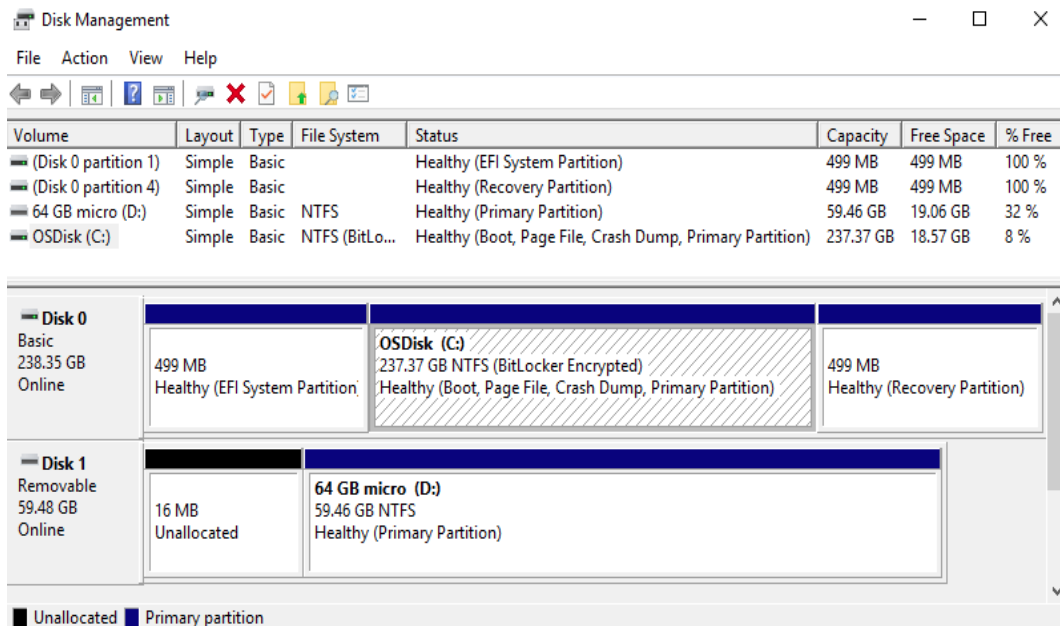

Fig. 2.6

5.4 Performing a Clean Installation of Windows 10

Perform a Clean Install on an Empty Hard Disk/SSD or Reinstall by Booting from Install Media (DVD or USB Thumb Drive) Follow the steps below for clean installation of Windows 10:

Step 1. Once your computer is set to boot from the DVD, you should see this option. If you

are installing from a retail Windows 10 USB thumb drive, you will be asked to select either 32- or 64-bit Windows 10.

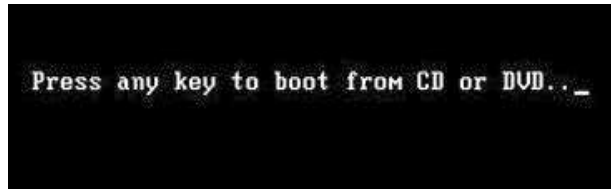

Fig. 2.7 Boot from CD and DVD

Step 2. The Windows logo will appear on screen, this might be here for a while, as long as you see the animating dots, everything should be ok.

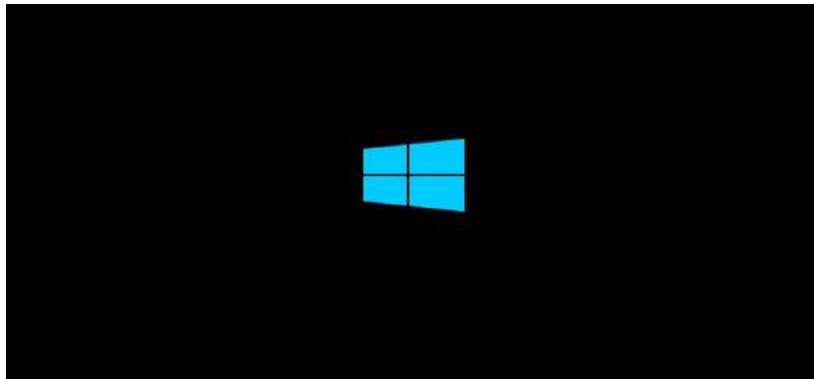

Fig. 2.8 Installing Windows

Step 3. Select your Language, Time and Keyboard method then click Next.

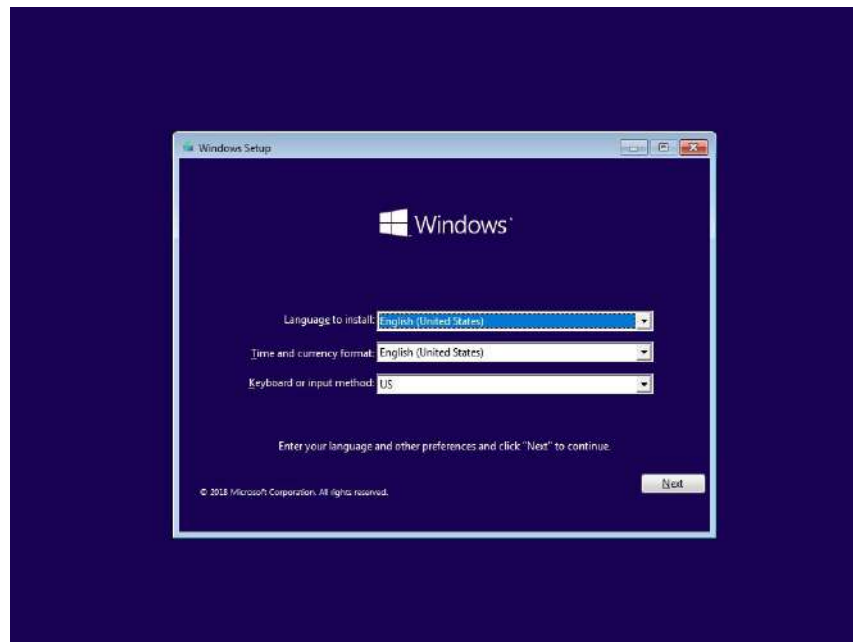

Fig. 2.9 Select language, time, and currency

Step 4. Click **Install now**.



Fig. 2.10 Installation window and input

Step 5. Windows 10 setup will prompt you for a product key during installation a couple times. If you originally upgraded from Windows 7 or Windows 8/8.1 click the option 'I don't have a key' and 'Do this later'. If you have a Windows 10 product key, you can proceed to enter it.



Fig. 2.11 Installing Windows

Step 6. Setup will also prompt you to select the edition you have a license for - **Home** or **Pro**. Please make sure you **choose the right edition**. If you choose the wrong edition, your only option will be to perform a clean install again.

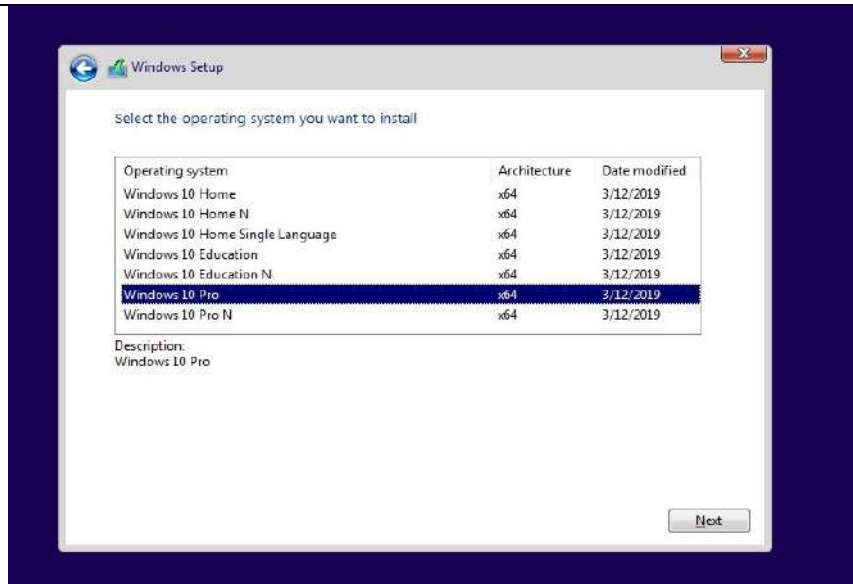

Fig. 2.12 Select Window 10 edition

Step 7. Wait while setup prepares to copy files.

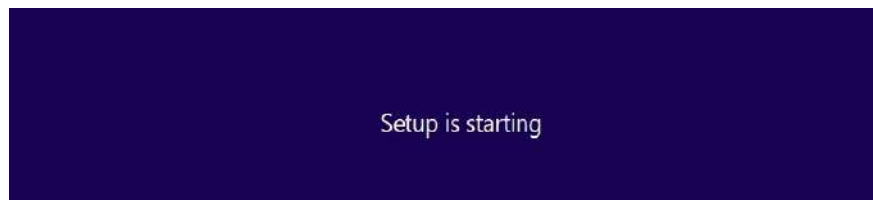

Fig. 2.13 Setup prepare

Step 8. Accept the license terms then click **Next**.



Fig. 2.14 License terms

Step 9. Click Custom: Install Windows only (advanced).

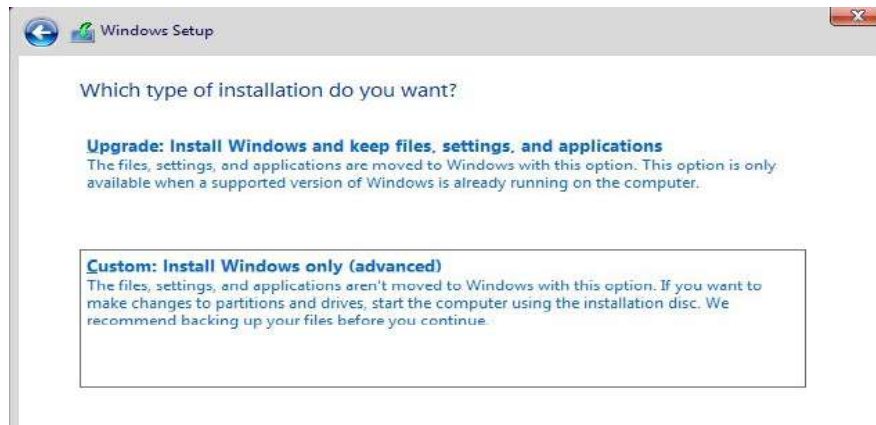

Fig. 2.15 Selecting installation setup window

Step 5. Select the drive then click **New**.

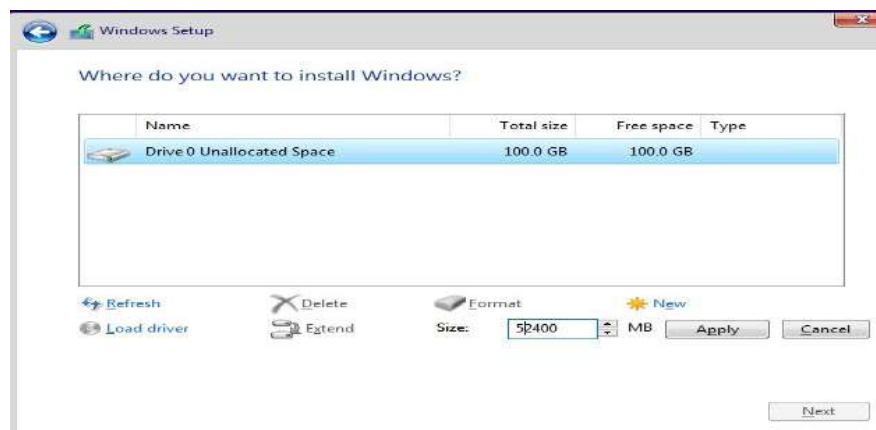

Fig. 2.16 Partition window

Step 11. Select the unallocated drive listed, click **New**, click **Apply** then **OK**.

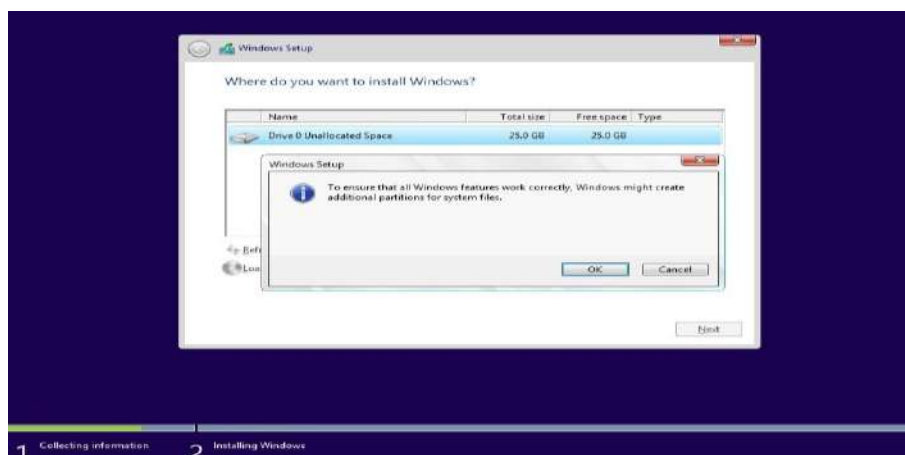

Fig. 2.17 Drive 0 unallocated space

Step 12. This will split the drive into multiple partitions, select the **Primary** partition then click **Next**.

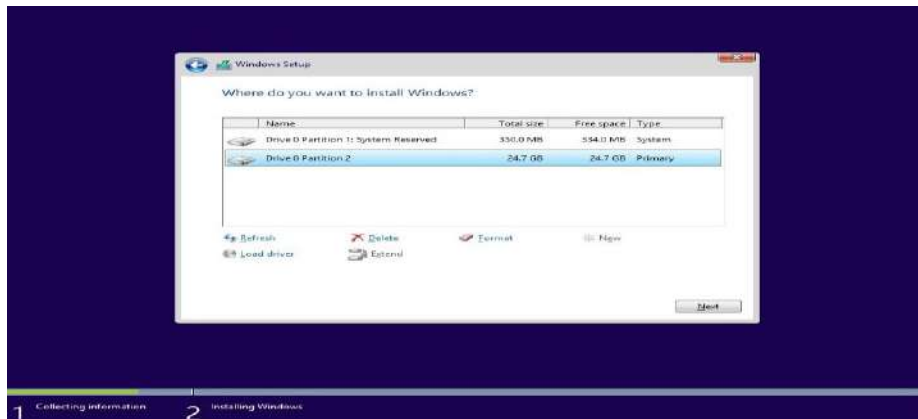

Fig. 2.18 Drive 0 allocated space

Step 13. Wait while Windows installs.

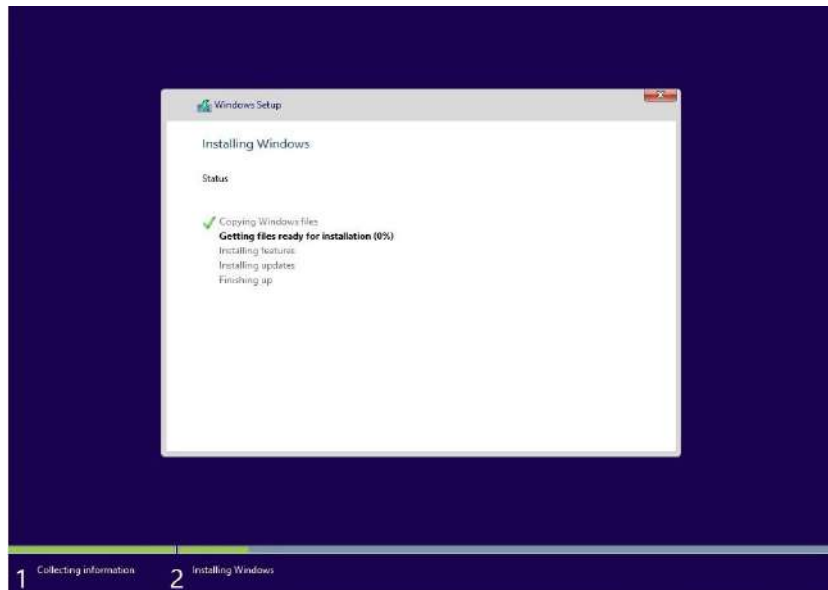

Fig. 2.19 Copy setup files Installing Windows

Step 14. When this phase of setup is complete, Windows will automatically restart then reboot into setup again.

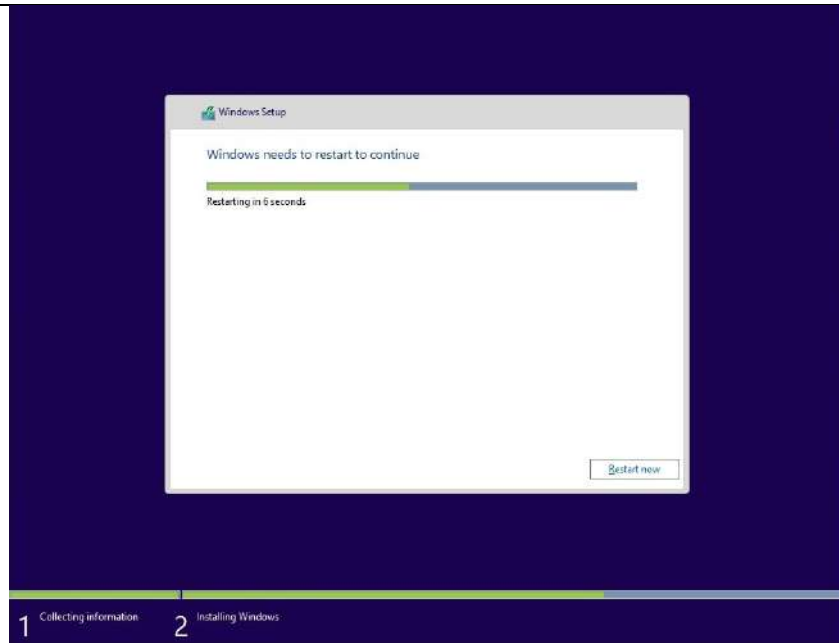

Fig. 2.20 Setup is complete

Step 15. Windows is detecting and installing your hardware. After this is complete, Windows will restart one last time.

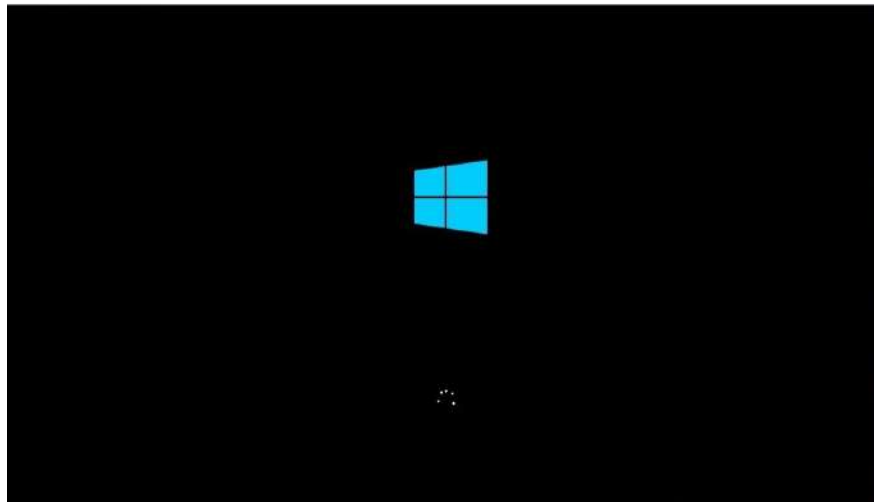

Fig. 2.21 Window setup is completed

Step 16. After complete installation, the initial, window will appear on the computer screen as shown in Fig.



Fig. 2.22 Home window of windows 10

Post Installation Tasks

After installation of Windows 10, you need to perform certain post installation tasks.

- (i) Check whether Windows is activated or not. To confirm that you're running an activated copy of Windows 10, open 'Settings'. For this, press the windows key and type settings in the textbox. The Windows setting will be displayed as shown in Figure 5.23.



Fig. 2.23 Windows setting

- (ii) Click on 'Update & Security' as shown in Figure 2.24.

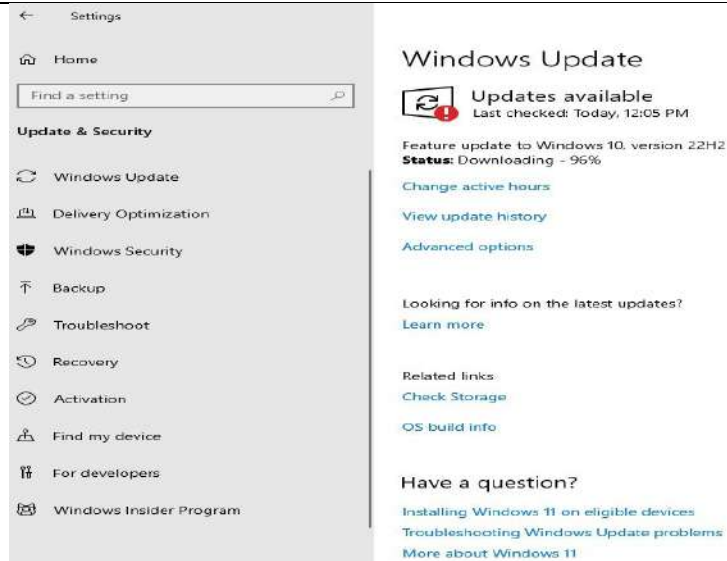

Fig. 2.24 Selecting update and security

(iii) Click on 'Activation' as shown in Figure 2.25.

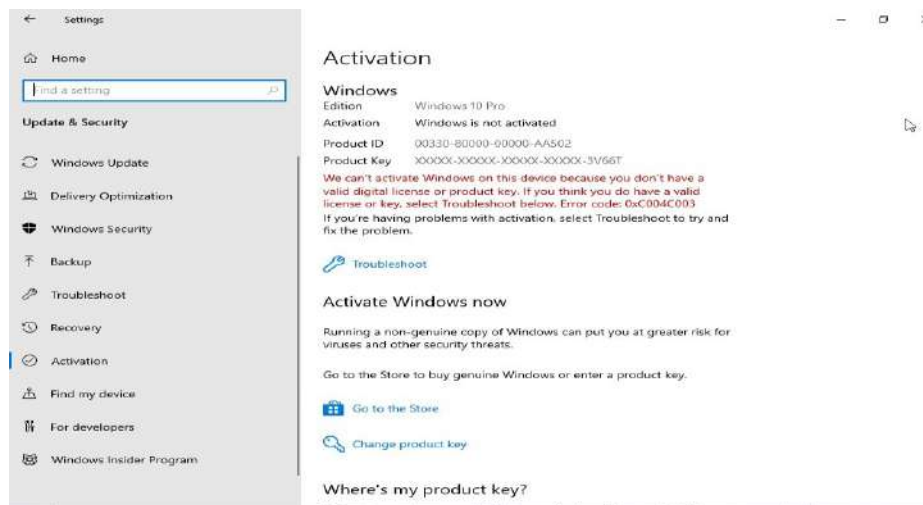

Fig. 2.25 Selecting activation

(iv) Under the 'Activation' head, Windows edition and activation status is displayed as 'Windows is activated with a digital license' as shown in Figure 2.26. This confirms that your Windows 10 is activated. Instead of this if it shows the message 'Windows is not activated', then you need to activate the Window by entering the product key.

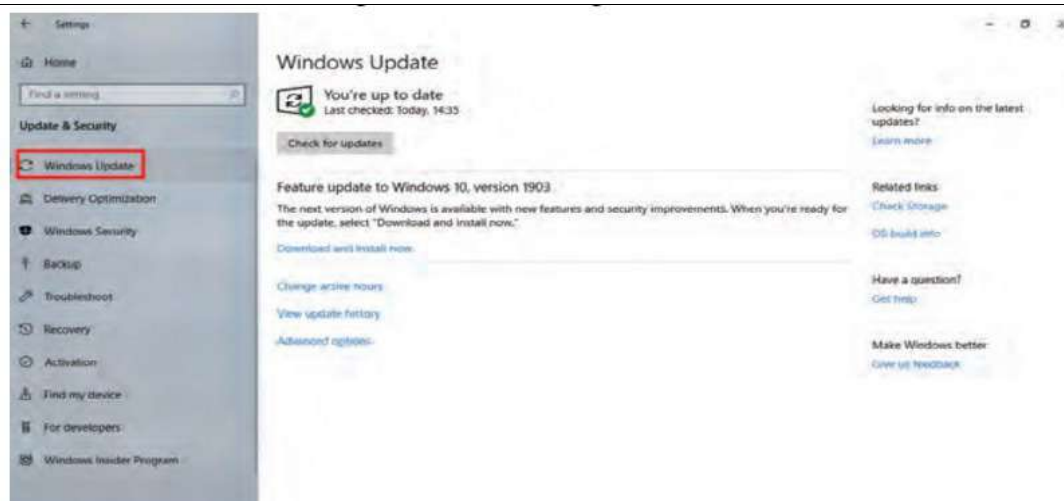

Fig. 2.26 Selecting activation

- (v) To install the latest updates:
- (i) Open 'Settings'.
 - (ii) Click on 'Update & Security'.
 - (iii) Click on 'Windows Update'.

Summary

To install Windows, a bootable device is required. During the boot process, installation steps must be followed—such as selecting the disk, setting time and language preferences, and creating a user account. After installation, the computer becomes ready to use with the new operating system.

Check Your Progress

A. Multiple choice questions (MCQs)

1. When was the first version of the Windows Operating System released? (a) 1980 (b) 1985 (c) 1990 (d) 1995
2. Which Windows version introduced the Start menu and taskbar? (a) Windows 1.0 (b) Windows 3.1 (c) Windows 95 (d) Windows XP
3. What is the minimum required RAM for installing the 64-bit version of Windows 10? (a) 1 GB (b) 2 GB (c) 4 GB (d) 8 GB
4. Which tool is used to create a bootable USB drive for Windows 10 installation? (a) Device Manager (b) Media Creation Tool (c) Task Manager (d) Windows Update
5. What is the primary difference between an upgrade installation and a clean installation of Windows 10? (a) Upgrade installation retains files and settings, while clean installation erases all data. (b) Upgrade installation erases all data, while clean installation retains

files and settings. (c) Both methods retain all data. (d) Both methods erase all data.

6. Which setting must be configured to boot from a USB drive for Windows 10 installation? (a) Control Panel (b) Disk Management (c) BIOS/UEFI (d) Task Manager
7. How do you access Disk Management in Windows 10? (a) Right-click the Start button and select "Disk Management" (b) Open Task Manager and go to "Disk Management" (c) Use Control Panel to open "Disk Management" (d) Press Ctrl + Alt + Delete and select "Disk Management"
8. What task is NOT performed after installing Windows 10? (a) Install updates (b) Configure user accounts (c) Install drivers (d) Uninstall Windows 10
9. Which version of Windows OS is known for significant performance improvements over Windows Vista? (a) Windows XP (b) Windows 7 (c) Windows 8 (d) Windows 10

B. Fill in the blank questions

1. The first version of the Windows Operating System was released in the year _____.
2. To install the 64-bit version of Windows 10, a minimum of _____ GB of RAM is required.
3. The _____ tool is used to create a bootable USB drive for Windows 10 installation.
4. During a clean installation of Windows 10, all existing data is _____.
5. To configure the correct boot order for Windows 10 installation, you need to access the _____ settings.
6. In Windows 10, Disk Management can be accessed by right-clicking on the _____ button and selecting "Disk Management."
7. One of the main features introduced in Windows 10 is the _____ assistant.

C. True or False

1. Windows XP was released before Windows 95.
2. The minimum required RAM for installing the 64-bit version of Windows 10 is 4 GB.
3. A clean installation of Windows 10 retains all files and settings from the previous version.
4. To install Windows 10 from a USB drive, you must configure the boot order in BIOS/UEFI settings.
5. Disk Management in Windows 10 can be accessed by right-clicking the Start button.
6. Windows 8 introduced the Start screen instead of the Start menu.
7. The first version of the Windows Operating System was released in 1990.

D. Short Questions

1. Describe the evolution of the Windows Operating System from its inception to the present day. Include major versions and their significant features.

2. What were the major features introduced in Windows 95, and why were they significant?
3. Explain the system requirements for installing the 64-bit version of Windows 10. Why are these requirements important?
4. Outline the steps involved in installing Windows 10 from a bootable USB drive. What preparations must be made before beginning the installation?
5. Compare and contrast an upgrade installation and a clean installation of Windows 10. What are the advantages and disadvantages of each method?
6. Explain how to configure the BIOS/UEFI settings to boot from a USB drive. Why is this step necessary for installing Windows 10?
7. What are the functionalities of the Disk Management tool in Windows 10? Describe how to access and use this tool.
8. Detail the process of performing a clean installation of Windows 10. What are the key steps and considerations?

Session 3. Configure Windows Operating System

Windows Desktop

An operating system or GUI (graphical user interface), the desktop is the primary place to display and organize icons on a screen. The Microsoft Windows desktop was introduced with Microsoft Windows 95 and is included with every version of Windows since then. The Figure 3.1 below is an example of the Microsoft Windows 10 desktop.

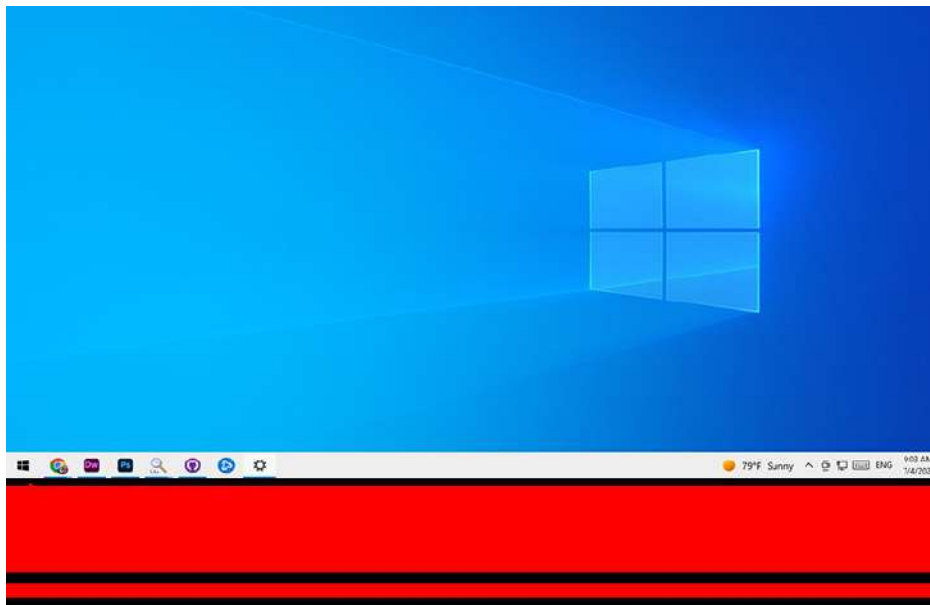

Fig. 3.1 Microsoft Windows 10 desktop

In this example, there are no icons on the desktop, and the wallpaper is a blue screen with the Windows 10 logo. Also, the taskbar is at the bottom of the desktop and contains the Start, taskbar icons, Windows Notification Area, and the time and date.

Common icons on the desktop include those for My Computer, Recycle Bin, your Internet browser (e.g., Internet Explorer), and My Documents. On the Windows desktop, you can find the Windows Start menu through the Start on the taskbar, and the Windows Notification Area.

If some or all of these icons are missing on the desktop, you can change which icons are displayed. Follow the steps to show or hide these icons.

Missing icons in Windows 10

Step 1. Right-click an empty area on the desktop and select Personalize.

Step 2. In the window that opens, click Themes in the left navigation menu.

Step 3. Scroll down and click Desktop icon settings under Related Settings.

Step 4. In the Desktop Icon Settings window, select the check boxes next to the icons you want to display.

Step 5. Click Apply, and then OK.

or

Step 1. Click Start or press the Windows key.

Step 2. Type themes and related settings and press Enter.

Step 3. Scroll down and click Desktop icon settings under Related Settings.

Step 4. In the Desktop Icon Settings window, select the check boxes next to the icons you want to display.

Step 5. Click Apply, and then OK.

The date and time are also shown on the desktop in the notification area on the taskbar. If the date and time are incorrect, you can change the date and time from the desktop.

Setting date and time in the operating system

Note: Windows 10 and Windows 11 automatically adjust the date and time for you and only let you adjust the time if you disable the automated feature. If the wrong date and time are set, or you must change the time or time zone, follow the steps below.

Step 1. Right-click or tap the date and time in the Windows Notification Area in the bottom-right corner of the screen.

Step 2. Select Adjust date/time from the pop-up menu.

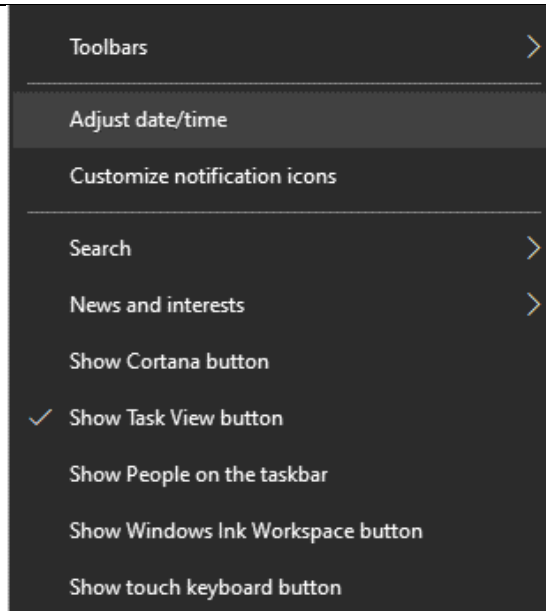



Fig. 3.2 Windows notification area

Step 3. If you want the time set automatically, ensure the toggle switch for the Set time automatically option is in the On  position and your Time zone is correct.

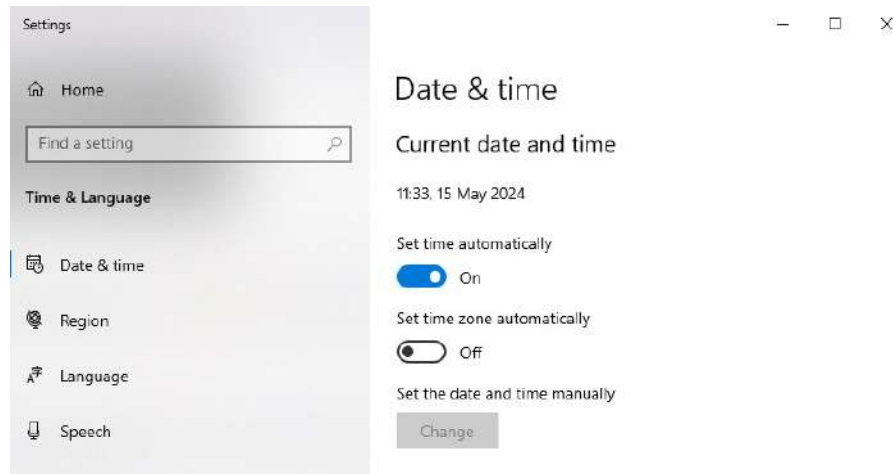



Fig. 3.3 Setting Date & Time

Step 4. To manually adjust the time, click the toggle switch under Set time automatically option so that it's in the Off  position, then click the Change button.

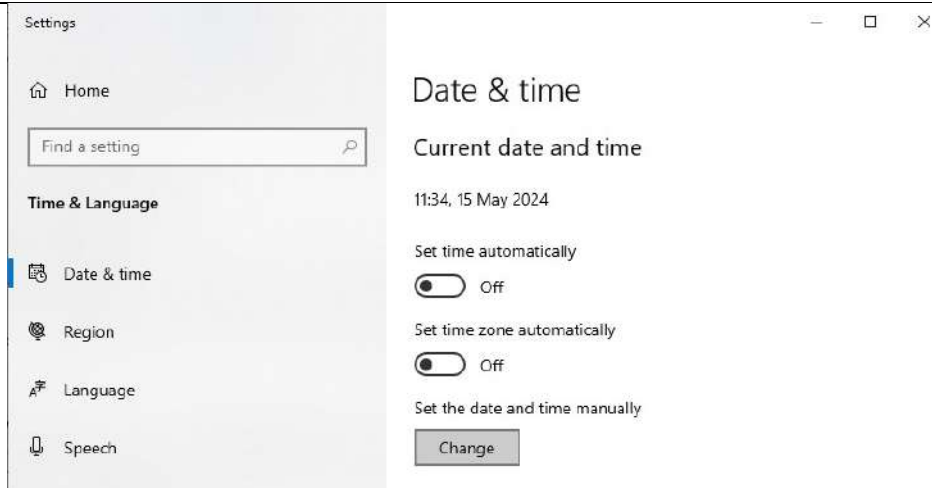

Fig. 3.4 Set time automatically option current date & time

Step 5. In the window, adjust the date or time as desired, and click the Change button.

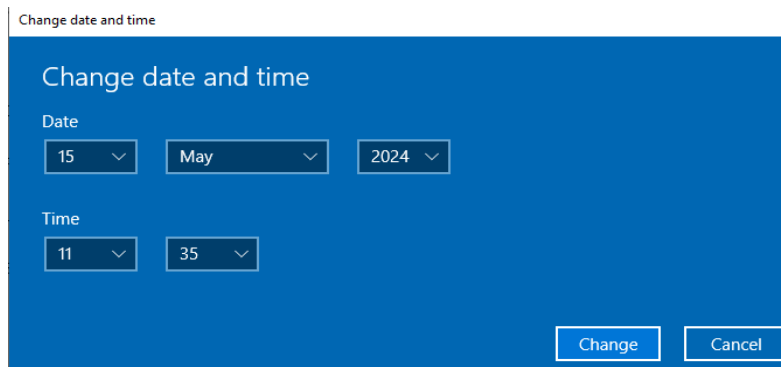

Fig. 3.5 Adjust the date or time

Windows taskbar

The Windows taskbar is one of the core components of the operating system's GUI (Graphical User Interface) and has many features and uses. The taskbar is located at the bottom (by default) of the Microsoft Windows desktop. In addition to showing the running programs, the taskbar also displays the Start button and Start menu, pinned programs, the time, notification area and, in some versions, Quick Launch. The following Figure shows various iterations of the taskbar in the different versions of Windows.



Fig. 3.6 Window Taskbar

If you don't see the taskbar, it's usually because it is hidden or was dragged down too far. Follow these steps to resolve this issue.

How to toggle auto-hide for the taskbar

Step 1. Press the **Windows key**, type **Taskbar settings**, and press **Enter**.

Step 2. In the Taskbar window, look for the "automatically hide" option.

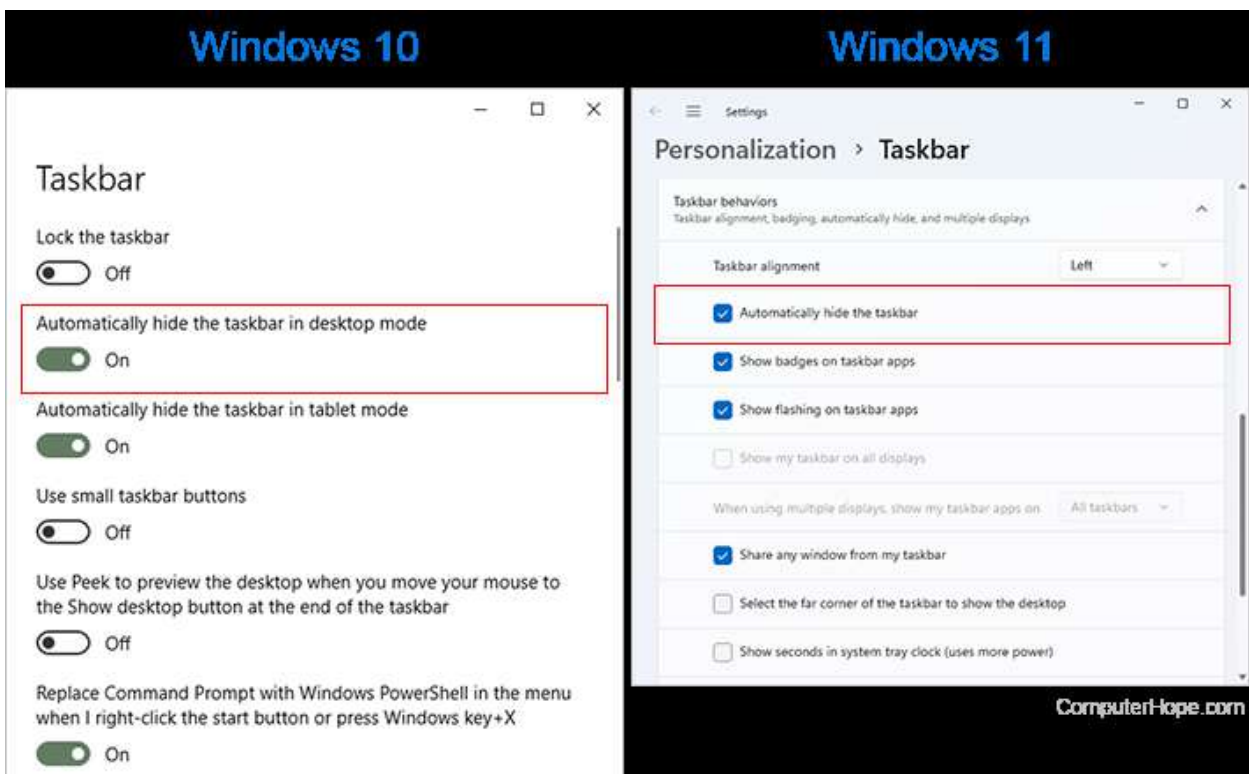

Step 3. Click the toggle switch or uncheck the box next to the Automatically hide the taskbar entry to restore its default functionality (showing at all times).

Load to Safe Mode to fix the taskbar

If you still cannot get the taskbar to show, reboot the computer in Safe Mode. Then, restart the computer again to restore the taskbar.

Restore Windows to an earlier point or version

If, after trying the three options above, the taskbar is still not showing, your computer may have corrupt system files that are preventing the taskbar from showing. To fix this issue, try restoring Windows to an earlier version or previous restore point.

How to do a System Restore in Windows 11

Step 1. Press the **Windows key**, type **restore point**, and press **Enter**.

Step 2. At the top of the System Properties window that opens, on the **System Protection** tab, click the **System Restore** button.

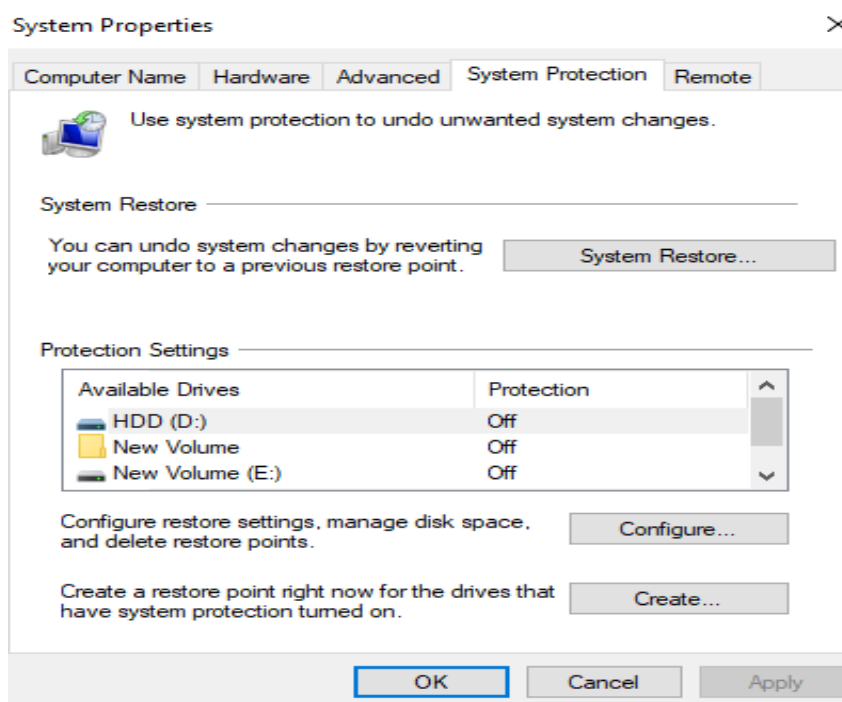

Step 3. In the System Restore window that opens, the date of the most recent change or update to your computer is recommended, by default. To restore Windows to that date, click the **Next >** button.

Step 4. Alternatively, if you know the date your problem started, select the **Choose a different restore point** option and click the **Next >** button. Select a restore point and click **Next >** again.

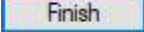
Step 5. Click the  button to start the restore process.

My taskbar moved to the left, top, or right side of the screen

Sometimes, users mistakenly move the taskbar to the left, top, or right side by accidentally dragging it to one of these locations. To return the taskbar to the default position (the bottom of the screen), follow the steps below.

Step 1. Move the mouse cursor to where the time is displayed on the taskbar. In later versions of Windows, like Windows 10, move your cursor to an empty area of the taskbar.

Step 2. Press and hold the left mouse button, then move the cursor to the area on the screen where you want to move the taskbar.

Step 3. Once you see the taskbar move to its new location, release the left mouse button.

Resize the taskbar

To resize the taskbar, move your mouse cursor to the top edge of the taskbar. When the mouse is in the correct position, the cursor should change to a double-headed arrow pointing up and down. Press and hold the mouse button and move the taskbar up or down to increase or decrease its size.

File Explorer

Alternatively called Windows Explorer or Explorer, File Explorer is a file browser found in every version of Microsoft Windows since Windows 95. It is used to navigate and manage the drives, folders, and files on your computer. The Figure below shows File Explorer in Windows 10.

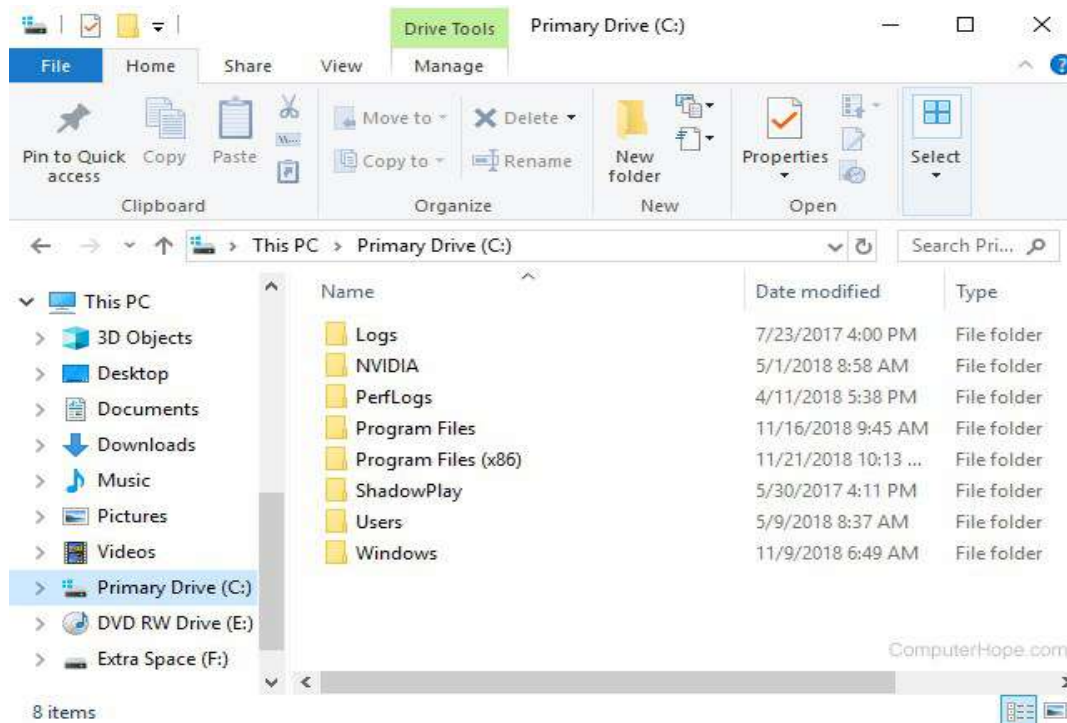

How to open Windows Explorer

There are several ways to open a new Explorer window, which vary slightly depending on which version of Windows you are running.

In all versions of Windows

Press Windows key+E (hold down the Windows key and press E).

Click Start, select Run (or press Windows key+R), type explorer or explorer.exe, and press Enter.

If displayed on the Windows desktop, click or double-click the My Computer icon (named Computer in Windows Vista & 7, and This PC in Windows 8 & 10).

File Explorer sections

Below is a diagram of the different sections of File Explorer, with brief explanations of each.

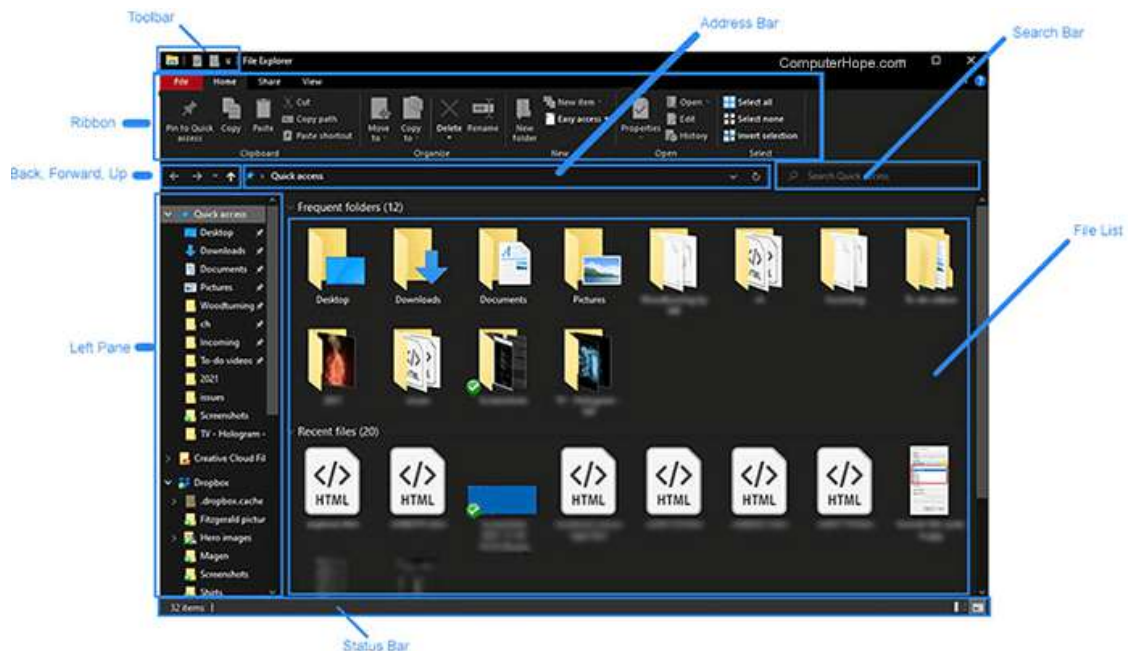

Toolbar - A quick menu for navigating around File Explorer. You can customize what is shown here by clicking Customize Quick Access Toolbar.

Ribbon - Each section of the Ribbon, Home, Share, and View, has multiple options for accessing features and executing actions in File Explorer. For example, Home has standard features like copy and paste, and adding a new folder.

Back, Forward, Up - Pressing Back takes you to the last folder you were viewing. Pressing Forward, moves to the next folder. Pressing Up takes you to the drive or folder location of the object you're viewing, or to the Desktop folder, depending on your location in File Explorer.

Left Pane - Shows all the main devices and drives connected to your computer. It also shows the network your computer is connected to, if any.

Status Bar - Shows the number of files or folders in each location and each file or folder's size.

Address Bar - Shows your current location in File Explorer. You can also use this to type a drive or file you want to access.

Search Bar - Allows you to search for a drive, folder, or file name.

File List - Displays the current list of files in the selected drive or folder.

Region and language support in Windows 10

Windows 10 supports 111 languages of 190 countries and regions. If you want to change the language, you can download any of the additional languages for Windows 10. The following activity demonstrates how to add an input language to your PC.

Activities

Practical Activity 3.1 Configure Windows 10 for language support

Step 1. Open 'Settings' > 'Time and Language' > 'Region & Language'.

Step 2. Under 'Languages' select 'Add a Language'.

Step 3. Select the language you want to use from the list, as shown in Figure 1.

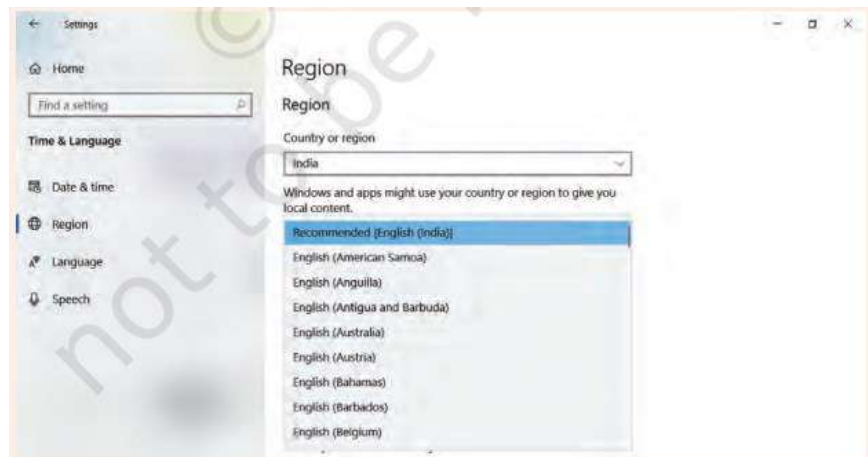

Fig. 3.7 Time and language window

Step 4. Windows 10 searches 'Windows Update' for the desired language and then installs it on your computer.

Step 5. Click the 'Check for updates' button as shown in Figure 3.8

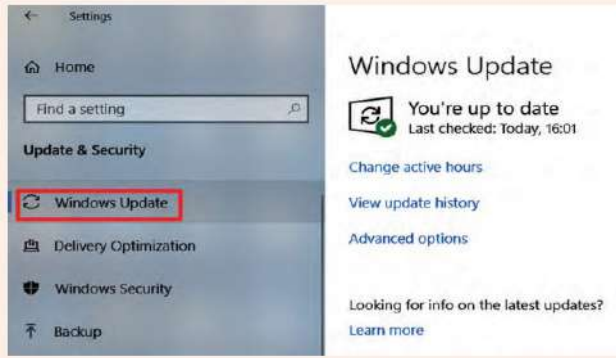

Fig. 3.8 Selecting 'Windows update'

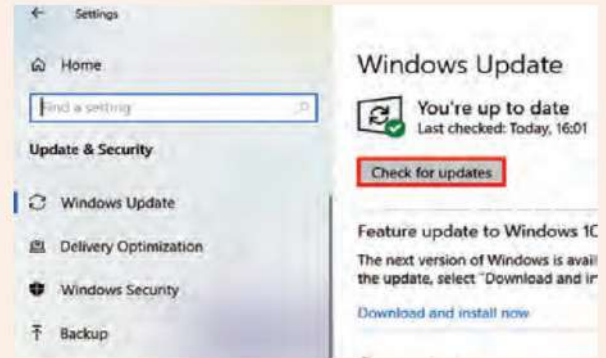

Fig. 3.9 Check for updates

Device driver

Step 3. To confirm that all the device drivers have been installed correctly, invoke the 'Device Manager' through the Windows key as shown in Figure 3.10.

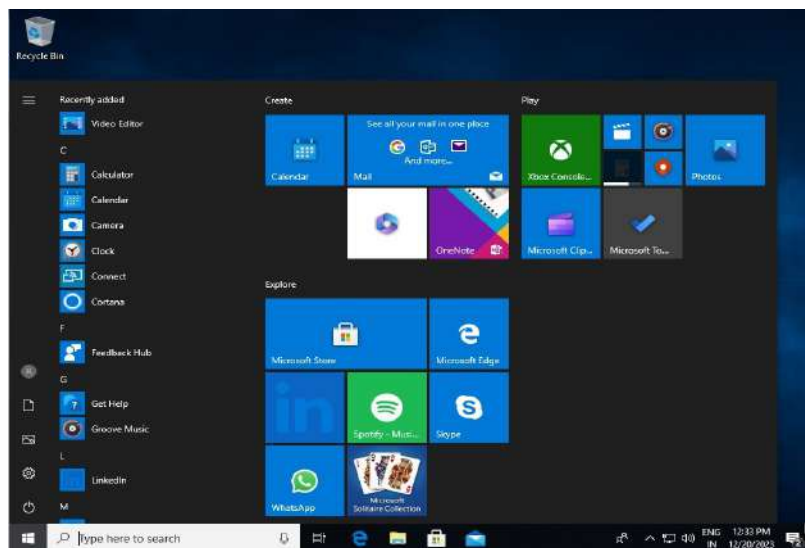

Fig. 3.10 Invoke device manager through the Windows key

Step 7. Search for 'Device Manager' as shown in Figure 3.11. The device manager window will open.

Step 8. Observe that the drivers for all the devices are installed. In the case of any missing driver, download the latest available driver for the device manufacturer and install it.

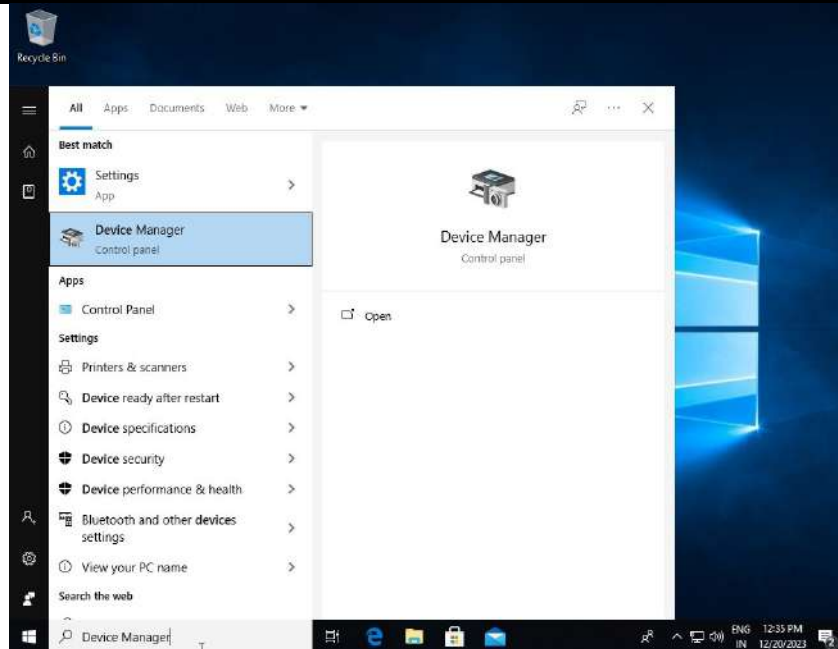

Fig. 3.11 Search device manage

Windows 10 automatically updates the device driver. If you do not want to update the device driver, then you can turn off the automatic installation of device driver. The following activity will demonstrate how to turn on or off the automatic installation of device driver.

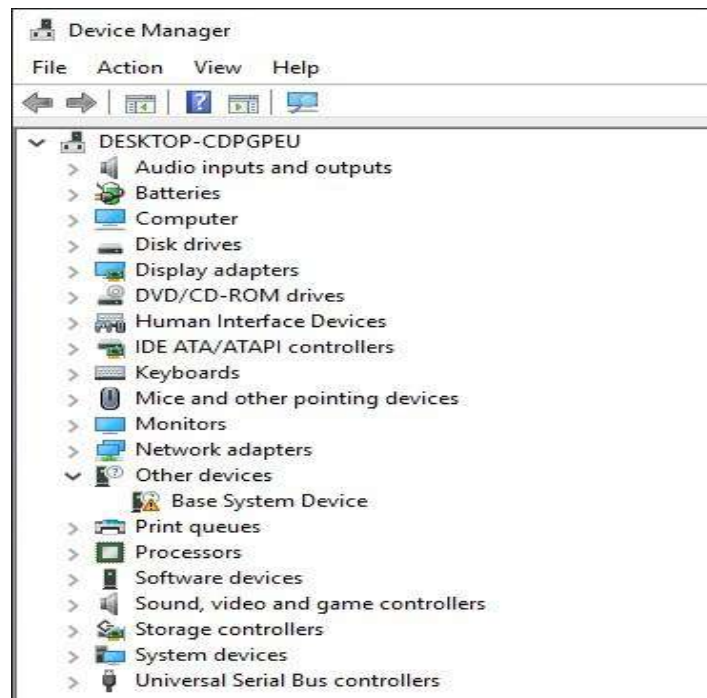

Fig. 3.12 Device manager window

Practical Activity 3.2 Turning off automatic installation of device driver

Step 1. Open 'Control Panel', click on 'Devices and Printers'.

Step 2. The icons of the various devices will be displayed. Right-click on the 'Desktop' icon. The Desktop icon shows your computer name. Then select and click on the 'Device installation settings', as shown in Figure 3.13.

Step 3. 'Device installation settings' dialog box will appear as shown in Figure 3.13. By default, the 'Yes' option is selected. Choose the option 'No' and then click on the 'Save Changes' button.



Fig. 3.13 Disabling the automatic device driver software installation

Step 4. The changes will be saved which will turn off the automatic updates.

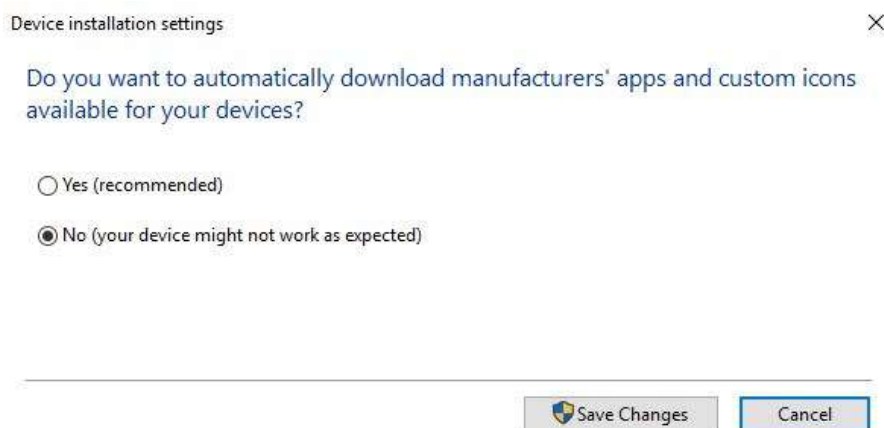

Fig. 3.14 Device installation setting dialog box

Static IP address configuration in Windows 10

To access Internet on your computer, you need to configure the network settings in Windows. Internet connection availability and access in Windows is indicated via an icon residing on the taskbar. If you see a yellow triangle exclamation mark on the network icon, it means that, it has limited network connectivity.



Fig. 5.22: Selecting network access option

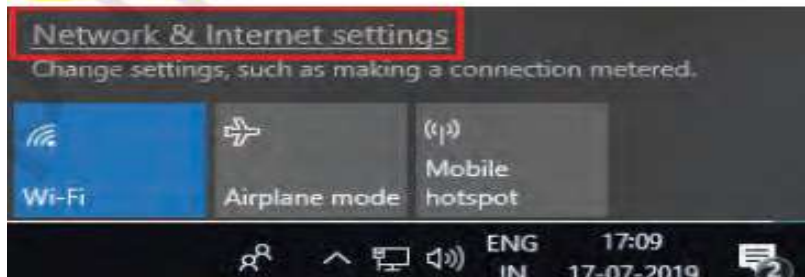

Fig. 3.15 Open 'Network & Internet setting'

Step 5. Right click the network icon in the taskbar and select 'Open Network & Internet settings' as shown in Figure 3.16.



Fig. 3.16 Open ethernet setting



Fig. 3.17 Change adapter options

Step 6. In the 'Open Network & Internet Setting' window, click on 'Ethernet' as shown in Figure 3.18, to see the settings of your connection. You can change the related settings.

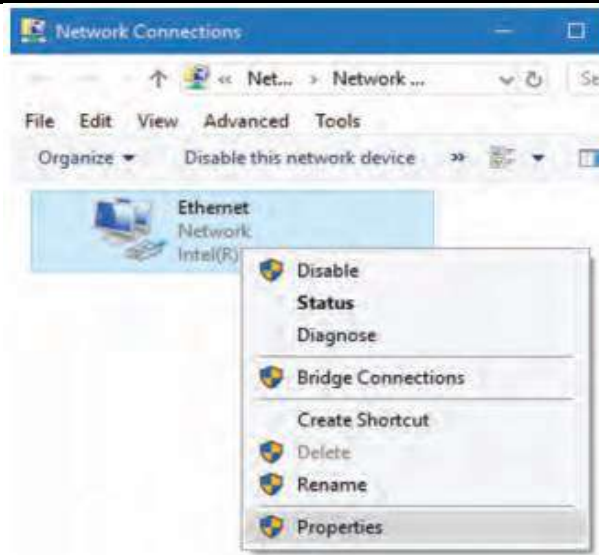

Fig. 3.18: Ethernet properties

Step 7. Right click your active network adapter and choose 'Properties', as shown in Figure 3.18.

Step 8. Under 'This connection is using the following items', double click on 'Internet Protocol Version 4 (TCP/ IPv4)', as shown in Figure 3.19 to change the current IP address and the DNS server.

Step 9. Select 'Use the following IP address' as shown in Figure 3.20, and you will be able to edit the IP and DNS fields. You should know what IP address to put as the gateway and subnet mask.

Step 10. Enter the valid IP address, subnet mask, and default gateway as shown in Figure 3.21.

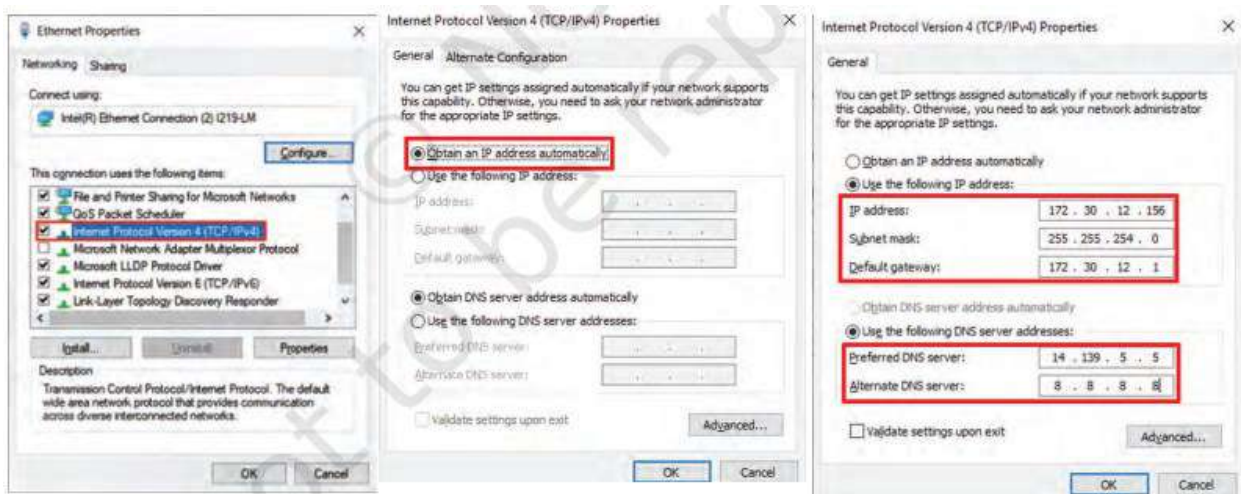

Fig. 3.19 Selecting IPv4

Fig. 3.20 IPv4 properties

Fig. 3.21 Giving IP address

Step 11. You can see the network connection details by clicking on the 'Details' as shown in Figure 3.22. The connection details will be displayed as shown in Figure 3.23.

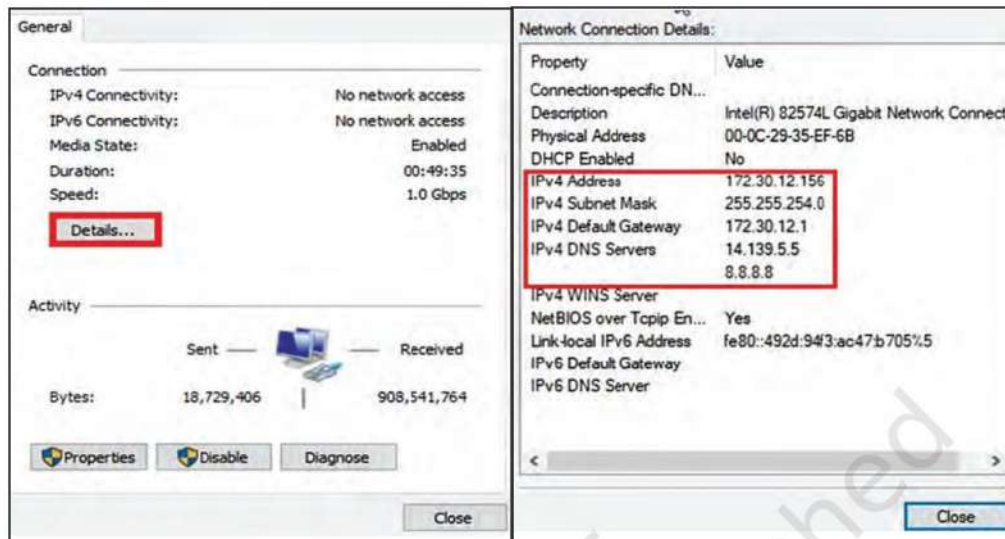

Fig. 3.22 Ethernet status

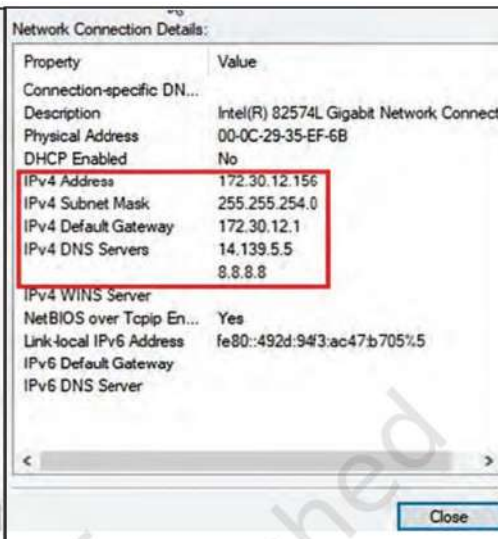

Fig. 3.23 Network connection details

3.5 Performing a Clean Installation of Windows 11

Performing a clean installation of Windows 11 involves wiping your hard drive completely and installing a fresh copy of the operating system. Here's a step-by-step guide:

Practical Activity 3.3 Clean install of windows 11

Step 1. Navigate to the Windows 11 ISO page.

Step 2. Select Windows 11 from the menu under "Download Windows 11 Disk Image (ISO)." If you want to go straight to creating a USB Flash drive, you can download the Windows 11 Installation Media tool from here. See the section below for step-by-step details on how to do that.

Download Windows 11 Disk Image (ISO)

This option is for users that want to create a bootable installation media (USB flash drive, DVD) or create a virtual machine (.ISO file) to install Windows 11. This download is a multi-edition ISO which uses your product key to unlock the correct edition.



Fig. 3.24 download iso image

Step 3. Click Download.

Download Windows 11 Disk Image (ISO)

This option is for users that want to create a bootable installation media (USB flash drive, DVD) or create a virtual machine (.ISO file) to install Windows 11. This download is a multi-edition ISO which uses your product key to unlock the correct edition.

Windows 11 (multi-edition ISO) ▾

⊕ Before you begin

Download

Fig. 3.25 select windows edition

Step 4. Select your language and click confirm.

Select the product language

You'll need to choose the same language when you install Windows. To see what language you're currently using, go to **Time and language** in PC settings or **Region** in Control Panel.

English ▾

Confirm

Fig. 3.26 Product language

Step 5. Click the download button that appears.

Download

Windows 11 English

64-bit Download

Fig. 3.27: Download window 11 64 bit

The ISO file will now download to your computer.

Create a Windows 11 Install Disk with Media Creation Tool

If you don't want to keep a copy of the latest Windows 11 ISO on your storage drive and just want to have a bootable USB Windows 11 install disk, the easiest way is to use Microsoft's media creation tool. Here's how.

1. Connect a USB Flash drive to your PC. It must be at least 8GB and have no data on it you want to keep. This process will overwrite the whole disk.

2. Navigate to Microsoft's Windows 11 Download page.

3. Click **Download Now** under Create Windows 11 Installation Media to download the Media Creation Tool.



Fig. 3.28 windows 11 installation media

4. Launch the Media Creation Tool.

5. Click Accept when shown the license agreement.



Fig. 3.29 window 11 setup accept license terms

3. Select your language and Edition and click Next. The default choices will probably be correct.

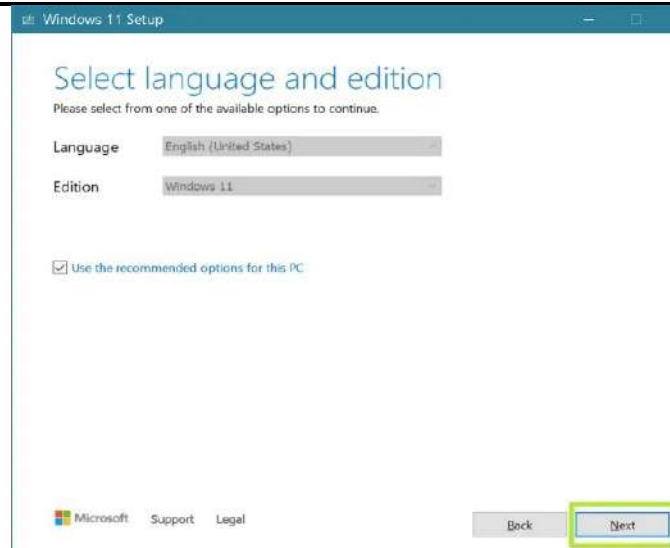

Fig. 3.30 Select language and edition

7. Select USB flash drive and click Next. You can also select ISO file here and create an ISO file instead if you don't have a drive ready.

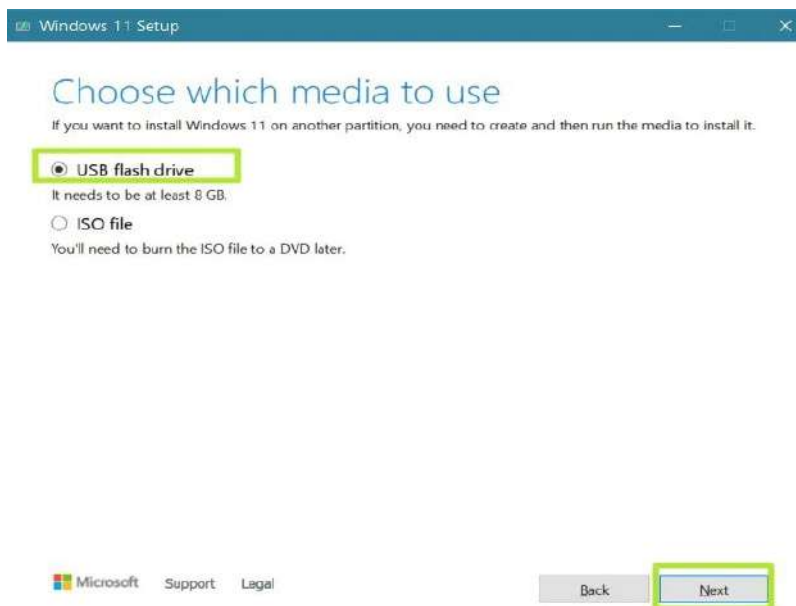

Fig. 3.31 choose a media

8. Select your USB Flash drive (if there's more than one choice) and click Next.



Fig. 3.32 Select USB flash drive

9. You will now have to wait several minutes while your computer downloads Windows 11.

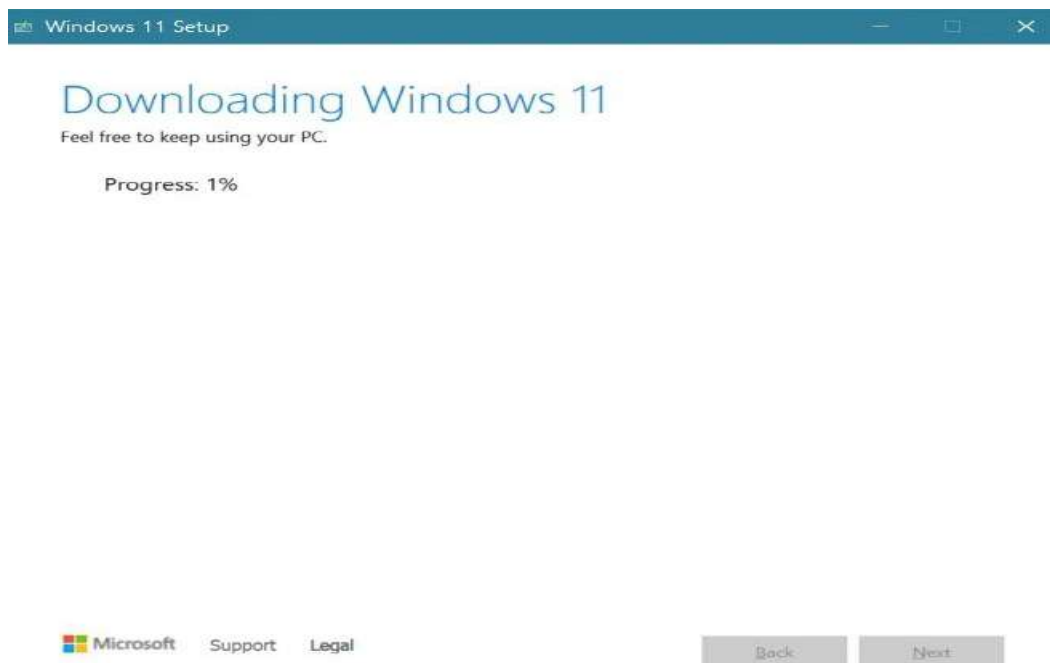

Fig. 3.33 window 11 downloading process

5. Click Finish when it says your USB Flash drive is ready.

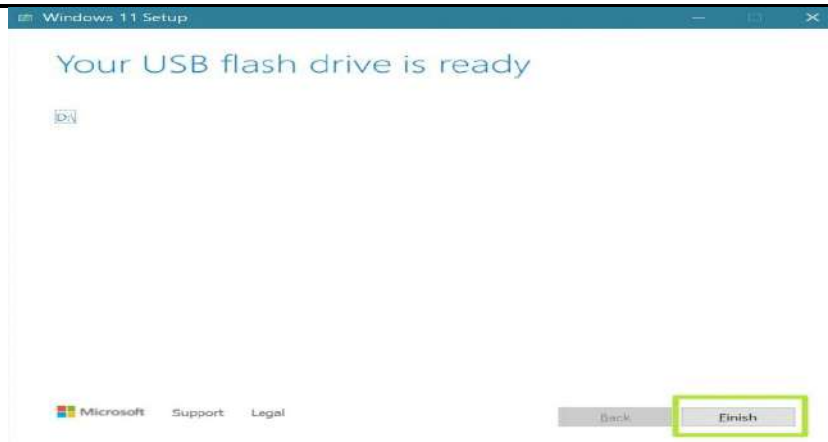

Fig. 3.34 USB flash drive ready

Making a Bootable Windows 11 Install Disk

Unless you're just installing Windows 11 onto a virtual machine, you will need to create a bootable Windows 11 install disk from the data in your Windows 11 ISO file. For that, you'll need an empty USB Flash drive that's at least 8GB. To write or "burn" your ISO file to a USB Flash drive, it's best to use Rufus, a free, third-party utility that will take care of arranging the partitions properly and making the disk bootable. You can also use Rufus to bypass Windows 11's TPM and Secure boot requirements if you choose.

1. Connect your USB Flash drive. Please note that you will be erasing all the data on it.
2. Download and launch Rufus (it does not install).
3. Select your USB drive if it's not already selected by default.

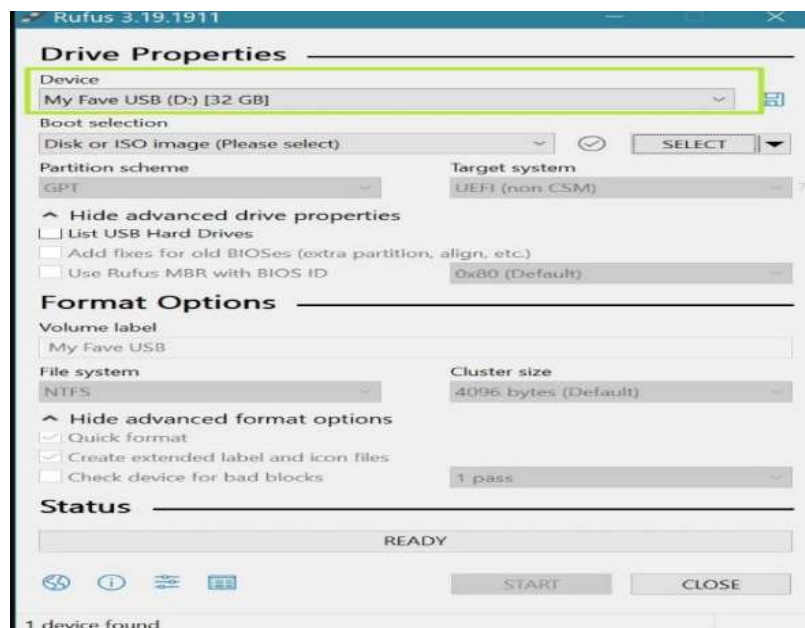

Fig. 3.35 Rufus bootable drive

4. Click Select and choose the ISO file from your storage drive.

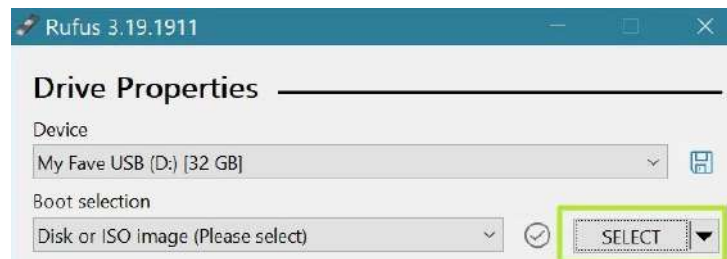

Fig. 3.36 Select the ISO image

5. Click Start at the bottom of the window.



Fig. 3.37 Ready to boot the pen drive

6. Create a second partition and format it as NTFS. It should take all the remaining disk space.

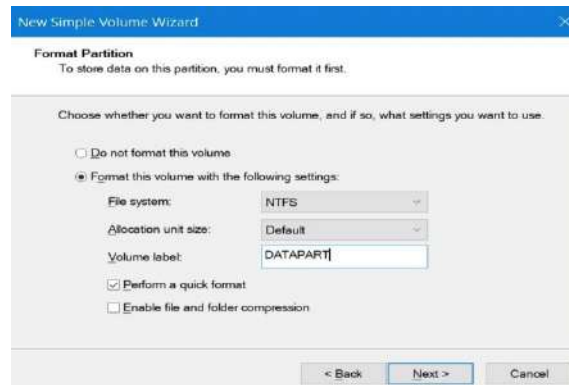

Fig. 3.38 New simple volume wizard

7. Check remove requirement for TPM, 4GB and data collection if you want. These are optional, but recommended and you must click Ok.

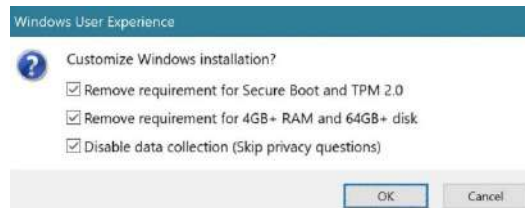

Fig. 3.39 window user experience

8. Click Ok if warned that the process will destroy all data on your USB Flash drive.



Fig. 3.40 warning message to continue this operation

Rufus will now take a few minutes to drive to your drive. When it is done, you will have a USB Flash drive that can boot to install windows.

Installing Windows 11 on the Target PC:

1. Boot your target PC off of the USB installation drive. You may need to hit a key or re-arrange the boot order to boot from USB.
2. Select your language (if it's not already selected) and click Next.



Fig. 3.41 Window setup

3. Click Install now.



Fig. 3.42 Install now

4. Enter your product key or click "I don't have a product key" if you don't have one. You can always enter it later or use Windows 11 as inactivated.



Fig. 3.43 Activation window setup

5. Select the Windows edition if given a choice of editions.

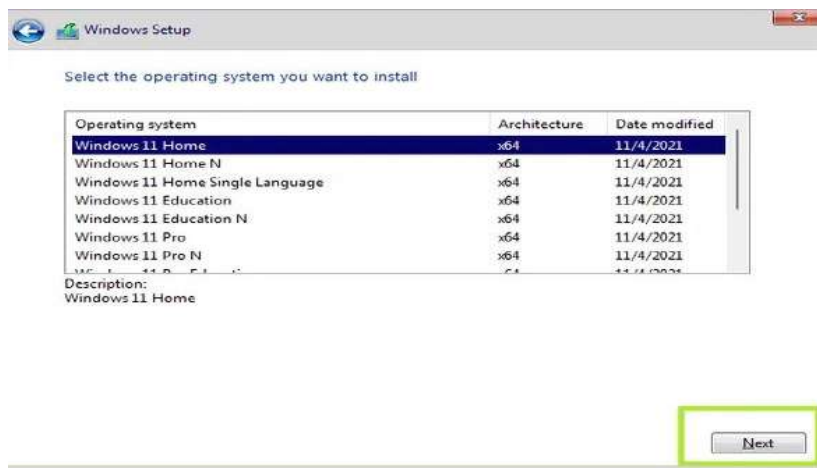

Fig. 3.44 Choose windows edition

6. Accept the license agreement and click Next.

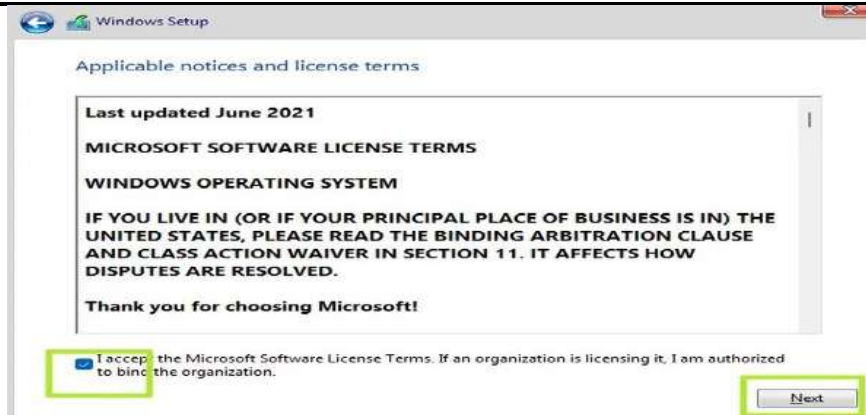

Fig. 3.45 windows accept license

7. Select Custom Install if prompted.

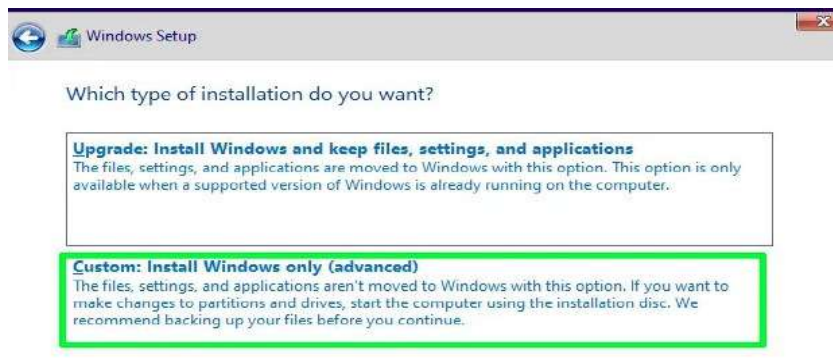

Fig. 3.46 choose type of installation

8. Choose the installation drive and click Next.

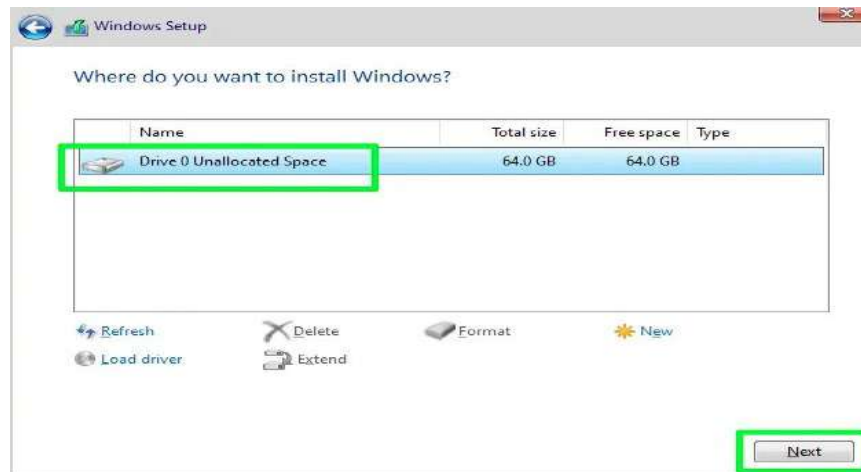

Fig. 3.47 drive unallocated space

9. The installer will copy some files and may reboot at this point.



Fig. 3.48 Installing windows copy files

10. Select your country or region (if it's not selected) and **click Yes**. Also, **select your keyboard layout** when prompted.

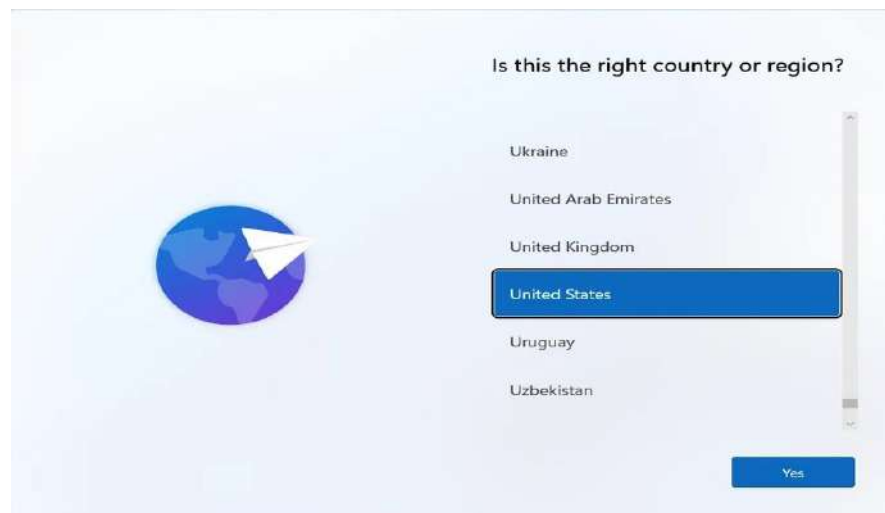

Fig. 3.49 choose the region

11. Name your device and **click Next**.

12. Sign in with your Microsoft account.

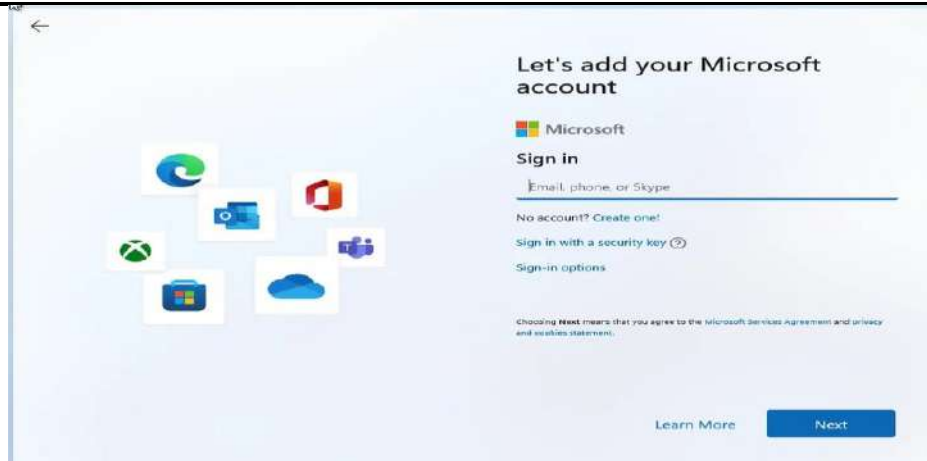

Fig. 3.50 add Microsoft account

13. Create a PIN for quick logins.

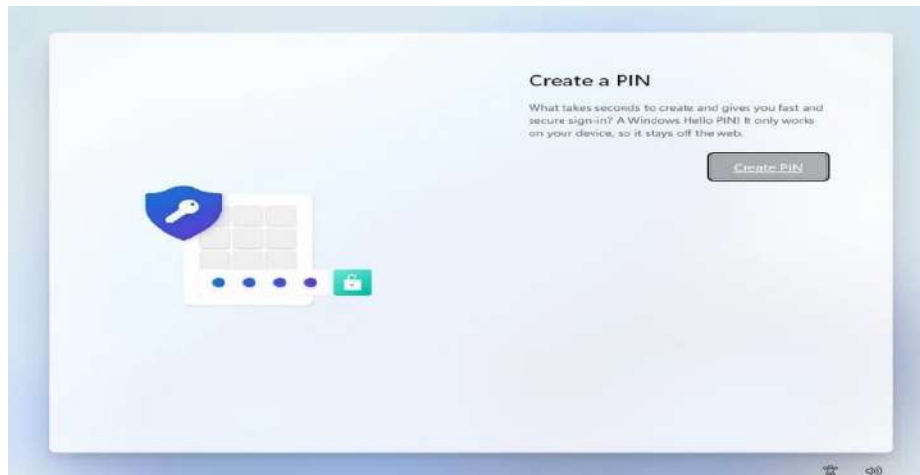

Fig. 3.51 create a pin

14. Click "Set up as new device" (or you can restore a previous config).

15. Click Skip if asked to customize your user experience. This is not necessary.

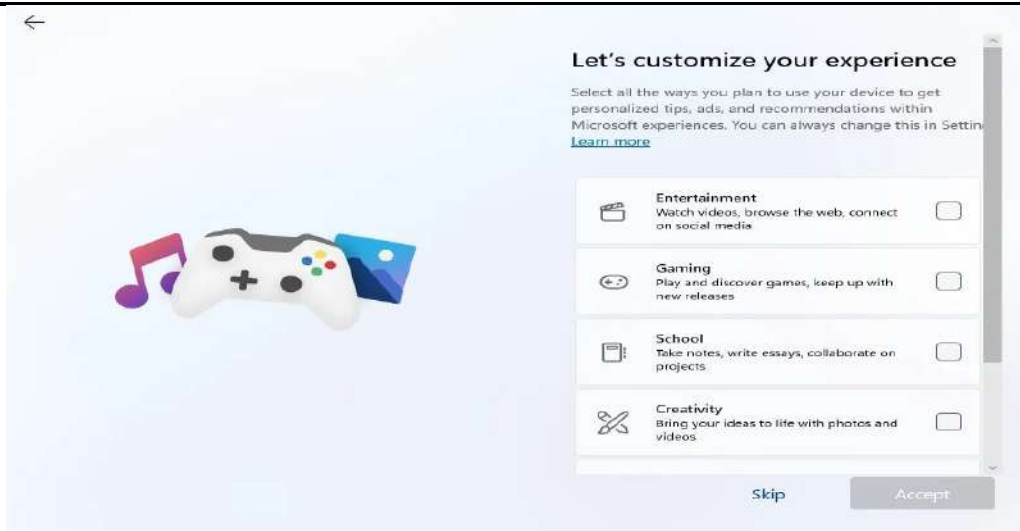

Fig. 3.52 choose the customize

13. Click Next on the Microsoft Account and OneDrive screen.



Fig. 3.53 add Microsoft account

17. Windows will now (finally) finalize the installation of Windows 11 using all of the settings you selected up to this point. Windows will ask you to wait will the installation wraps up, which only takes a few minutes on average.

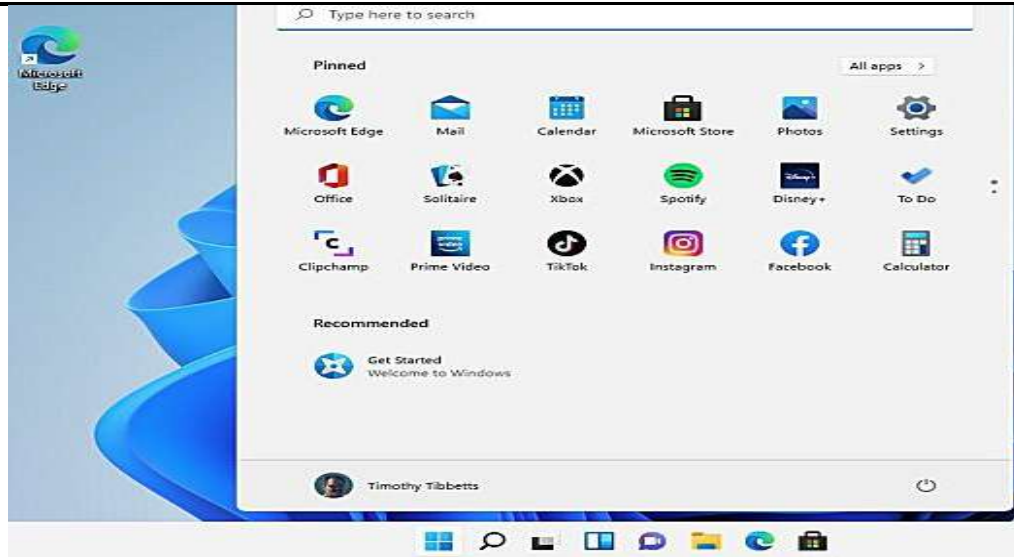

Fig. 3.54 add Microsoft account

3.8 Old version- Performing a Clean Installation of Windows 10

To perform a clean installation of Windows 10, insert a bootable media DVD or USB pen drive in your computer system, and press any key to boot from the bootable disk as shown in Figure 3.55. Let the disk allow the loading of the setup file as shown in Figure 3.56. Follow the steps below for clean installation of Windows 10.



Fig. 3.55 Press any key for booting



Fig. 3.56 Loading setup file

- (i) Insert a bootable media DVD or USB pen drive in your computer system. Provide the details of language, time zone, and keyboard layout as shown in Figure 3.57. Then click on the 'Next' button.
- (ii) Click the 'Install now' button as shown in Figure 3.58.



Fig. 3.57 Select language, time, and currency Fig. 3.58 Installation window and input

- (iii) In the next window, you will be asked to enter the product key. Enter it and click on the 'Next' button to proceed. In case you don't have the product key currently, then you can skip to enter the product key by clicking on the option 'I don't have a product key' to continue the installation as shown in Figure 3.59 below.
- (iv) A new window as shown in Figure 3.60 will appear where you have to accept the licence terms by putting the tick () on the checkbox 'I accept the license terms'.
- (v) Click the 'Next' button.
- (vi) Click on the 'Custom: Install Windows only (advanced)' option.

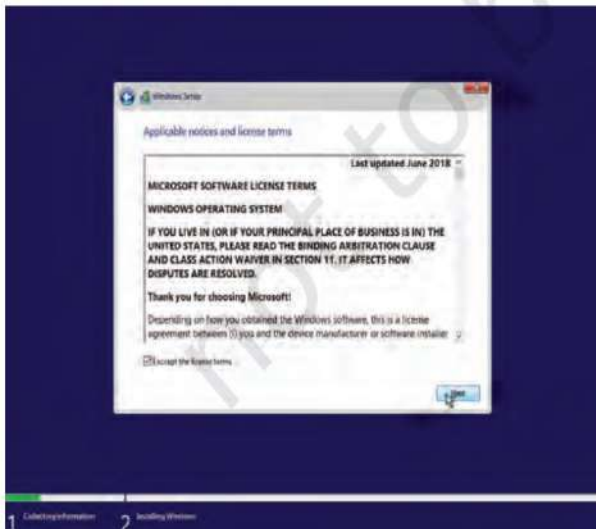

Fig. 3.59 License terms

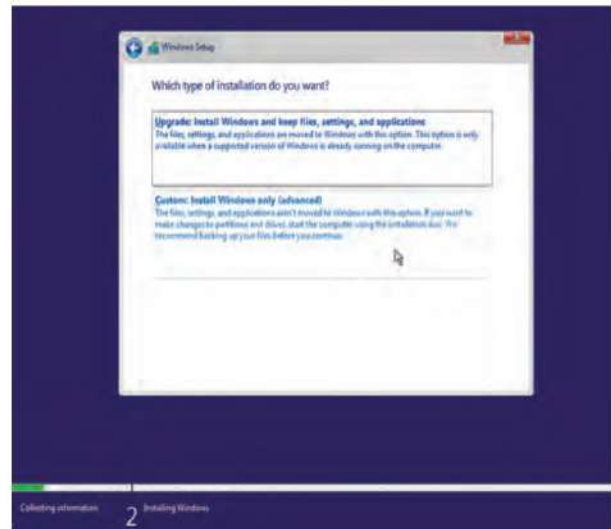

Fig. 3.60 Selecting installation setup window

- (vii) Select the partition with the current installation of Windows (usually "Drive 0"), and click

the 'Delete' button to remove it from the hard drive.

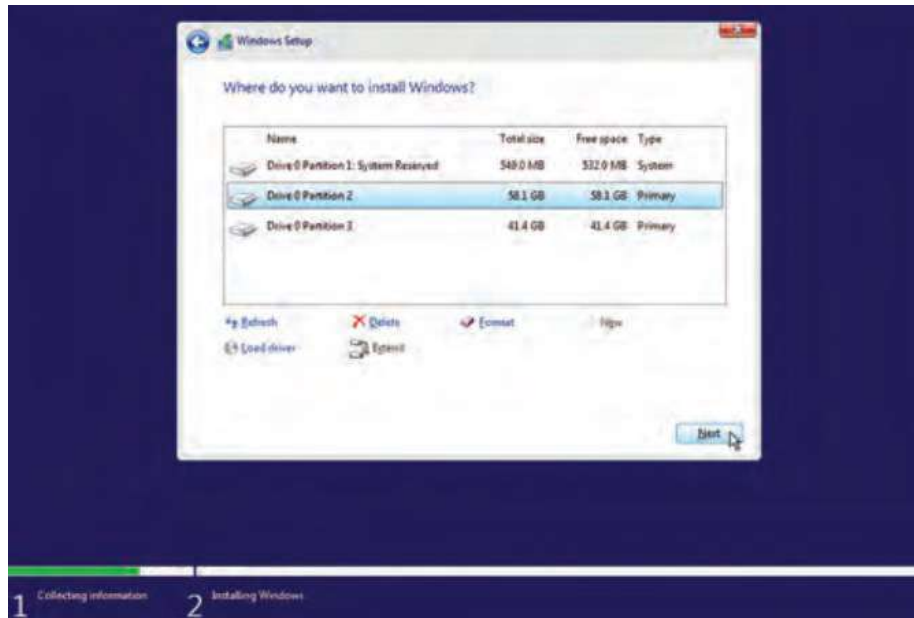

Fig. 3.61 Partition window

(viii) Click the 'Yes' button to confirm the deletion.

(ix) Select the empty drive ('Drive 0 Unallocated Space') and click on the 'Next' button as shown in Figure 3.63.

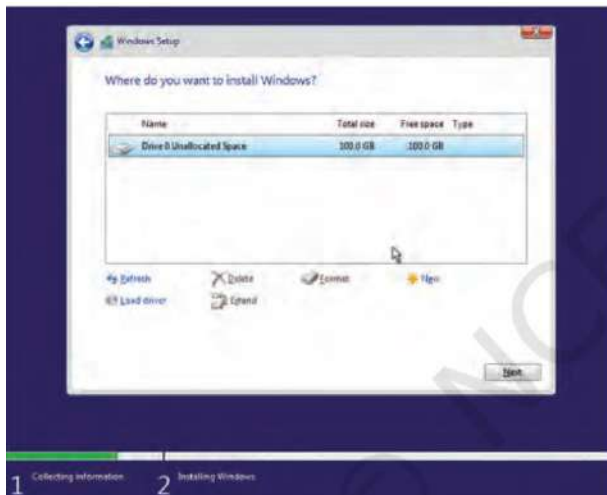

Fig. 3.62 Drive 0 unallocated space

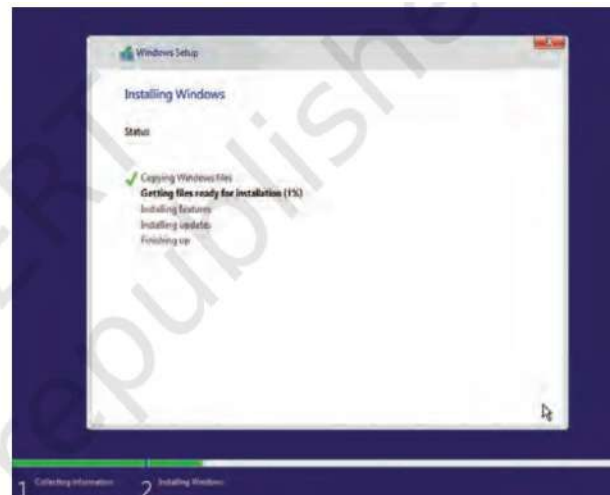

Fig. 3.63 Installing Windows

(x) After completion of these steps, the set-up will proceed to install Windows 10 as shown in Figure 3.68.

(xi) After complete installation, the initial, window will appear on the computer screen as shown in Figure 3.69.



Fig. 3.64 Home window of windows 10

Summary

After installation, certain settings must be configured to ensure Windows functions properly. This includes network setup, display settings, time and language preferences, user control, and application installation. These steps make the system secure and user-friendly.

Check Your Progress

A. Multiple choice Question (MCQ)

1. What might cause icons to go missing from the Windows 10 desktop? (a) Corrupted files (b) Incorrect display settings (c) Malware or viruses (d) All of the above
2. Where can you set the date and time in Windows 10? (a) Control Panel (b) Task Manager (c) Settings app (d) File Explorer
3. How can you access the taskbar settings in Windows 10? (a) Right-click on the taskbar (b) Open Task Manager (c) Go to Control Panel (d) Use File Explorer
4. What is Safe Mode used for in Windows? (a) To speed up the computer (b) To fix hardware issues (c) To troubleshoot software problems (d) To update Windows
5. How can you resize the taskbar in Windows 10? (a) By dragging the edge of the taskbar (b) Using Task Manager (c) Through the Control Panel (d) In File Explorer
6. Which shortcut opens File Explorer in Windows 10? (a) Ctrl + E (b) Windows Key + E (c) Alt + E (d) Shift + E
7. Which of the following is NOT a section in File Explorer? (a) Quick Access (b) System Restore (c) This PC (d) Network
8. Where can you change the region and language settings in Windows 10? (a) Control Panel (b) Settings app (c) Task Manager (d) File Explorer
9. Where can you configure a static IP address in Windows 10? (a) Control Panel (b) Settings app (c) Network and Sharing Center (d) Device Manager
10. What is the first step in performing a clean installation of Windows 11? (a) Download the ISO file (b) Backup important data (c) Create a bootable USB drive (d) Install the operating system

B. Fill in the Blank

1. One possible reason for missing desktop icons in Windows 10 is a _____ issue.
2. The date and time settings in Windows 10 can be adjusted through the _____ app.
3. To access taskbar settings in Windows 10, you can right-click on the _____.
4. Safe Mode is used in Windows to troubleshoot _____ problems.
5. You can resize the taskbar in Windows 10 by dragging the _____ of the taskbar.
6. The shortcut to open File Explorer in Windows 10 is _____ + E.
7. One of the sections in File Explorer is called _____ Access.
8. Region and language settings in Windows 10 can be changed through the _____ app.
9. A static IP address can be configured in Windows 10 using the _____ and Sharing Center.
10. The first step in performing a clean installation of Windows 11 is to _____ important data.

C. True or False

1. Missing desktop icons in Windows 10 can sometimes be caused by incorrect display settings.
2. The date and time in Windows 10 can only be set through the Control Panel.
3. You can access the taskbar settings in Windows 10 by right-clicking on the taskbar.
4. Safe Mode is used to speed up the computer by disabling unnecessary software.
5. In Windows 10, the taskbar cannot be resized.
6. The shortcut to open File Explorer in Windows 10 is Windows Key + E.
7. One of the sections in File Explorer is called System Restore.
8. You can change the region and language settings in Windows 10 through the Settings app.
9. A static IP address can be configured in Windows 10 using the Network and Sharing Center.
10. The first step in performing a clean installation of Windows 11 is to download the ISO file.

D. Short Question?

1. Describe the possible reasons for desktop icons going missing in Windows 10 and outline the steps you would take to troubleshoot and resolve this issue.
2. Explain how to set the date and time in Windows 10, including how to configure the system to automatically adjust for daylight saving time and synchronize with an

internet time server.

3. Discuss the functionalities of the Windows 10 taskbar. How can you customize the taskbar to better suit your workflow? Include details on pinning applications, moving the taskbar, and adjusting its properties.
4. What is Safe Mode in Windows 10? Describe the steps to boot into Safe Mode and explain how it can be used to troubleshoot and fix issues related to the taskbar.
5. Describe the process of resizing the taskbar in Windows 10. Why might someone want to resize their taskbar, and what are the potential benefits and drawbacks of doing so?
6. File Explorer is a fundamental tool in Windows operating systems. Explain its main features and functionalities. How has File Explorer evolved across different versions of Windows?
7. Identify and describe the different sections of File Explorer in Windows 10. How can users customize these sections to improve their file management experience?
8. How do you change region and language settings in Windows 10? Discuss the impact of these settings on date, time, currency formats, and language preferences. How can these settings be useful for users in a multilingual environment?
9. Explain the process of configuring a static IP address in Windows 10. What are the advantages and disadvantages of using a static IP address compared to a dynamic IP address?
10. Describe the steps involved in performing a clean installation of Windows 11. What preparations should be made before starting the installation, and what are the key differences between a clean installation and an upgrade?

MODULE 3**Installation and Configuration of Linux Operating System****Module Overview**

Installing and configuring a Linux operating system involves several steps that ensure the system is tailored to the user's needs. The process begins by choosing a Linux distribution, such as Ubuntu, Fedora, or CentOS, and creating a bootable installation media, like a USB drive or DVD. The technician boots the system from this media and follows the guided installation steps, which include selecting the language, time zone, and partitioning the hard drive.

After the OS is installed, the configuration phase begins. This includes setting up user accounts, configuring network settings, and installing essential software packages through a package manager like APT or YUM. It's crucial to install updates and security patches to keep the system secure. Depending on the user's requirements, additional configurations might involve setting up a firewall, configuring system services, and customizing the desktop environment for optimal performance and usability.

Module Structure

Session 1: Installation of Ubuntu Linux

Session 2: Perform post installation task in Linux operating system

Session 3: Install and Configure Peripheral devices

Session 1. Installation of Ubuntu Linux**Linux Operating System**

Linux, an open-source operating system, made its debut on September 17, 1991, thanks to Linus Torvalds. Similar to Windows, macOS, and Android, Linux also shares similarities with Unix operating systems, reflecting in comparable commands. It's freely accessible for both commercial and non-commercial purposes, enabling programmers to modify the Linux kernel, creating new distributions.

In recent times, Linux has made remarkable strides, offering numerous beneficial features for both companies and home users. Consequently, it has emerged as one of the most prevalent operating systems in the IT industry. Moreover, it's readily available for download at no cost

from the internet.

Minimum system requirements for Ubuntu 24.04 LTS:

As of my last update, which was in January 2022, Ubuntu 24.04 LTS had not been released yet, and specific system requirements for it were not available. However, based on historical trends and the typical progression of system requirements in Ubuntu releases, we can make an educated guess about the expected minimum system requirements.

For Ubuntu 22.04 LTS, which is the release preceding 24.04 LTS, the minimum system requirements were as follows:

- Processor: 1 GHz dual-core processor or better
- RAM: 2 GB RAM
- Storage: 25 GB of hard disk space
- Graphics: VGA capable of 1024x768 screen resolution
- Network: Either a wired Ethernet or wireless adapter

It's important to note that these are general guidelines, and actual system requirements may vary based on factors such as the desktop environment (e.g., GNOME, KDE, Xfce) and specific software requirements. Additionally, newer releases of Ubuntu may have slightly higher system requirements to accommodate improvements and new features.

Linux operating system distributions

Linux operating system distributions, often referred to as "distros," come in various flavors, each tailored to different user needs and preferences. Here's an overview of some popular Linux distributions, their key features, and typical system requirements:

Linux distributions	key features	System requirements
Ubuntu:	Ubuntu is known for its user-friendly interface and extensive software repository. It offers long-term support (LTS) releases with five years of security updates, making it suitable for both desktop and server use.	Minimum requirements typically include a 1 GHz processor, 2 GB of RAM, and 25 GB of disk space.
Fedora:	Fedora focuses on integrating the latest open-source technologies and serves as a testing ground for future Red Hat Enterprise Linux (RHEL) releases. It includes GNOME as the default desktop environment and emphasizes security features.	Recommended specifications include a 2 GHz dual-core processor, 4 GB of RAM, and 15 GB of disk space.

Debian:	Debian is known for its stability, reliability, and commitment to free software principles. It offers a wide range of software packages and supports multiple desktop environments, including GNOME, KDE, and Xfce.	Minimum requirements typically include a 1 GHz processor, 512 MB of RAM, and 10 GB of disk space.
CentOS	CentOS is a community-driven distribution based on the source code of Red Hat Enterprise Linux (RHEL). It provides a stable and secure platform suitable for server deployments, with long-term support and regular updates.	Minimum requirements typically include a 1 GHz processor, 1 GB of RAM, and 10 GB of disk space
Arch Linux:	Arch Linux follows a minimalist philosophy, offering a lightweight and customizable system. It employs a rolling release model, providing continuous updates to the latest software versions.	Arch Linux has relatively low hardware requirements, typically requiring a 64-bit processor, 512 MB of RAM, and 2 GB of disk space.
Linux Mint:	Linux Mint provides an elegant and user-friendly desktop environment based on Ubuntu LTS releases. It includes proprietary multimedia codecs and additional software out of the box for enhanced multimedia support.	Minimum requirements typically include a 1 GHz processor, 1 GB of RAM (2 GB recommended), and 15 GB of disk space.

Types of Linux installation

Linux installations can vary depending on the specific distribution and user preferences. Here are some common types of Linux installations:

1. **Graphical Installation:** This is the most user-friendly method and typically involves booting from a live USB or DVD and using a graphical installer to guide the user through the installation process. The installer often provides options for partitioning the disk, selecting software packages, and configuring system settings.
2. **Text-Based Installation:** Some Linux distributions offer a text-based installation option, which is similar to a graphical installation but uses a text-based interface instead. This method may appeal to users who prefer a more lightweight or minimal installation environment.
3. **Network Installation:** Network installation involves booting from a network image and installing the operating system over a network connection. This method is useful for deploying Linux on multiple machines simultaneously or for installing on systems without optical drives or USB ports.
4. **Unattended Installation:** Also known as automated or silent installation, this method al-

allows users to install Linux without manual intervention. It involves creating a configuration file or script that specifies installation options and settings, which the installer then follows automatically.

5. **Dual-Boot Installation:** Dual-booting involves installing Linux alongside another operating system, such as Windows, on the same computer. Users can choose which operating system to boot into each time the computer starts. This method allows users to try out Linux without fully committing to it as their primary operating system.
6. **Virtual Machine Installation:** Users can install Linux in a virtual machine (VM) on their existing operating system using virtualization software such as VirtualBox or VMware. This allows for experimentation with Linux without affecting the host operating system.
7. **Diskless Installation:** Diskless installations run Linux entirely from RAM or over a network without requiring a local disk drive. This method is commonly used for thin clients, embedded systems, and diskless workstations.

Creating Ubuntu Linux bootable disk

Ubuntu is a popular operating system based on the Linux kernel. It is known for its security, stability, and ease of use. One of the easiest ways to try out Ubuntu is by creating a bootable USB startup disk. In this article, we will discuss three ways to create a bootable Ubuntu USB startup disk.

Using Rufus on Windows

Rufus stands out as a free and open-source utility designed for crafting bootable USB drives. Tailored for Windows, it offers a straightforward interface. Below are the steps to fashion a bootable Ubuntu USB startup disk using Rufus on Windows:

Activity 1

Practical Activity: 1 Demonstrate to Create Ubuntu Linux bootable disk

- Step 1. Download the Ubuntu ISO image from the official website.
- Step 2. Get Rufus from its official website and install it on your Windows PC.
- Step 3. Insert a USB flash drive with at least 2GB capacity.
- Step 4. Launch Rufus and choose the USB flash drive you want to use.
- Step 5. In the "Boot selection" section, click "Select" and pick the Ubuntu ISO image you downloaded earlier.
- Step 6. For "Partition scheme," choose "MBR" for BIOS systems or "GPT" for UEFI systems.
- Step 7. For "File system," select "FAT32."
- Step 8. Click "Start" and let Rufus create the bootable Ubuntu USB startup disk.

Using Etcher on macOS

Etcher is a free and open-source tool that can be used to create bootable USB disks. It is available for macOS, Windows, and Linux. Here are steps to create a bootable Ubuntu USB startup disk using Etcher on macOS –

Practical Activity: Demonstrate to Create Ubuntu Linux bootable disk using macOS

Get the Ubuntu ISO image from the official website.

Step 1. Download Etcher from its official website and install it on your macOS device.

Step 2. Insert a USB flash drive with at least 2GB capacity.

Step 3. Open Etcher and choose the Ubuntu ISO image you downloaded previously.

Step 4. Select the USB flash drive you wish to use.

Step 5. Click the "Flash!" button and allow Etcher to create the bootable Ubuntu USB startup disk.

Using dd Command on Linux

If you are using a Linux machine, you can use dd command to create a bootable Ubuntu USB startup disk. Here are steps to create a bootable Ubuntu USB startup disk using dd command on Linux –

Practical Activity: Demonstrate to Create Ubuntu Linux bootable disk using dd Command

Step 1. Download the Ubuntu ISO image from the official website.

Step 2. Insert a USB flash drive with at least 2GB capacity.

Step 3. Open the terminal and run the following command to check the name of the USB flash drive: `sudo fdisk -l`

Step 4. Identify the name of the USB flash drive from the list of devices, such as `"/dev/sdb"` or `"/dev/sdc"`.

Step 5. Unmount the USB flash drive by running the following command: `sudo umount /dev/sdb1` Replace `"/dev/sdb1"` with the name of the USB flash drive you identified earlier.

Step 6. Write the Ubuntu ISO image to the USB flash drive by running the following command: `sudo dd bs=4M if=/path/to/ubuntu-xx.xx-desktop-amd64.iso of=/dev/sdb conv=f` Replace `"/path/to/ubuntu-xx.xx-desktop-amd64.iso"` with the path to the Ubuntu ISO image you downloaded earlier, and `"/dev/sdb"` with the name of the USB flash drive you identified earlier.

Step 7. Wait for the "dd" command to complete. This may take a few minutes.

Step 8. Once the process is complete, you can safely remove the USB flash drive from your Linux machine and use it to boot into Ubuntu.

Create a bootable USB stick with Rufus on Windows Requirements

You will need:

- A 4GB or larger USB stick/flash drive
- Microsoft Windows XP or later
- Rufus, a free and open source USB stick writing tool
- An Ubuntu ISO file. See Get Ubuntu for download links.

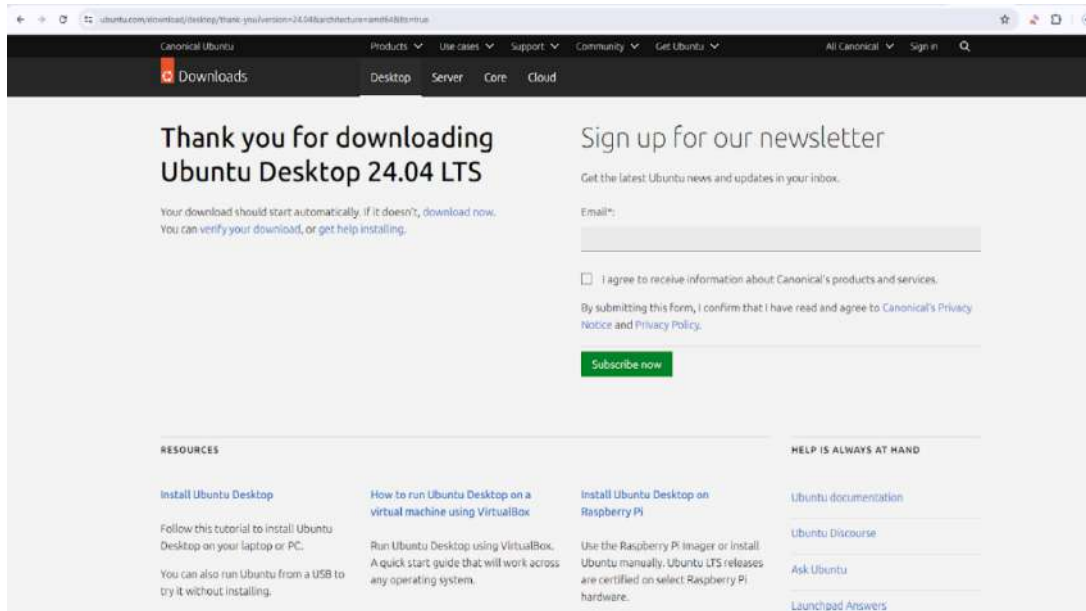

USB selection

Here are the steps to configure your USB device in Rufus:

1. Open Rufus.
2. Insert your USB stick.
3. Rufus will automatically detect and display the device within the Device field.
4. If the selected Device is incorrect (for instance, if you have multiple USB storage devices), choose the correct one from the drop-down menu in the device field.

4. Select the Ubuntu ISO file

To select the Ubuntu ISO file you downloaded previously, click the SELECT to the right of “Boot selection”. If this is the only ISO file present in the Downloads folder you will only see one file listed.

Select the appropriate ISO file and click on Open.

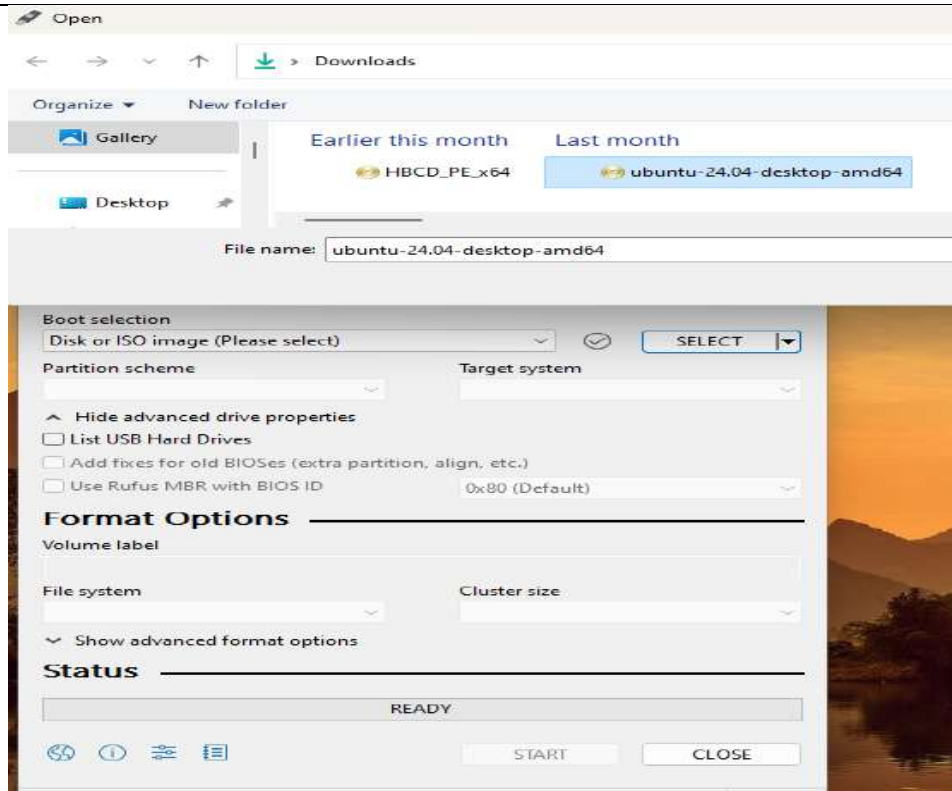

5. Write the ISO

The Volume label will automatically adjust to match the selected ISO.

Keep all other settings at their default values and click START to begin the writing process.

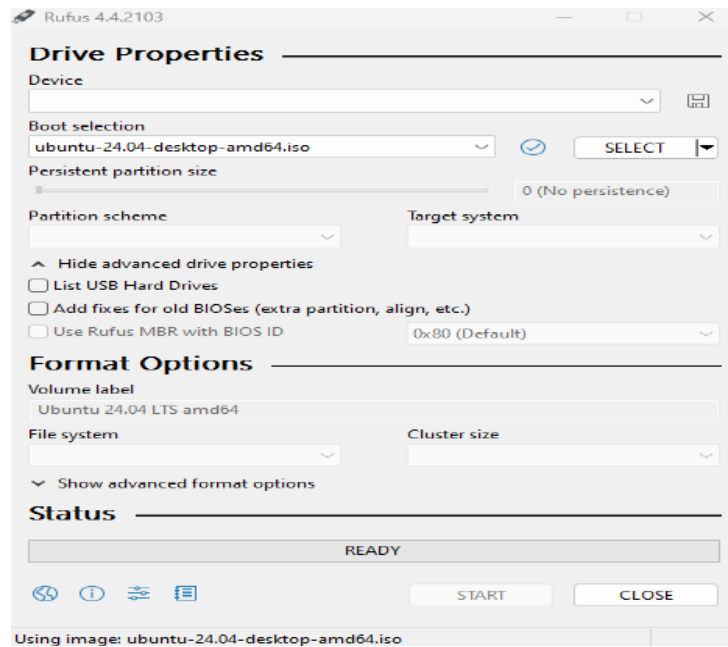

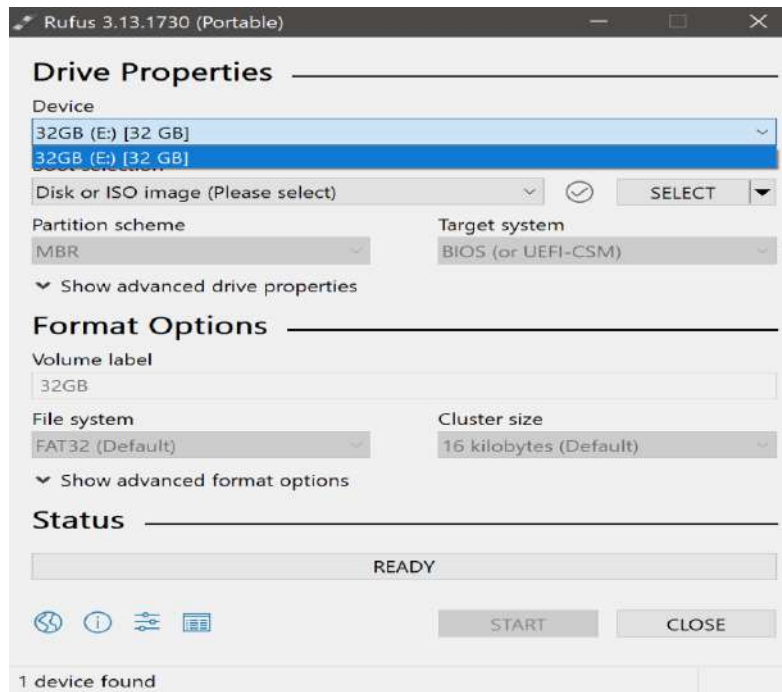

7. Write warnings

You will then be alerted that Rufus has detected that the Ubuntu ISO is an ISO Hybrid image. This means the same image file can be used as the source for both a DVD and a USB stick without requiring conversion.

Keep Write in ISO Image mode selected and click on OK to continue.

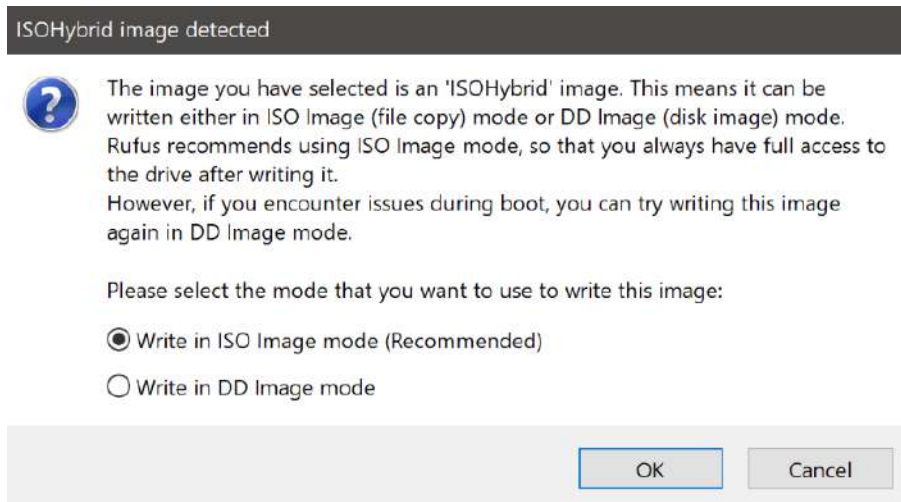

Rufus will also provide a warning indicating that all data on your chosen USB device will be erased. This is an opportune time to double-check if you have selected the correct device before proceeding. Once you are certain, click OK to continue.

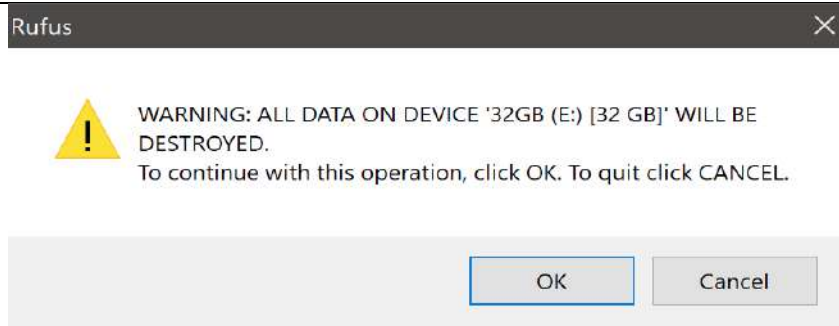

8. Writing the ISO

The ISO will now be written to your USB stick, and the progress bar in Rufus will give you some indication of where you are in the process. With a reasonably modern machine, this should take around 10 minutes. Total elapsed time is shown in the lower right corner of the Rufus window.

9. Installation complete

When Rufus has finished writing the USB device, the Status bar will be filled green and the word READY will appear in the center. Select CLOSE to complete the write process.

Demonstrate to Clean installation of Ubuntu 24.04 LTS on a new computer.

Canonical has recently unveiled its newest operating system, Ubuntu 24.04, bearing the codename "Noble Numbat." This release is categorized as an LTS (Long Term Support), promising users updates and support for the next five years. We will guide you through the step-by-step installation process of Ubuntu 24.04 LTS desktop, accompanied by screenshots. Before delving into the installation procedure, let's take a quick look at the fresh and enhanced features introduced in this edition:

- Introduction of the latest GNOME 46 Desktop Environment.
- Integration of the latest Linux Kernel 6.8.
- Significant enhancements in Software Center and Tweaks.
- Implementation of a much-improved installer for an enhanced user experience.
- Addition of the Dynamic Workspace Indicator.
- Improved Remote RDP Login feature in tandem with GNOME 46.
- Inclusion of Pipe Wire as the default sound server.
- The installer will perform a minimal installation if the 'extended installation' option is not chosen.

Requirements:

- At least 4 GB of RAM
- A dual-core processor clocked at 2 GHz
- 25 GB of available disk space
- Internet connectivity (optional)

- Installation media (bootable USB or DVD)

Practical Activity: Demonstrate to clean installation of Ubuntu operating system on a new computer.

Step 1. Download the Ubuntu 24.04 ISO File

Navigate to the official Ubuntu website (<https://ubuntu.com/download/desktop>) and download the ISO file.

After downloading the ISO file, create the installation media by burning the ISO file onto a USB or DVD drive. If you're using Windows, you can utilize the "Rufus" software to create a bootable USB drive with the ISO file. On Linux, follow these steps:

Step 2. Boot System with Installation Media.

Start your target system using the installation media, which, in our case, is the bootable USB drive created in the previous step. (In the BIOS settings, adjust the boot order to prioritize the USB drive over the hard disk.) Once the system boots up with the installation media, you will encounter the following screen. Select "Try or Install Ubuntu".



Step 3. Choose Your Language

You'll be asked to select your preferred language in this step. Pick the appropriate language, then click on Next.

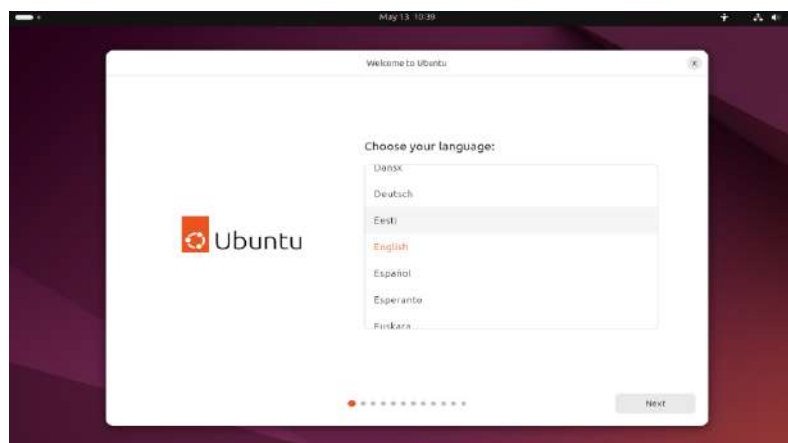

Step 4. Customize Ubuntu 24.04 Settings

In this step, the installer provides you with options to customize your Ubuntu settings, as shown below. However, you can also customize these settings later after installation.

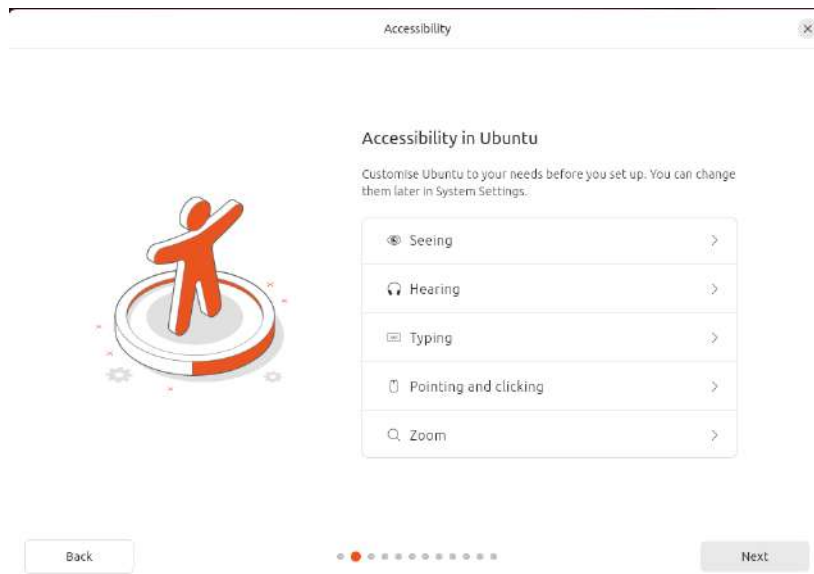
**Step 5. Select Your Preferred Keyboard Layout**

Choose the keyboard layout that best suits your needs for this installation, then click Next.

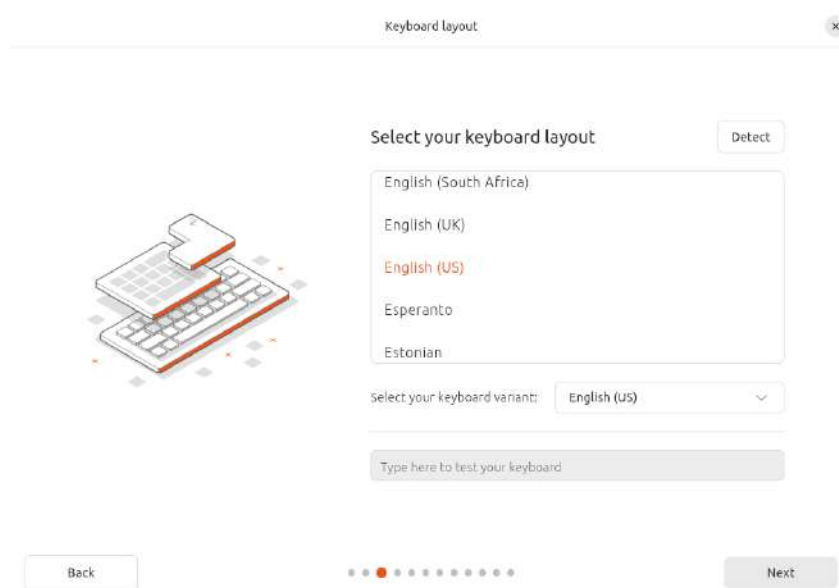
**Step 6. Select Install Ubuntu**

In case, your system is connected to the internet then choose “Use Wired Connection” else select “Do not Connect to the Internet”.

In my case, my system is connected to the internet so, I will choose first option.

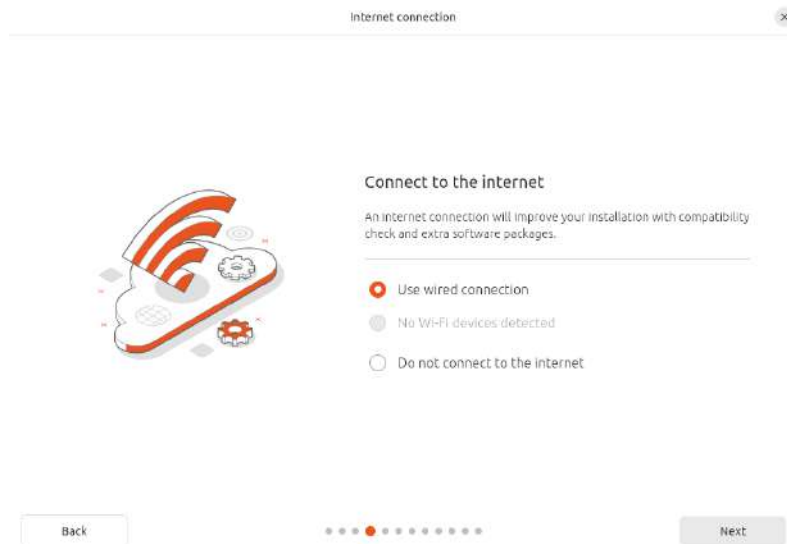

In the following window, select “Install Ubuntu” and then click Next.

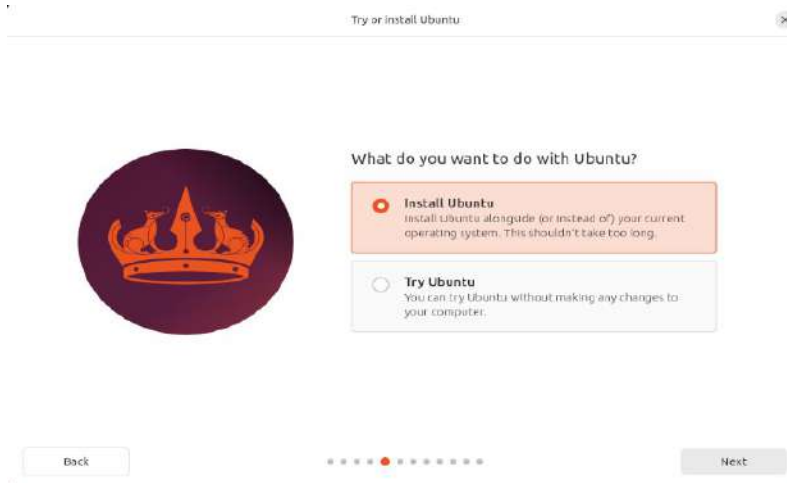

Step 7. Type of Installation

At this step, the installer will prompt you “how do you like to install Ubuntu”.

You have two options:

1. Interactive Installation: This type of installation involves user interaction throughout the installation process.
2. Automated Installation: As the name suggests, this is an automated installation method. However, it requires preparation of an "autoinstall.yaml" file containing all the necessary settings or parameters for the OS installation.

For this guide, we will proceed with the interactive installation method.

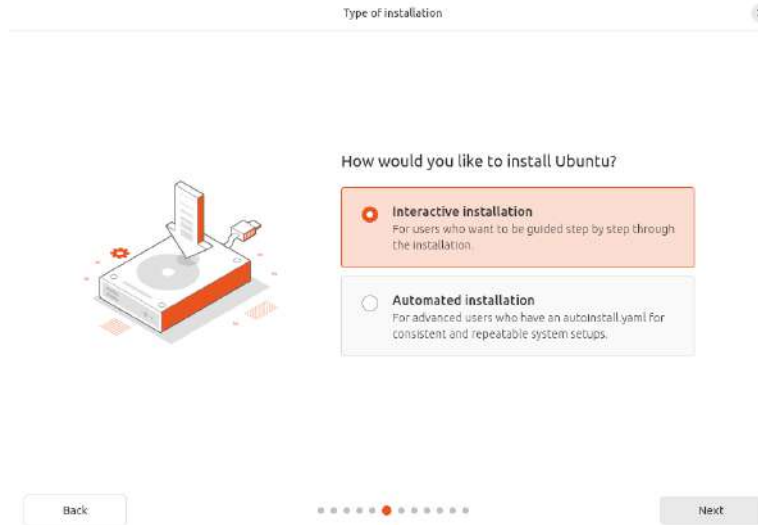

Step 8. Click on [Next](#)

In the following window, choose “[Extended Selection](#)” to install desktop tools, utilities and web browser.

If you choose “[Default Selection](#)” then installer will install only desktop basic utilities.

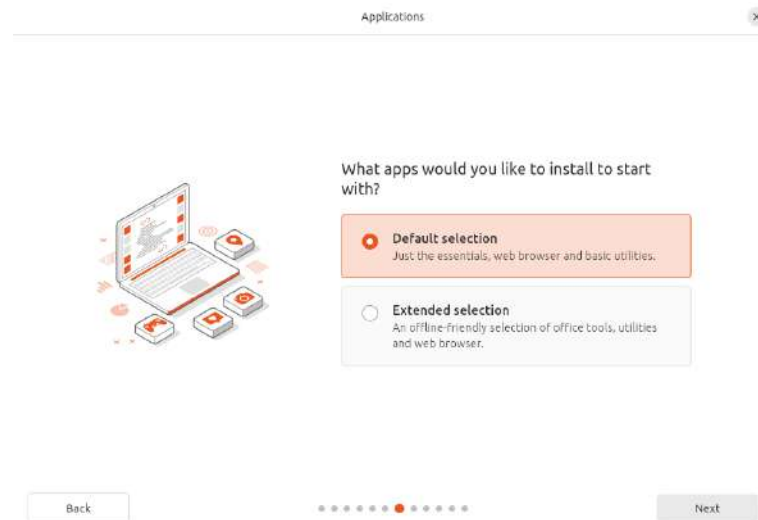

Step 9. Install Third-Party Software for Graphics and Wi-Fi. If you wish to install updates and third-party software for graphics and Wi-Fi during the installation, select both options, provided your system is connected to the internet. If your system is not connected to the internet or you prefer not to install updates during the installation, uncheck both options and then click on Next.

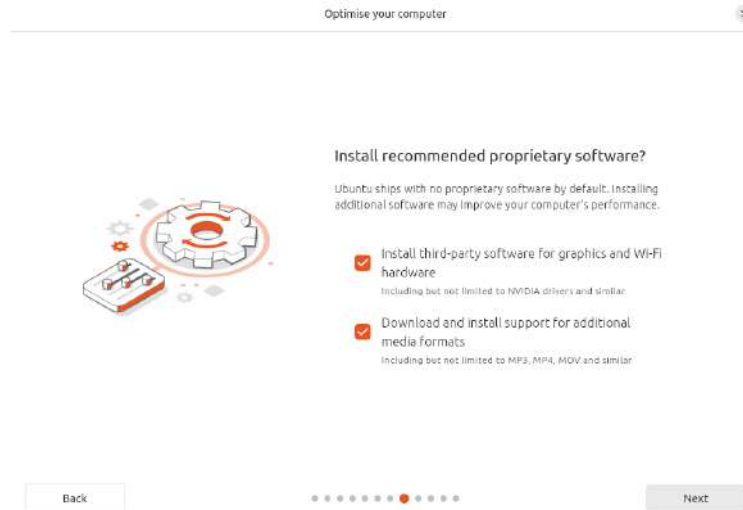

Step 10. Disk Partition Scheme

In this step, the installer will ask you how you want to create the partition scheme on the disk. You have two options:

1. Erase Disk and Install Ubuntu: With this method, the installer will erase all data on the disk and create the necessary partitions automatically. This is recommended for users new to Linux.
2. Manual Installation: With this method, you can manually create partitions on the disk according to your requirements.

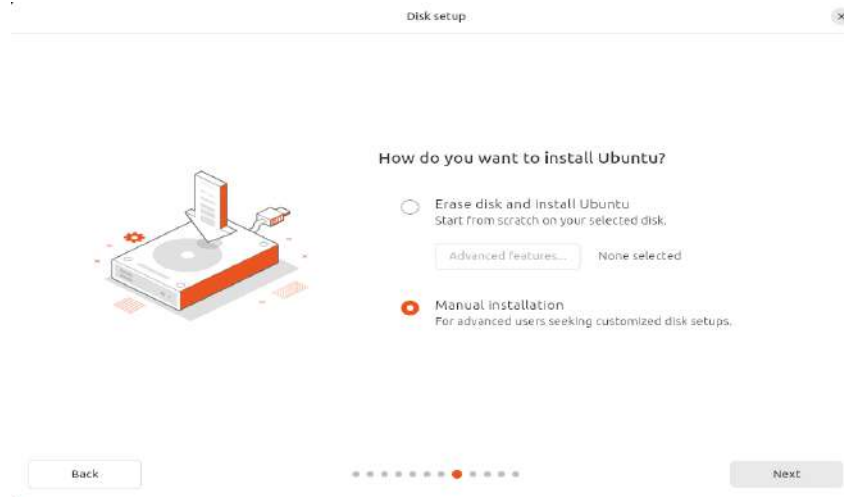

In this guide, I will demonstrate how to create manual partitions by selecting the 'Manual Installation' method.

Step 11. Click "Next" to continue.

For Ubuntu 24.04, I'll be partitioning an 80GB disk as follows:

- /boot: 2GB (ext4 file system)
- / (root): 20GB (ext4 file system)
- /home: 50GB (ext4 file system)
- Swap: 2GB

On the subsequent screen, select the unallocated disk space, click on the "+" symbol, and begin creating partitions.

We'll start by creating the first partition as /boot with a size of 2GB.

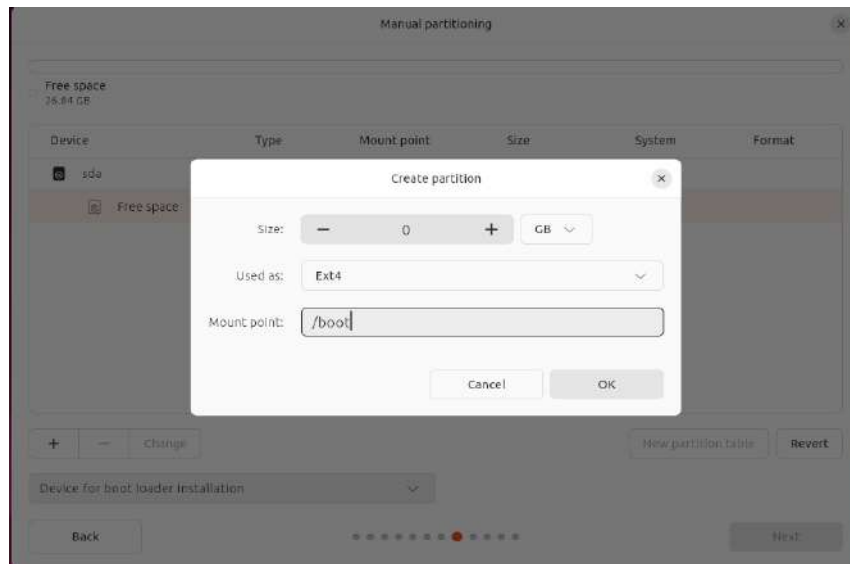

Click on OK and similarly create next partition as / of size 20 GB.

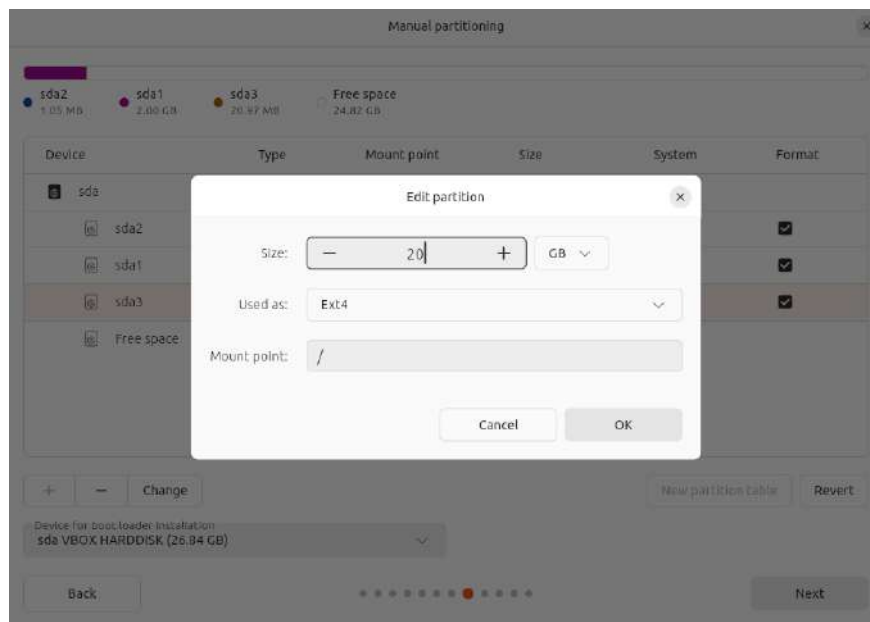

Next, again select the free disk space and create /home partition of size 50 GB.



Click OK.

In the last create swap partition of size 2GB as shown below:

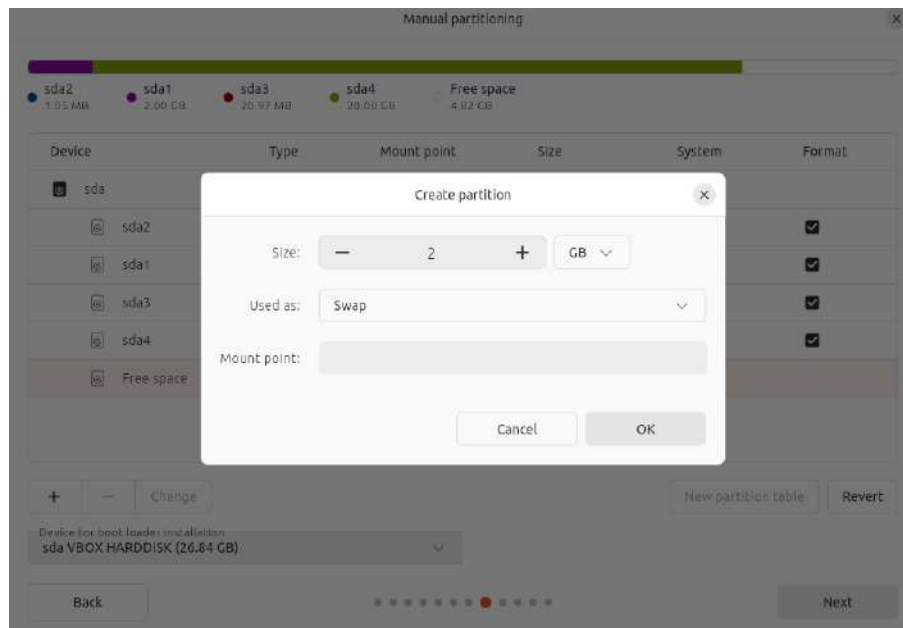

Click OK and then click on Next to proceed further with installation.

Step 12. Create a local user and set your system's hostname, specify the details that suits to your installation.

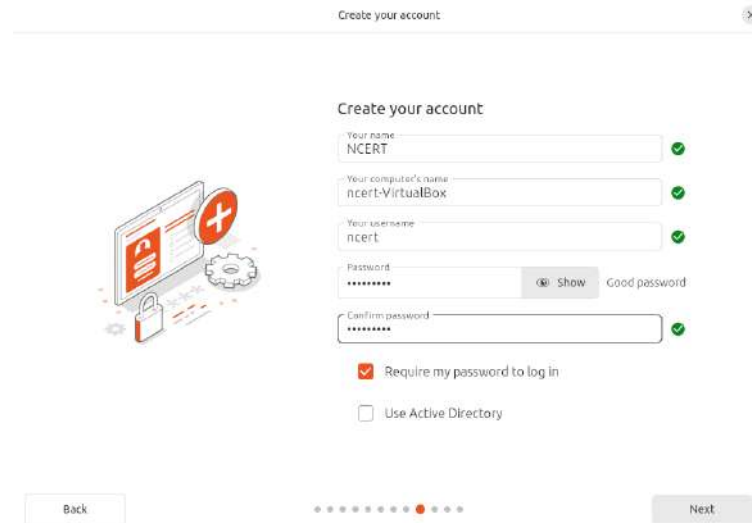

Create your account

Your name
NCERT ✓

Your computer's name
ncert-VirtualBox ✓

Your username
ncert ✓

Password
•••••• Show Good password

Confirm password
•••••• ✓

Require my password to log in

Use Active Directory

Back Next

Click [Next](#)

Step 13. Select Your Location and Time Zone

Choose your preferred location and time zone and then click Next.



Select your timezone

Location: Mumbai Timezone: Asia/Kolkata

Back Next

Step 14. Ready to Start Installation

Review your choices and click on [“Install”](#) option to begin the installation.

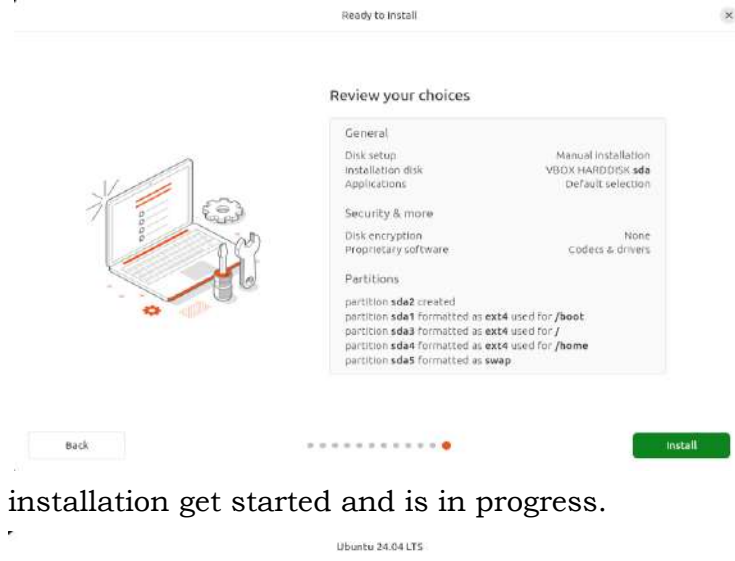

At this point of time installation get started and is in progress.

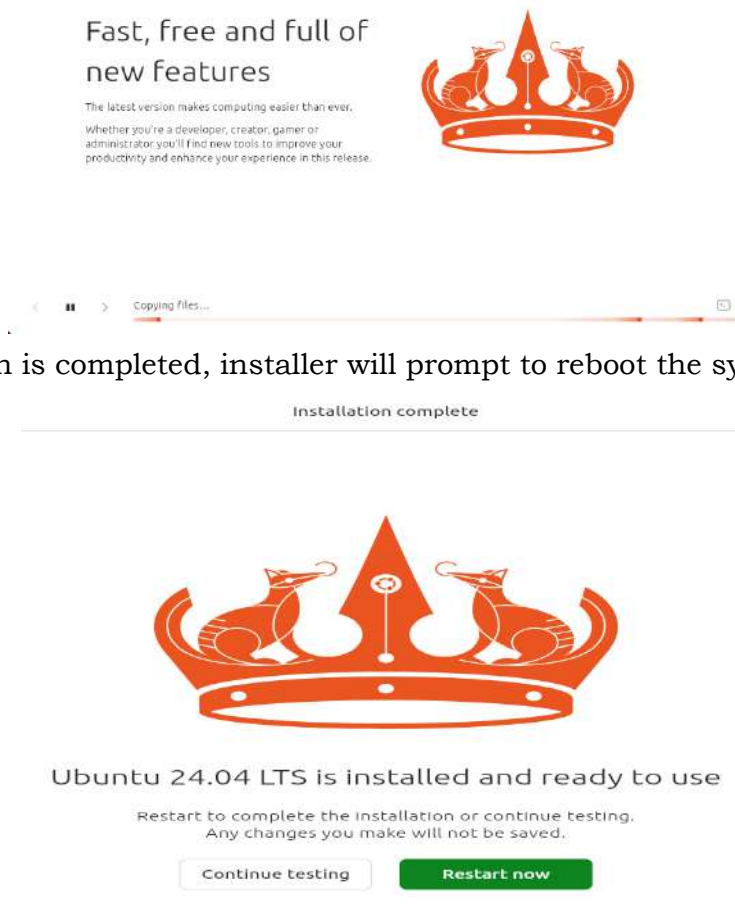

Once the installation is completed, installer will prompt to reboot the system.

Click on [“Restart Now”](#), it will reboot your system and don't forget to remove the installation media and change boot medium from USB to Hard disk from the Bios settings.

Step 15. Login and Desktop Screen Post Installation

When the system boots up after the successful installation, we will get the beneath login screen. Use the same user and its credentials that you have created during the installation.

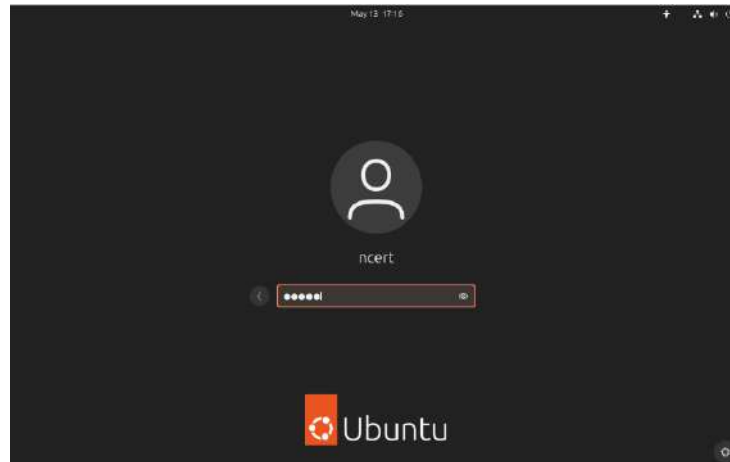

Step 16. After entering the credentials hit enter and this will take to desktop screen. We will get following welcome screen, complete the setup with some additional settings.

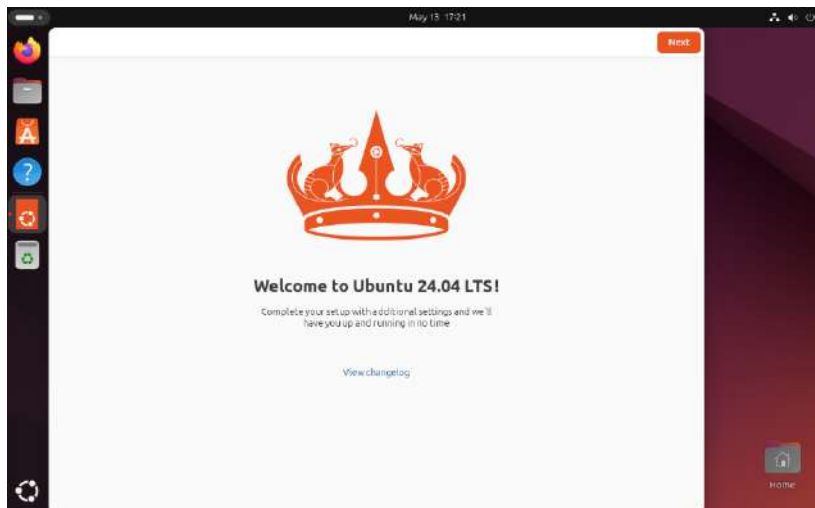

Step 17. Click on [Next](#)

On the following window, disable Ubuntu Pro, choose [“Skip for Now”](#) and click [Next](#)

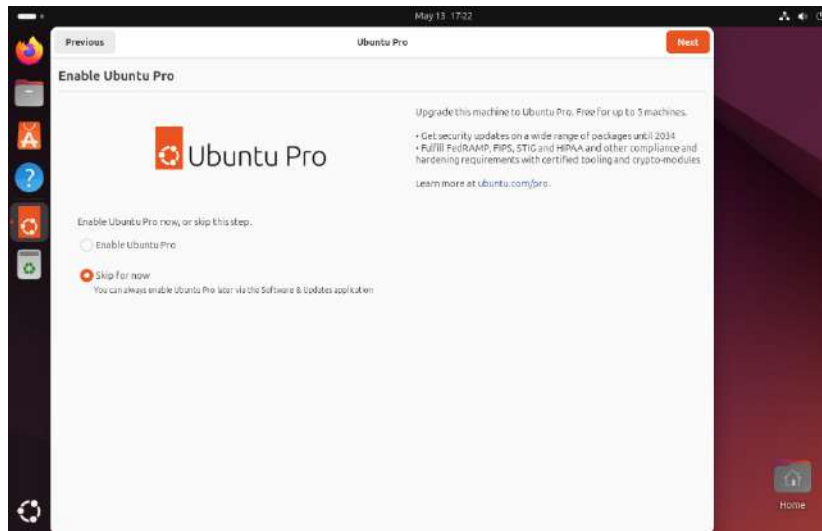

Step 18. Choose “No, don’t share system data”.

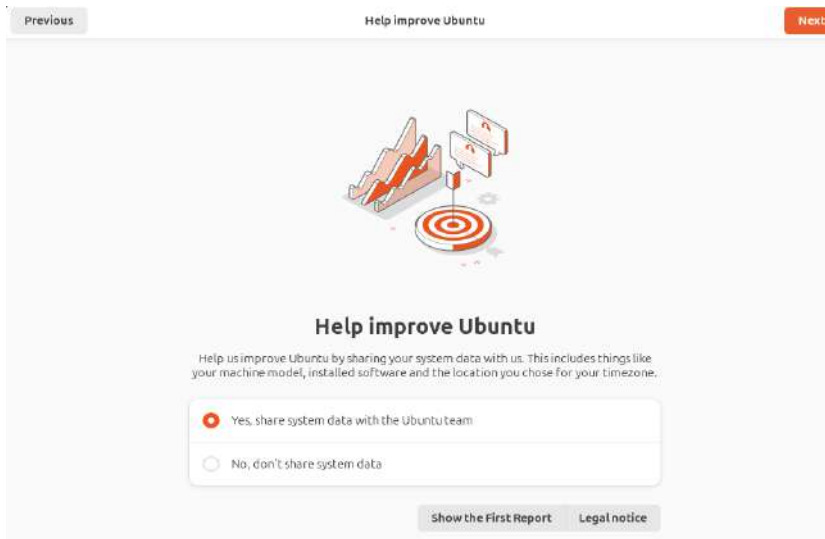

Step 19. Click on Finish to start using your Ubuntu 24.04.

Step 20. *Next*, Open the terminal and install neofetch utility.

```
$ sudo apt update
```

```
$ sudo apt install neofetch -y
```

```
$ neofetch
```

<https://www.linuxtechi.com/install-ubuntu-24-04-step-by-step/>

VirtualBox

Oracle VM VirtualBox is a cross-platform virtualization application developed by Oracle Corporation. It enables users to install and run multiple operating systems on virtual hard disks, including Windows, macOS, Solaris, and Linux.

For instance, you can use VirtualBox to run Windows and Linux on your Mac, Windows Server on your Linux server, or Linux on your Windows PC, all while continuing to use your existing applications.

The primary limitations you may encounter when installing multiple virtual machines are disk space and memory.

VirtualBox Installation

VirtualBox can be downloaded here: [VirtualBox Downloads](#) .

<https://www.virtualbox.org/wiki/Downloads>

Practical Activity: Demonstrate to install Ubuntu Linux on Virtual Box.

Step 1: Before we begin with the installation process, we need to **Download ISO for Ubuntu**. For that, all the versions of Ubuntu are available on the [Official Site](#).

The screenshot shows two download cards for Ubuntu. The top card is for Ubuntu 18.04.3 LTS, with a green 'Download' button. Below it are system requirements: 2 GHz dual core processor or better, 4 GB system memory, 25 GB of free hard drive space, either a DVD drive or a USB port for the installer media, and internet access. The bottom card is for Ubuntu 19.10, also with a green 'Download' button. A link for 'Alternative downloads and torrents' is visible below the 19.10 card.

Step 2: Open [VirtualBox](#) and click on the **New** button.

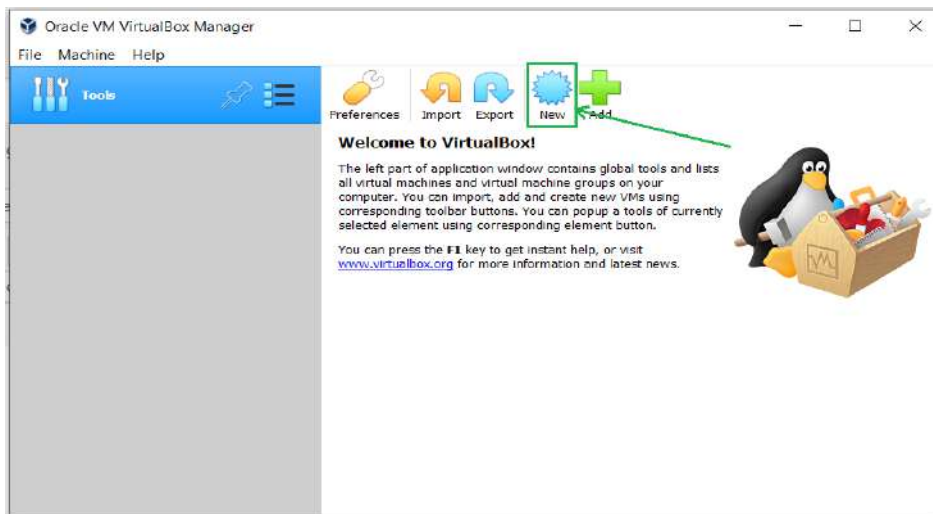

Step 3: Give a **Name** to your **Virtual Machine** and select the **Location** for it to install.

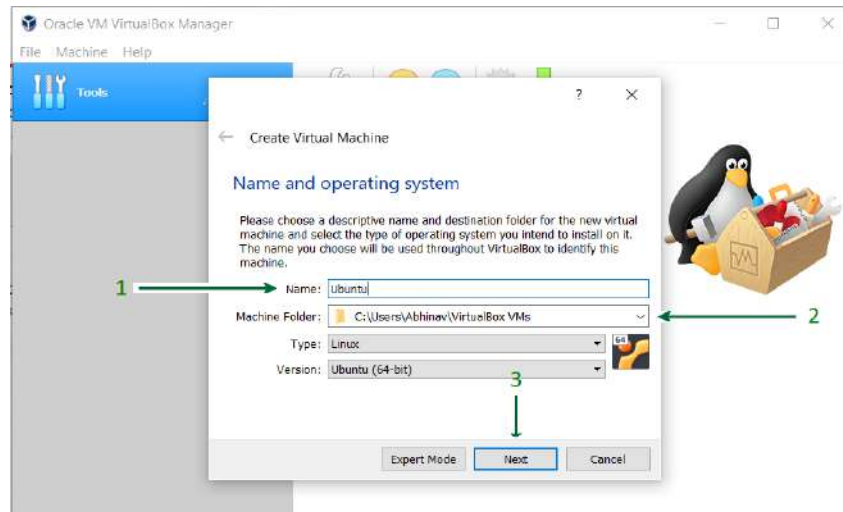

Step 4: Assign **RAM Size** to your Virtual Machine.

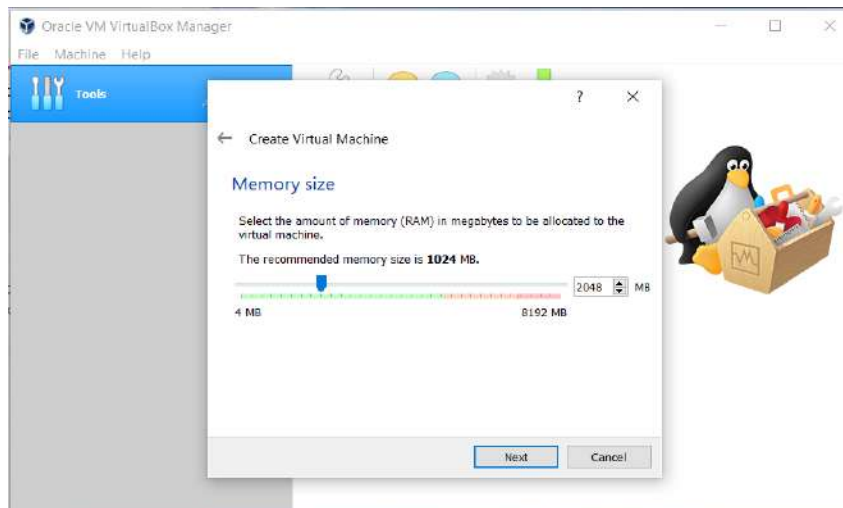

Step 5: Create a **Virtual Hard Disk** for the machine to store files.

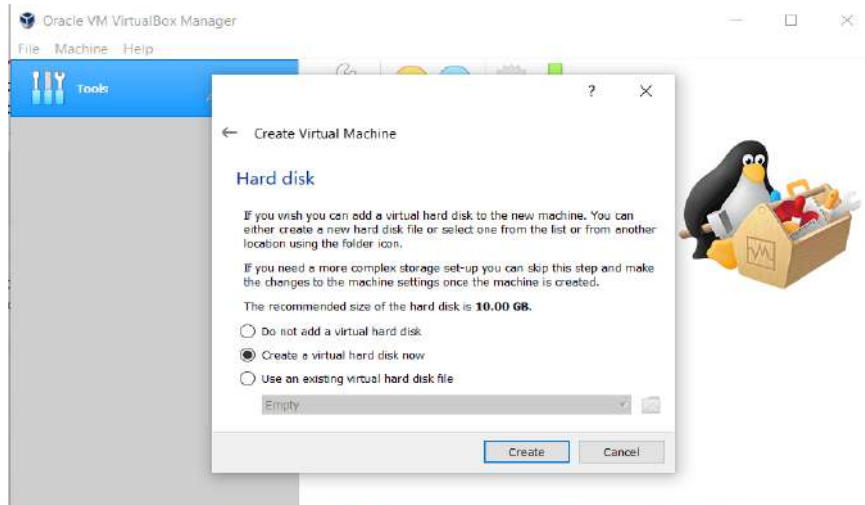

Step 6: Select the type of Hard disk. Using **VDI** type is recommended.

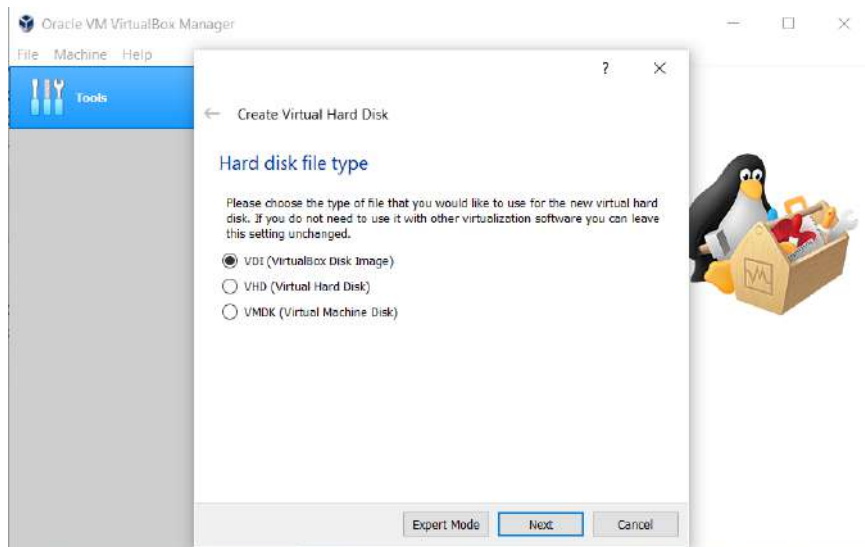

Step 7: Either of the **Physical Storage** types can be selected. Using a **Dynamically Allocated Disk** is by default recommended.

PSSCIVE

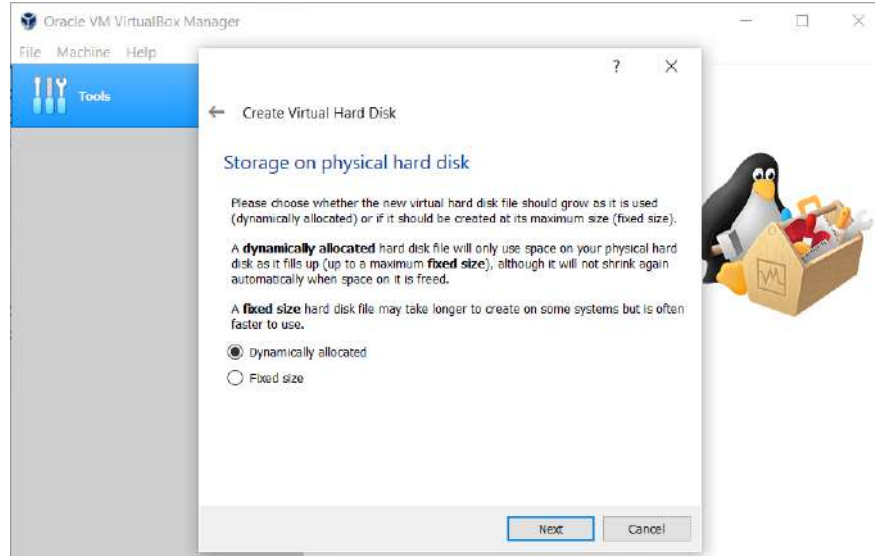

Step 8: Select **Disk Size** and provide the **Destination Folder** to install.

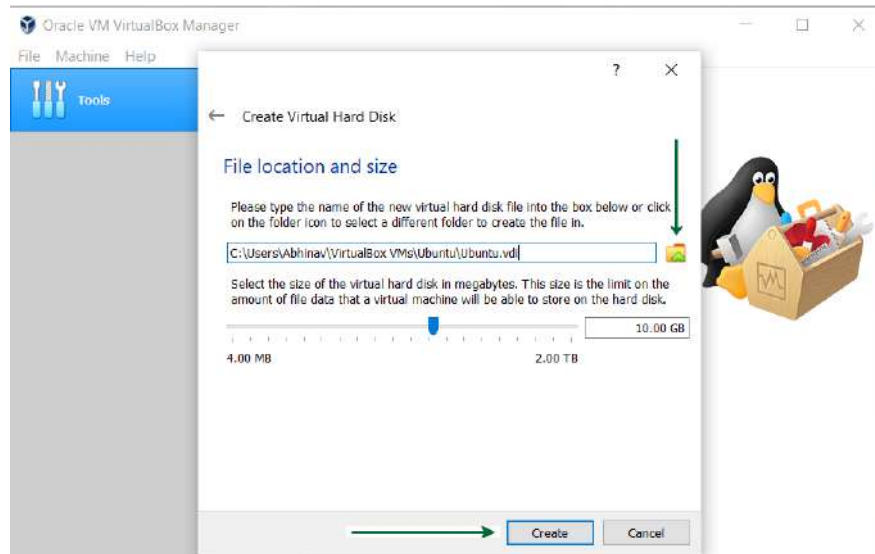

Step 9: After the Disk creation is done, boot the **Virtual Machine** and begin installing [Ubuntu](#).

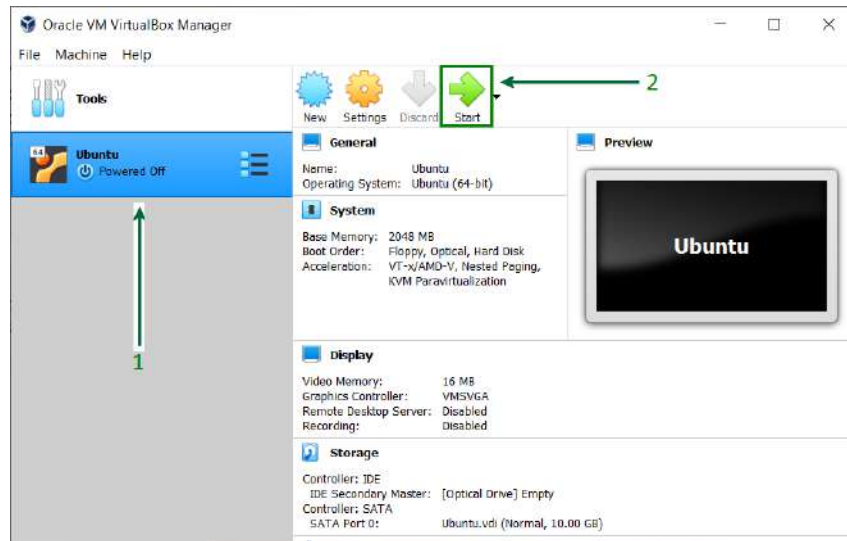

Step 10: If the installation disk is not automatically detected. Browse the file location and select the **ISO file for Ubuntu**.

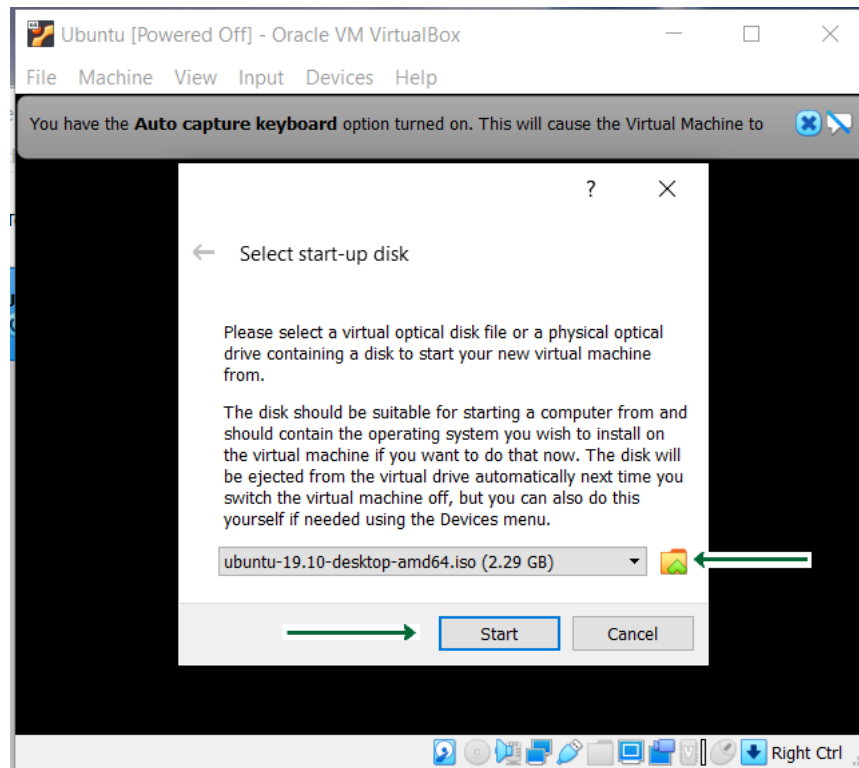

Step 11: Proceed with the installation file and wait for further options.

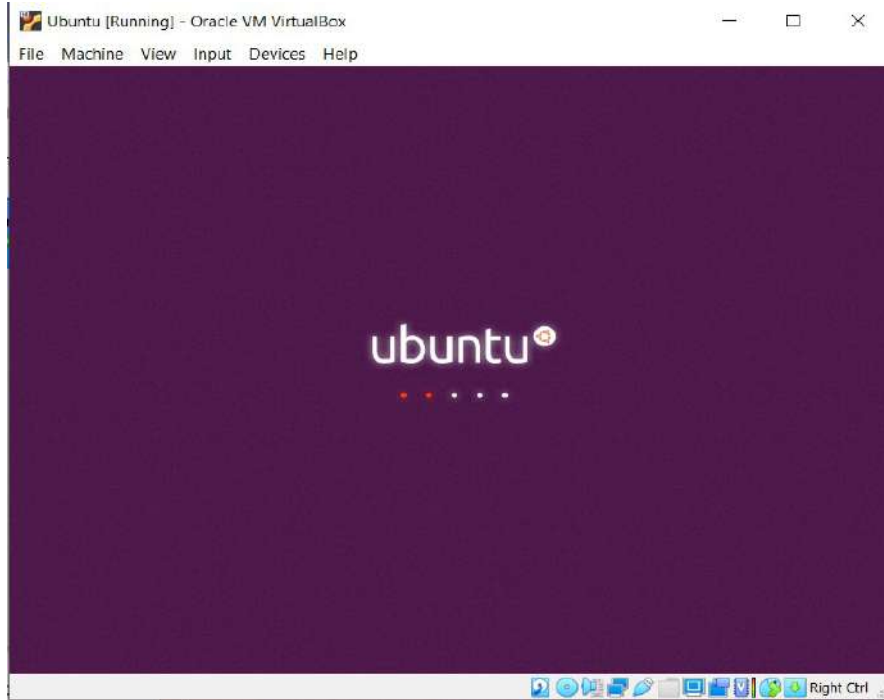

Step 12: Click on the **Install Ubuntu** option, this might look different for other Ubuntu versions.

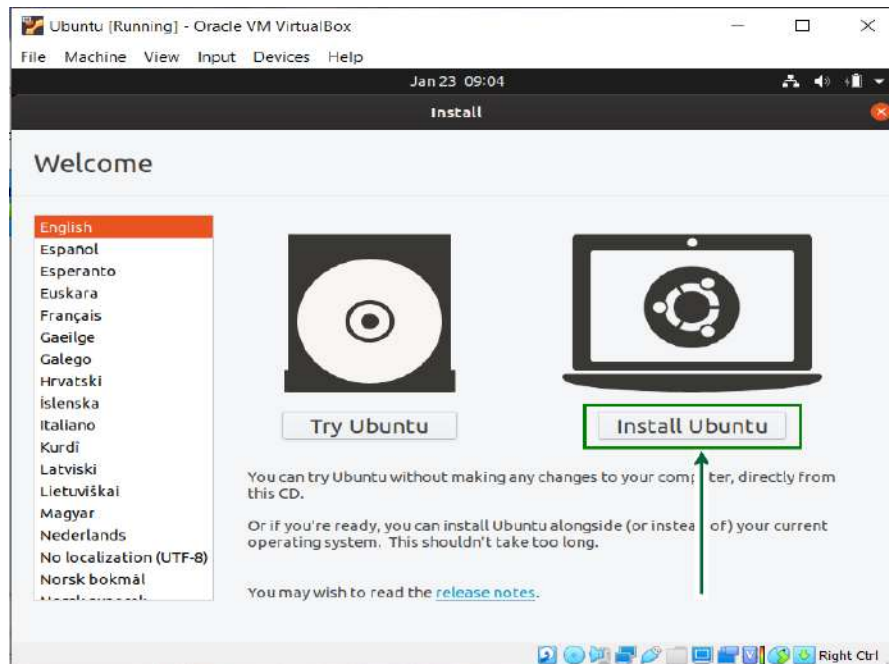

Step 13: Select **Keyboard Layout**, if the defaults are compatible, just click on the **Continue** button and proceed.

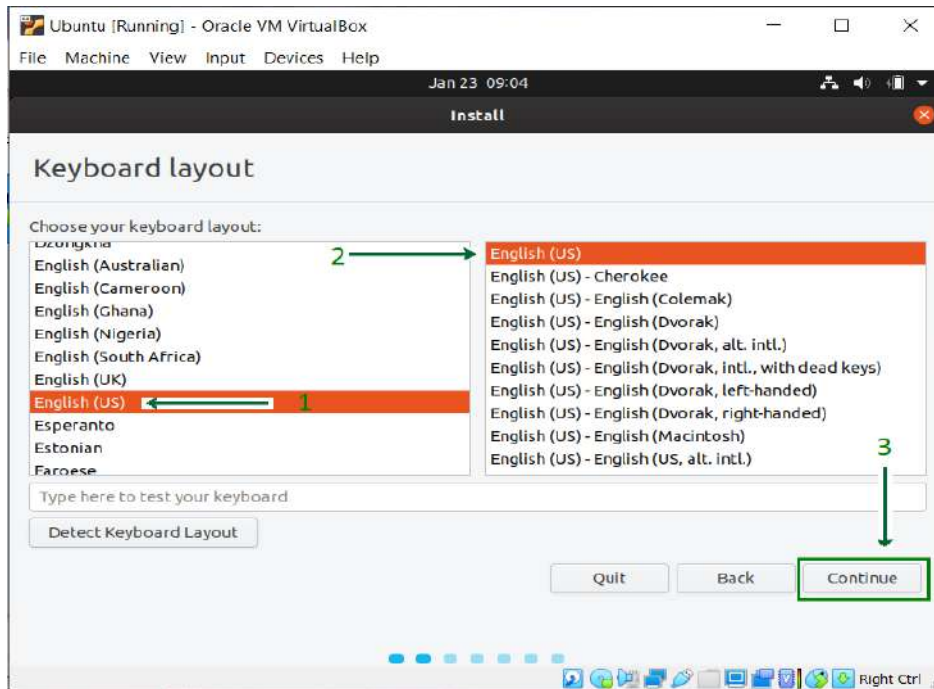

Step 14: Select **Installation Type**. By default, it is set to **Normal Installation**, which is recommended, but it can also be changed to **Minimal Installation** if there is no need for all Ubuntu features.

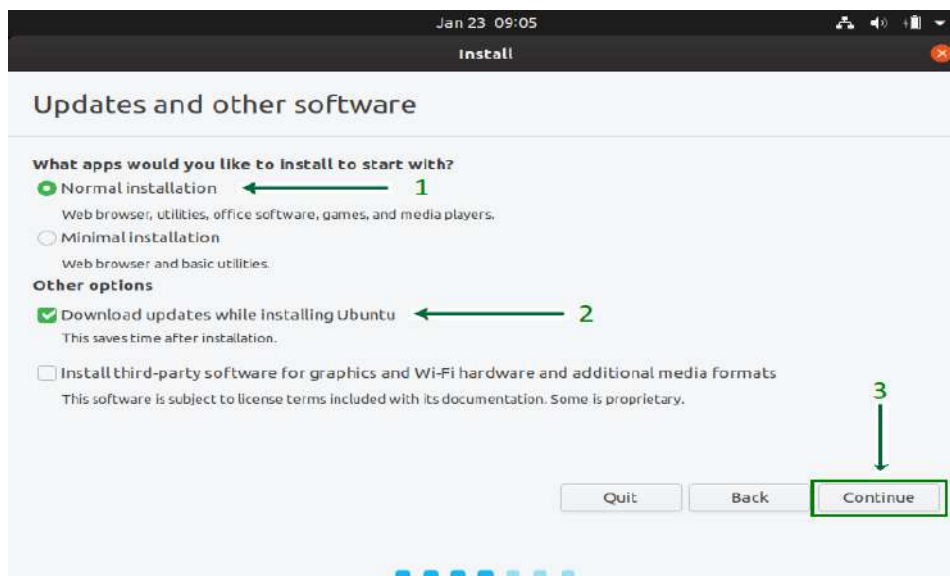

Step 15: Click on the **Install Now** button and carry on with the installation. Do not get worried about the **Erase disk** option, it will only be effective inside the virtual machine, and other system files outside the VirtualBox remain intact.

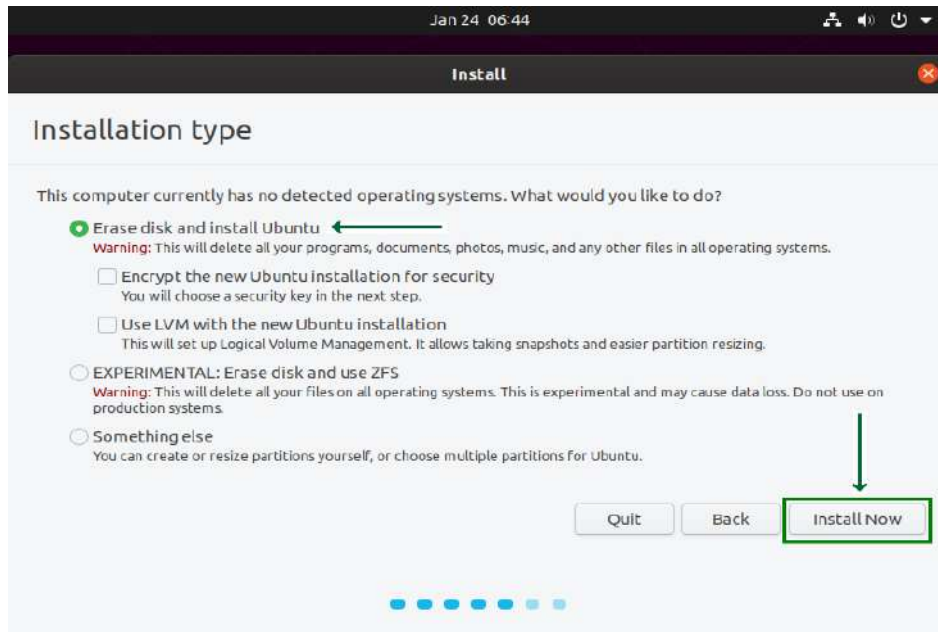

Step 16: Click on the **Continue** button, and proceed with writing changes on the disk.

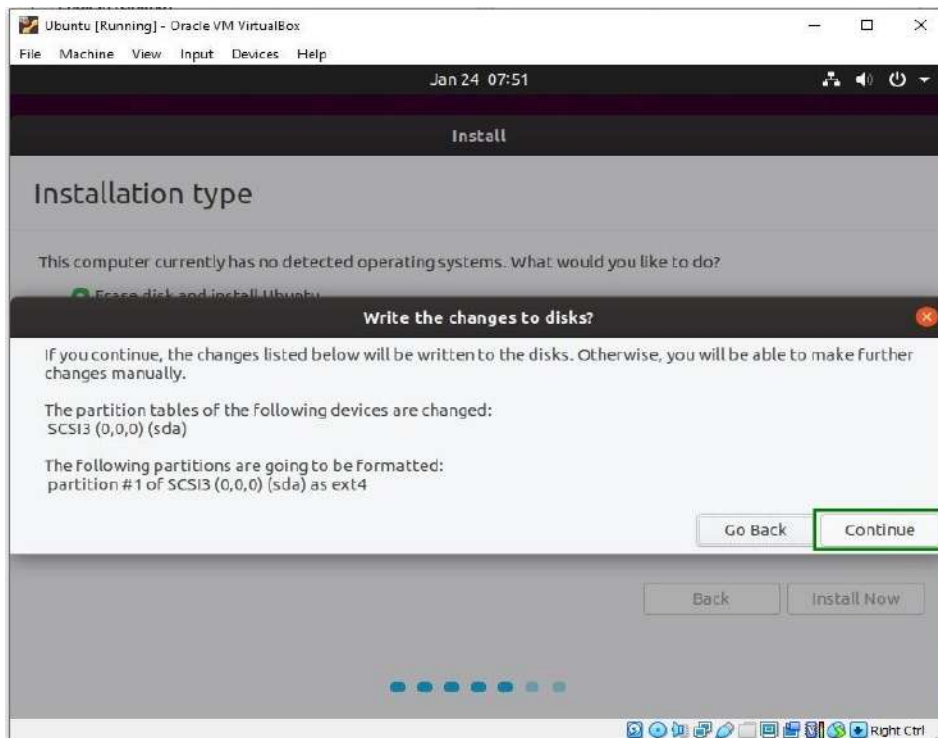

Step 17: Select your Location to set the **Time Zone**.

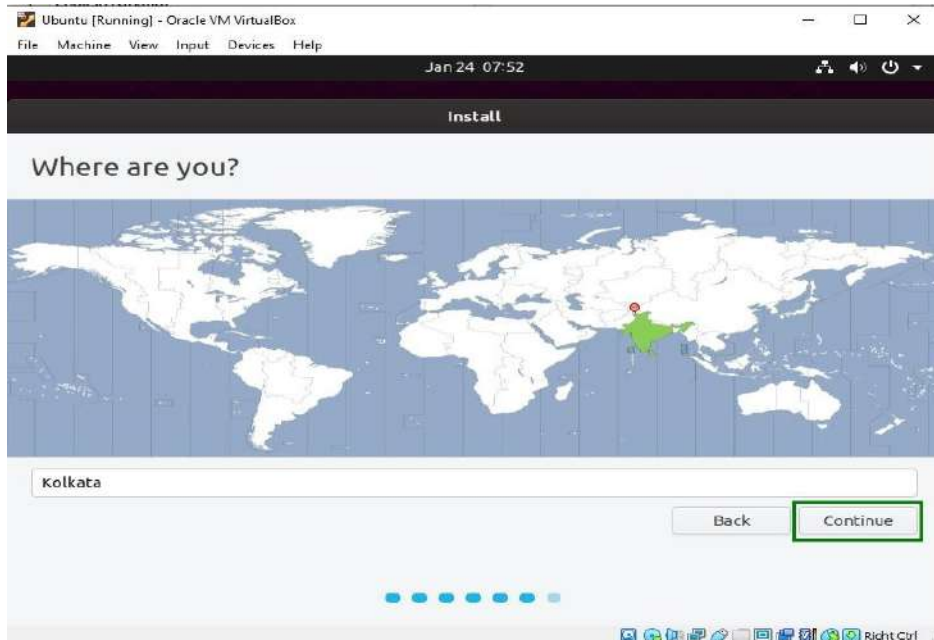

Step 18: Choose a **Name** for your computer and set a **Password** to secure login info.

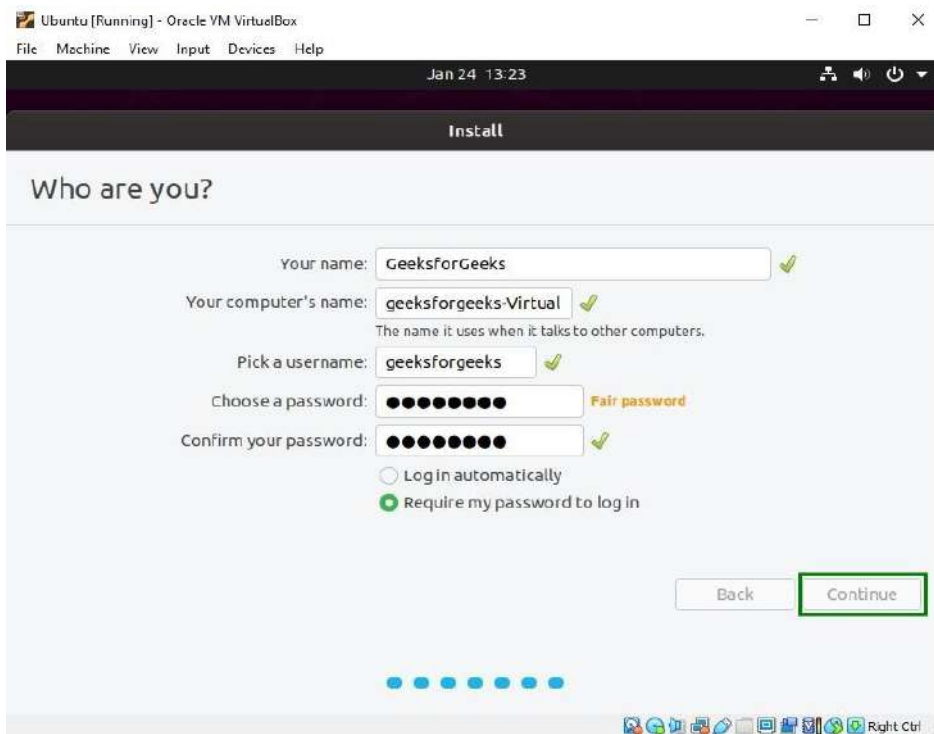

Step 19: Wait for the installation process to complete.

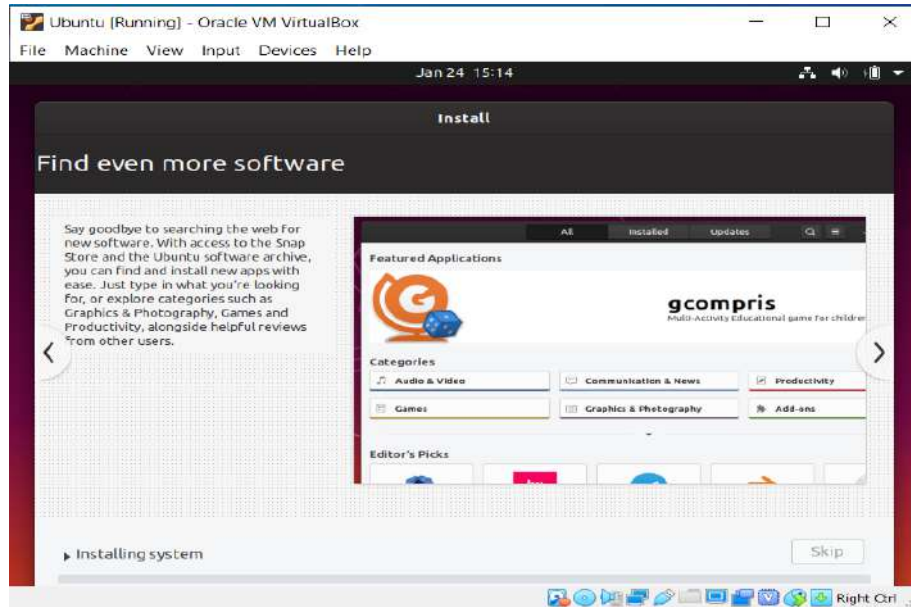

Step 20: Once the installation process is over, reboot your Virtual Machine.

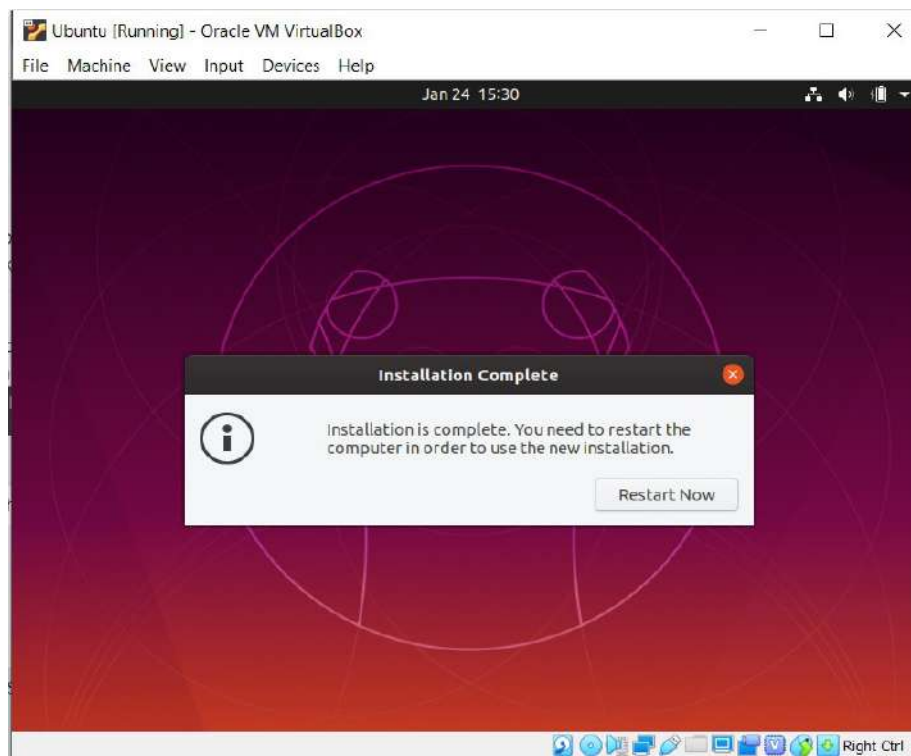

Step 21: Voila!! You're finished with the installation process. Now you can use Ubuntu along with Windows, without creating a dual boot.

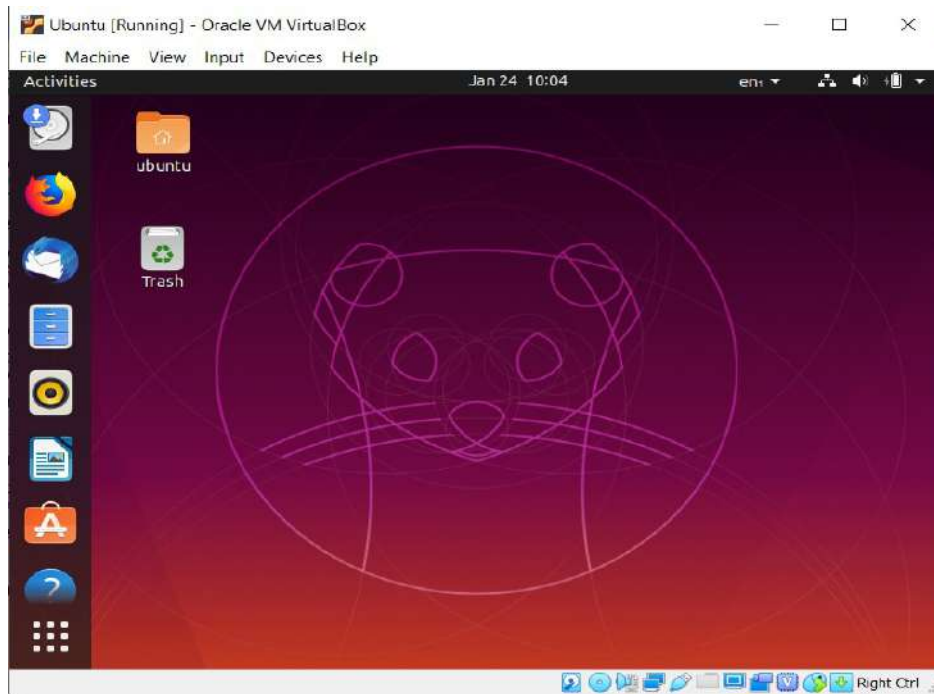

Steps to Make Full Screen of Ubuntu OS on VirtualBox

Note: After installing Ubuntu in Virtual Box, you may find that the Operating System is not suitable for full-screen mode. If you try to make it large by clicking on maximize button, the visual part remains the same and the outside becomes white/black.

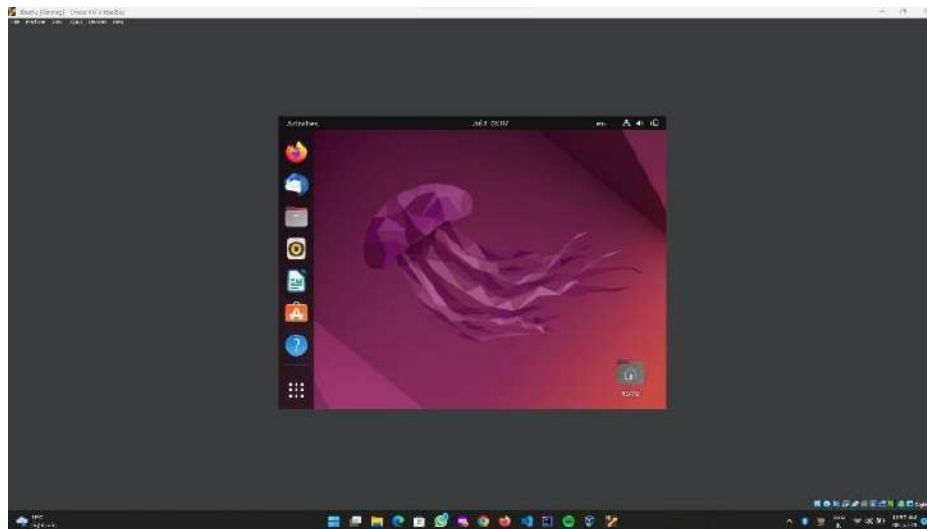

Step 1: To overcome this and make Ubuntu full screen in Virtual Box, click on **Devices** then on **Insert Guest Additions CD Image**.

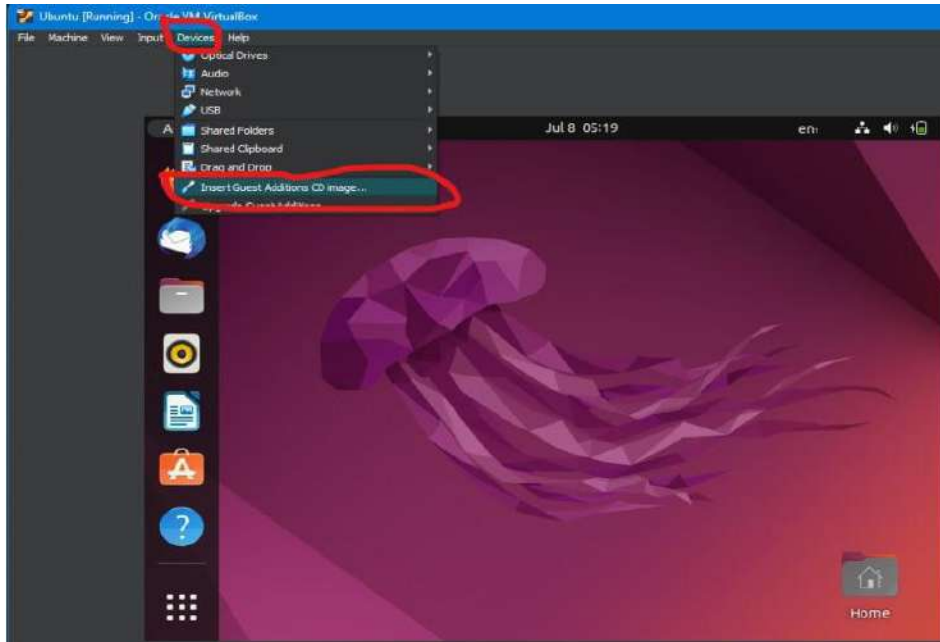

Step 2: Now you will be able to see a **Disk** icon on the **Taskbar**, click on that and it will open the disk

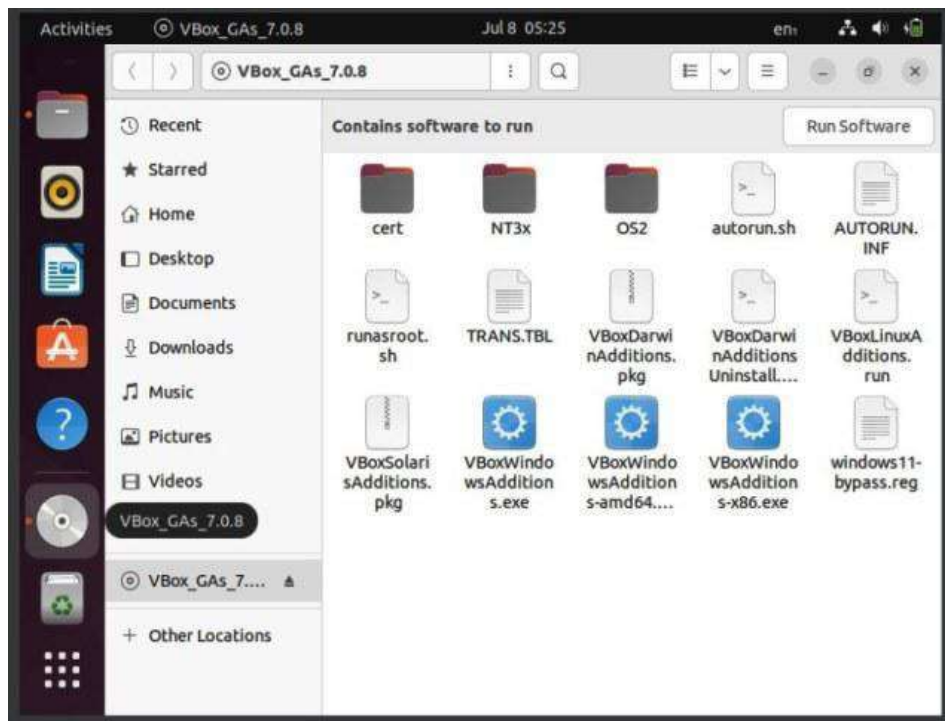

Step 3: Write right-click inside the folder select **Open in the Terminal**, and run the following commands. It will ask for the user's password, enter the password, and wait till

completion.

sudo apt update

sudo apt upgrade

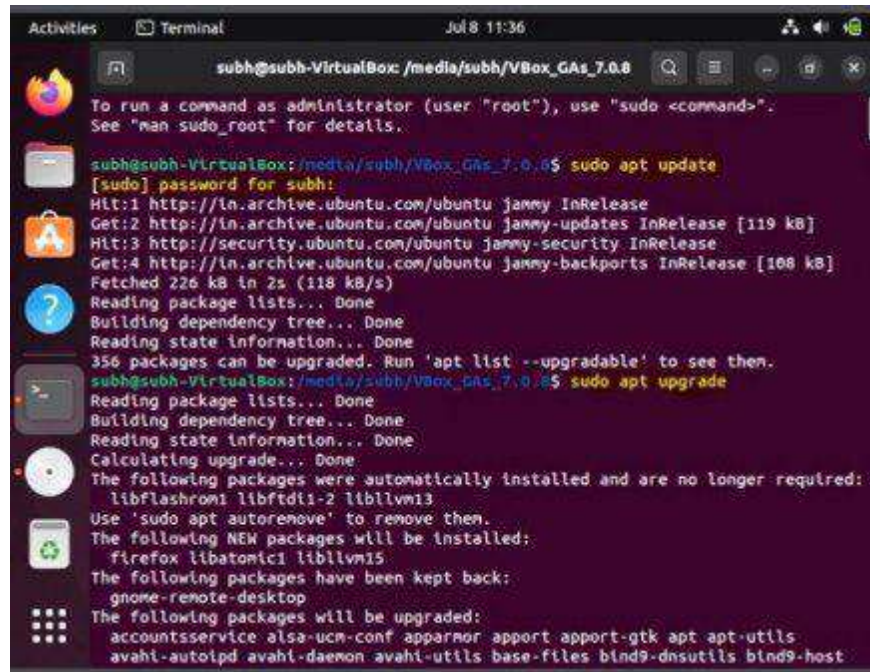

```

subh@subh-VirtualBox: /media/subh/VBox_GAs_7.0.8
To run a command as administrator (user "root"), use "sudo <command>".
See "man sudo_root" for details.

subh@subh-VirtualBox: /media/subh/VBox_GAs_7.0.8$ sudo apt update
[sudo] password for subh:
Hit:1 http://in.archive.ubuntu.com/ubuntu jammy InRelease
Get:2 http://in.archive.ubuntu.com/ubuntu jammy-updates InRelease [119 kB]
Hit:3 http://security.ubuntu.com/ubuntu jammy-security InRelease
Get:4 http://in.archive.ubuntu.com/ubuntu jammy-backports InRelease [108 kB]
Fetched 226 kB in 2s (118 kB/s)
Reading package lists... Done
Building dependency tree... Done
Reading state information... Done
356 packages can be upgraded. Run 'apt list --upgradable' to see them.

subh@subh-VirtualBox: /media/subh/VBox_GAs_7.0.8$ sudo apt upgrade
Reading package lists... Done
Building dependency tree... Done
Reading state information... Done
Calculating upgrade... Done
The following packages were automatically installed and are no longer required:
  libFlashrom1 libftdi1-2 liblilvm13
Use 'sudo apt autoremove' to remove them.
The following NEW packages will be installed:
  firefox libatomic1 liblilvm15
The following packages have been kept back:
  gnome-remote-desktop
The following packages will be upgraded:
  accountsservice alsa-ucm-conf apparmor apport apport-gtk apt apt-utils
  avahi-autoipd avahi-daemon avahi-utils base-files bind9-dnsutils bind9-host

```

Step 4: After updating, run the command `./autorun.sh`

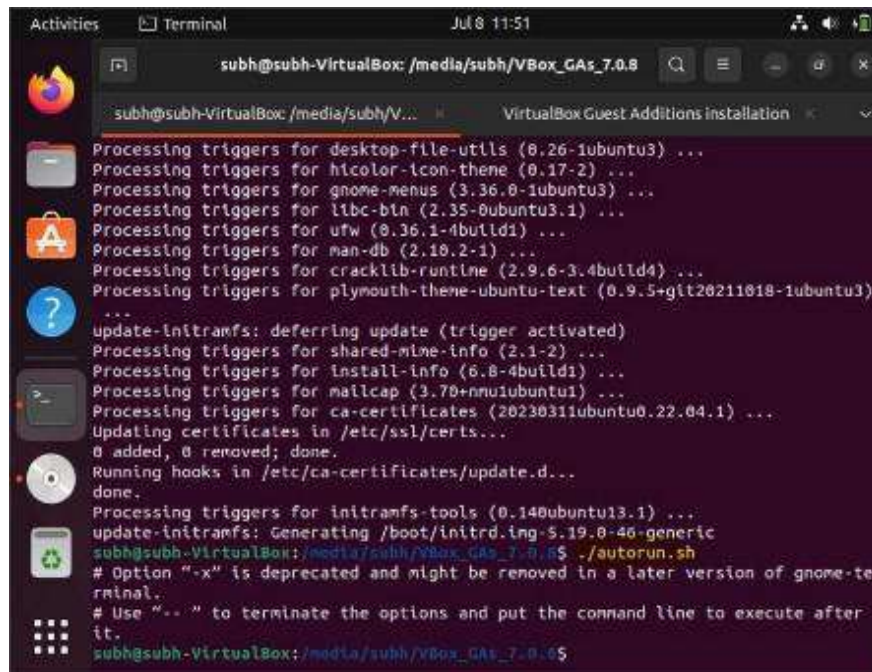

```

subh@subh-VirtualBox: /media/subh/V... VirtualBox Guest Additions installation
Processing triggers for desktop-file-utils (0.26-1ubuntu3) ...
Processing triggers for hicolor-icon-theme (0.17-2) ...
Processing triggers for gnome-menus (3.36.0-1ubuntu3) ...
Processing triggers for libc-bin (2.35-0ubuntu3.1) ...
Processing triggers for ufw (0.36.1-4build1) ...
Processing triggers for man-db (2.10.2-1) ...
Processing triggers for cracklib-runtime (2.9.6-3.4build4) ...
Processing triggers for plymouth-theme-ubuntu-text (0.9.5+git20211018-1ubuntu3)
...
update-initramfs: deferring update (trigger activated)
Processing triggers for shared-mime-info (2.1-2) ...
Processing triggers for install-info (6.8-4build1) ...
Processing triggers for mailcap (3.70+nmu1ubuntu1) ...
Processing triggers for ca-certificates (20230311ubuntu0.22.04.1) ...
Updating certificates in /etc/ssl/certs...
0 added, 0 removed; done.
Running hooks in /etc/ca-certificates/update.d...
done.
Processing triggers for initramfs-tools (0.140ubuntu13.1) ...
update-initramfs: Generating /boot/initrd.img-5.19.0-46-generic
subh@subh-VirtualBox: /media/subh/VBox_GAs_7.0.8$ ./autorun.sh
# Option "-x" is deprecated and might be removed in a later version of gnome-ter
# Use "--" to terminate the options and put the command line to execute after
it.
subh@subh-VirtualBox: /media/subh/VBox_GAs_7.0.8$

```

Step 5: Now it will ask for the password and after checking the password a new tab will open inside the terminal. Enter **Yes** there.

```

subh@subh-VirtualBox: /media/subh/V... VirtualBox Guest Additions Installation
Verifying archive integrity... 100% MD5 checksums are OK. All good.
Uncompressing VirtualBox 7.0.8 Guest Additions for Linux 100%
VirtualBox Guest Additions installer
This system appears to have a version of the VirtualBox Guest Additions
already installed. If it is part of the operating system and kept up-to-date,
there is most likely no need to replace it. If it is not up-to-date, you
should get a notification when you start the system. If you wish to replace
it with this version, please do not continue with this installation now, but
instead remove the current version first, following the instructions for the
operating system.

If your system simply has the remains of a version of the Additions you could
not remove you should probably continue now, and these will be removed during
installation.

Do you wish to continue? [yes or no]
yes
Copying additional installer modules ...
Installing additional modules ...
VirtualBox Guest Additions: Starting.
VirtualBox Guest Additions: Setting up modules
VirtualBox Guest Additions: Building the VirtualBox Guest Additions kernel
modules. This may take a while.
VirtualBox Guest Additions: To build modules for other installed kernels, run
VirtualBox Guest Additions: /sbin/rcvboxadd quicksetup <version>
VirtualBox Guest Additions: or
VirtualBox Guest Additions: /sbin/rcvboxadd quicksetup_all
  
```

Step 6: After installation restart Ubuntu and now you can use Ubuntu in Full-Screen Mode.



So, these are some long steps needed to **Download & Install Ubuntu on VirtualBox**. You should go through the entire steps for successfully **Launching Ubuntu on VirtualBox** in Full- Screen Mode. If you miss any step or perform any error, the **VirtualBox Installation of Ubuntu** will not be successful.

Procedure for installation of Ubuntu Linux in dual booting

Dual booting Linux with Windows is one of the most convenient ways to enjoy both operating systems on the same computer. With dual booting, both OSes are installed on your hard drive, allowing you to choose which one to use each time you power on your system. This setup lets you take full advantage of both operating systems on real hardware.

Compatibility checks

Ensure your system uses UEFI: This tutorial is only applicable for systems with UEFI boot. If your system was purchased in the last 5-6 years, it likely already uses UEFI with a GPT partition. However, it is important to verify that your system uses UEFI. If your system uses legacy BIOS with an MBR partition, please follow this dual boot tutorial instead.

Prerequisites:

To easily and safely install Linux alongside Windows, you will need the following:

- A computer preinstalled with Windows 10.
- A USB drive (at least 4 GB in size) with no data on it.
- An internet connection (to download the Ubuntu ISO image and live USB creation tool). This can be done on any system, not necessarily the one you are dual booting.
- Optional: An external USB disk for backing up your existing data.
- Optional: A Windows recovery or bootable disk (useful for fixing any major boot issues you might encounter).

Activity 2

Practical Activity: 2 Demonstrate to install Ubuntu Linux on Windows computer for dual booting.

Step 1: Make a backup of your Windows system [optional]

It is always nice to have a backup of your data, just in case you mess up with the system while dealing with disk partitions.

I advise copying all the essential data you cannot afford to lose on an external USB disk. You can use an external HDD (slower but cheaper) or SSD (faster but expensive) and copy the important files and folders.

Step 2: Download Ubuntu (or whichever Linux distribution you are using)



Head over to Ubuntu's website and download the ISO file. The file should be around 2.5 GB in size. If you need to download Ubuntu via torrents, you can click the 'alternative

downloads.’

Download Ubuntu ISO Image

Step 3: Create a live USB/disk of Ubuntu

I presume that you are using Windows to create the live USB. Several free applications allow you to create a live Ubuntu USB. You can use any of these tools. Since I cannot show all of them, I'll go with Rufus.

Download Rufus for free from its website. It will download a .exe file.

Download Rufus

Plug in your USB. This device will be formatted so make sure you don't have any important data on this USB disk.

Run the Rufus tool you just downloaded. It automatically identifies the plugged-in USB but double-check it anyway. Now, browse to the location of the downloaded ISO image and ensure that it uses GPT partitioning scheme and UEFI target system.

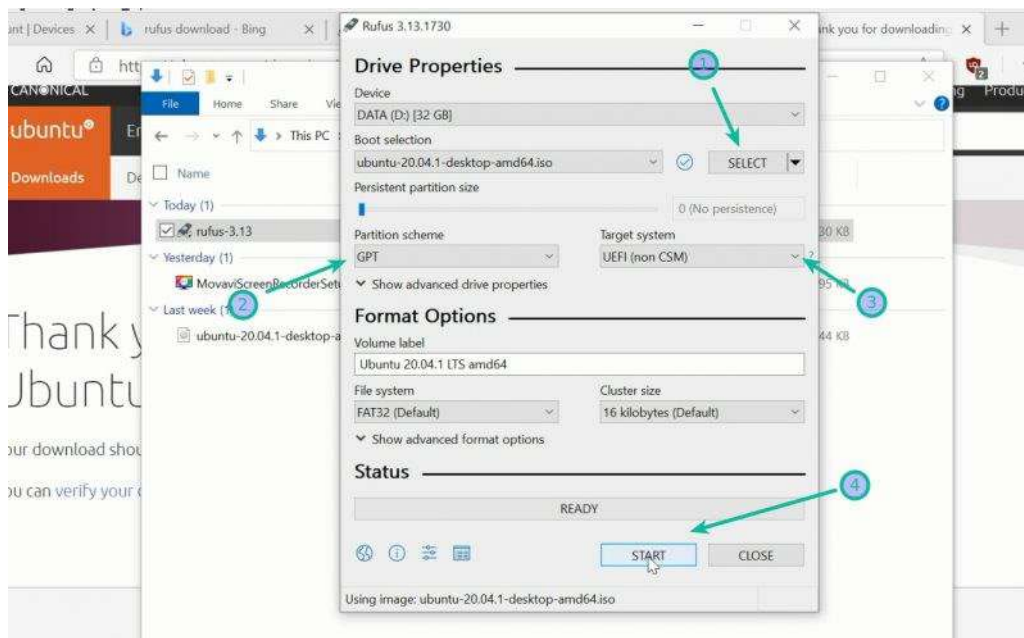

Hit the start button and wait for the process to complete. Your live Linux USB is ready.



Installing Ubuntu and creating the live Ubuntu USB process can be done on any computer. But the rest of the process takes on the system on which you are dual booting.

Step 4: Make some free space on your disk for Ubuntu installation

In many systems, while installing Ubuntu, it gives the option to make a disk partition for Ubuntu. However, that is not a surety. This is why making the required free space on the disk would be better before starting the installation procedure.

In the Windows menu, search for 'disk partitions' and go to 'Create and format hard disk partitions.'

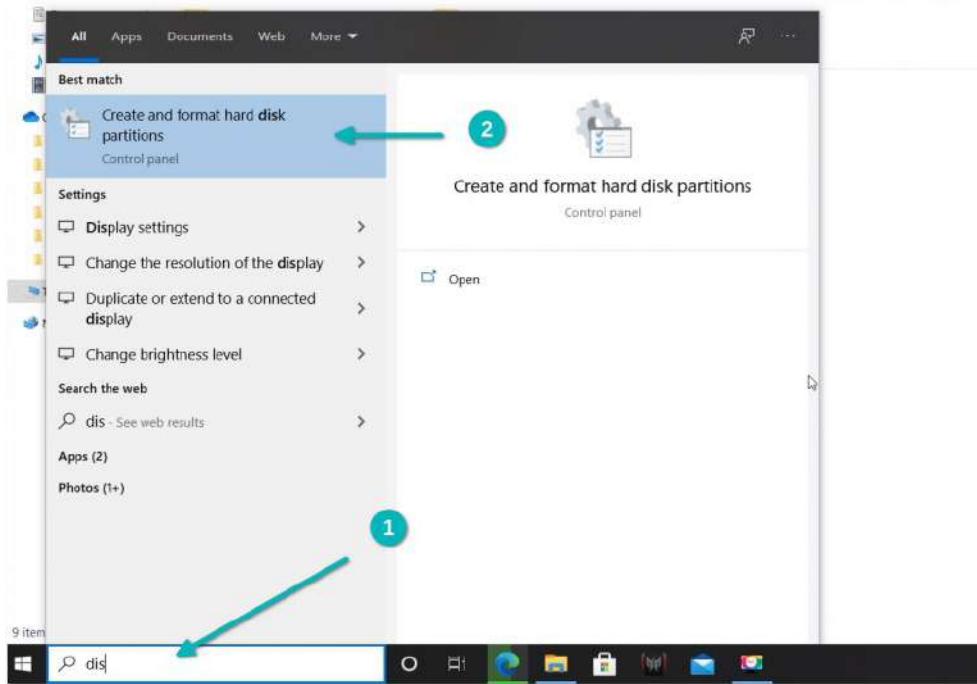

In the Disk Management tool, right-click on the drive which you want to partition and select shrink volume.

If you have just one partition like this, you need to make some free space out of it for Linux. Use any of them except C drive if you have several partitions of considerable size because it may erase the data.

The 256 GB in my system already had several partitions from the manufacturer but mainly for backup and other purposes. The primary partition was the C drive, around 220 GB, where Windows 10 is installed. In my case, I shrunk the C drive to make some free space for Linux installation.

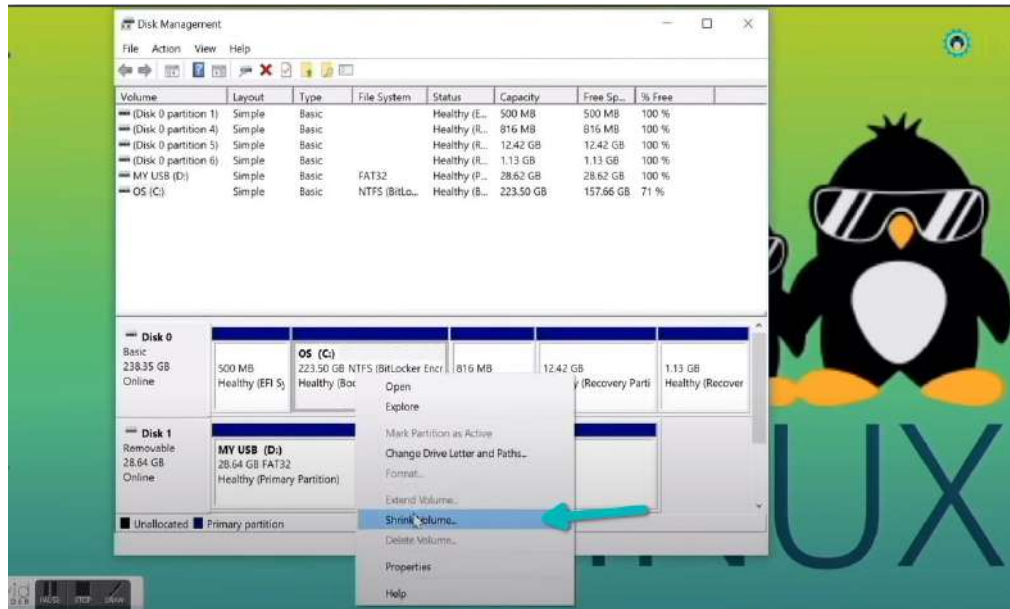

How much space do you need for Linux in dual boot

This depends on how much total disk space you have. You may install Ubuntu on 15 or 20 GB but you'll soon start running out of disk space. These days, you should have at least 120 GB of disk. In that case, go for 30-40 GB of disk for Linux. If you have 250 GB disk, allocate 60-80 GB or even more. If you have more disk space, allocate even more free space, if you want.

What if you have D, E or F drives?

This is a common confusion for many people as they think Ubuntu can only be installed on the C drive. That's not true. I had only one C drive, so I shrank it. If you have D, E or F drive, you may shrink one of those drives. You may also choose to delete the D, E or F drive. NEVER DELETE C DRIVE.

Step 5: Boot from live Ubuntu USB

You created a live Ubuntu USB in step 3. Plug it into the system. Before you go and boot from the live USB, let's have a quick word about the infamous secure boot.

Do I need to disable the secure boot for installing Linux?

6-8 years back, the UEFI secure boot was not well-supported by Linux; hence, you had to disable secure boot before installing Linux. Thankfully, Ubuntu and many other Linux distributions currently support secure boot very well. Usually, you should not need to do anything about it. However, if your system doesn't allow booting from live USB or if you see any other related issue, you may disable the secure boot on Windows.

Alright! Let's see how to boot from the USB. You can go to the boot settings by pressing F2/F10 or F12 at the system start time and selecting to boot from the USB. However, some

people find it difficult.

The longer but an easier step is to access the UEFI boot settings from within Windows. In the Windows menu, search for UEFI and then click on 'Change advanced startup options':

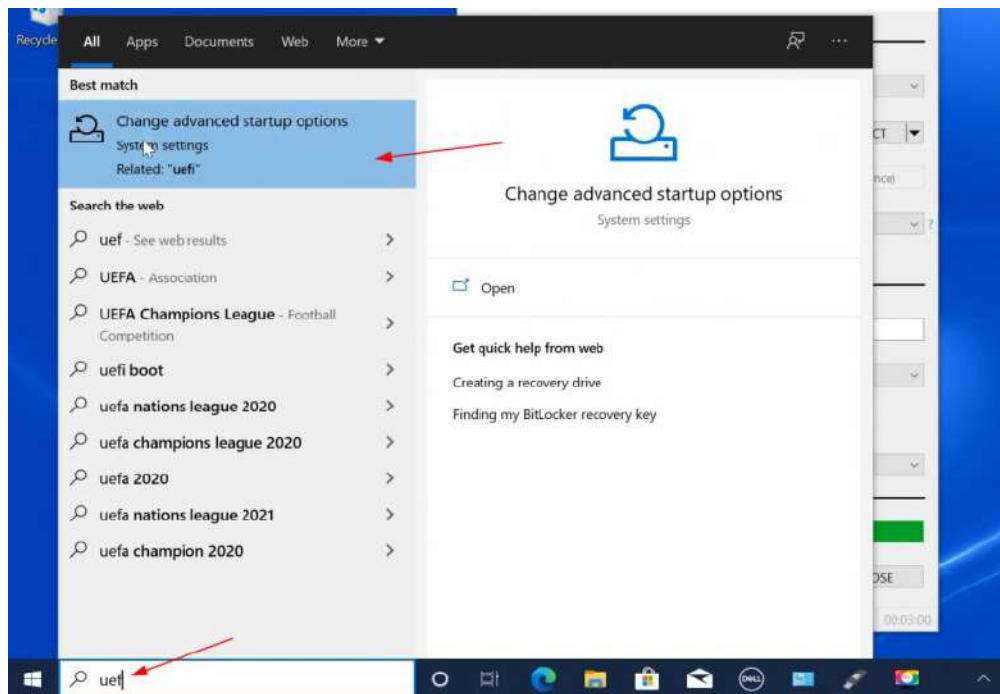

Go to the Advanced startup option and click on Restart now button.

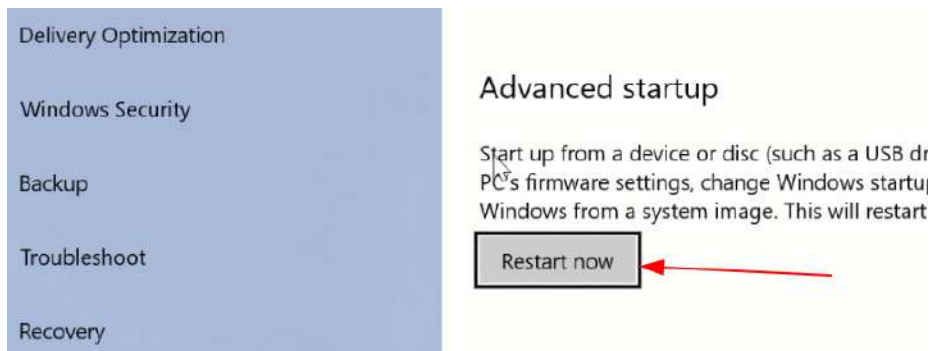

On the next screen, click on 'Use a device':

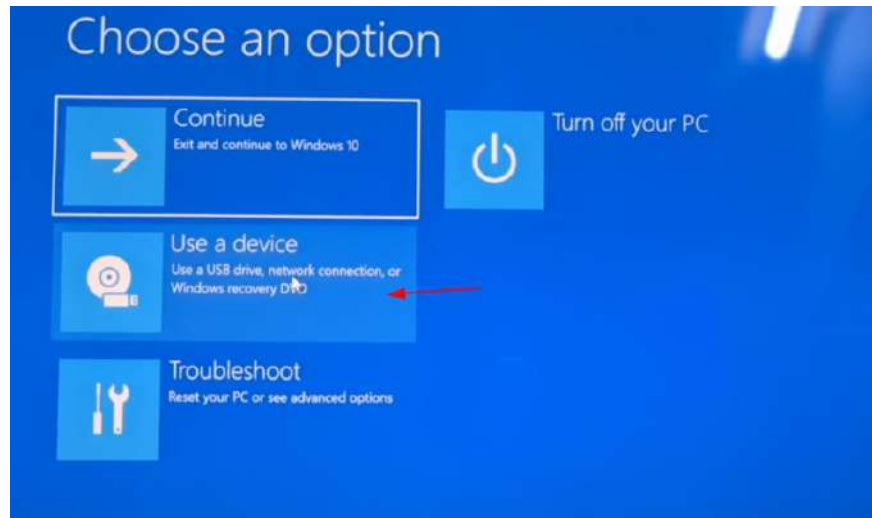

Recognize the USB disk with its name and size. It may also be displayed as EFI USB Device.

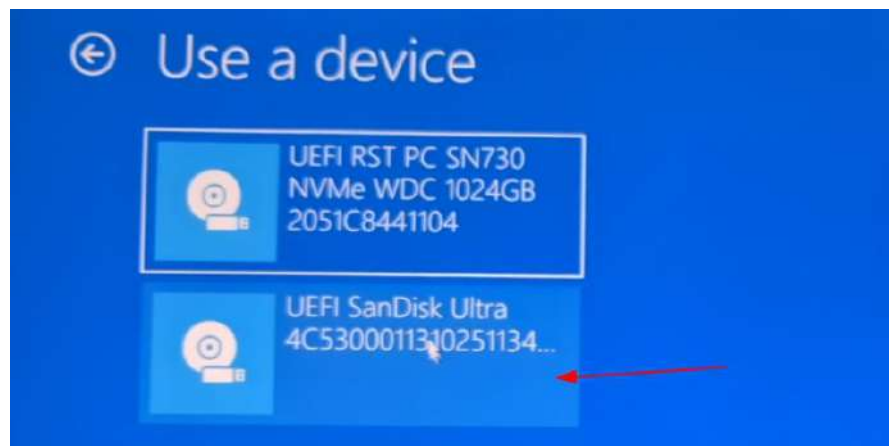

Now it will power off your system and reboot into the disk you chose which should be the live USB disk. You should see a screen like this after a few seconds:

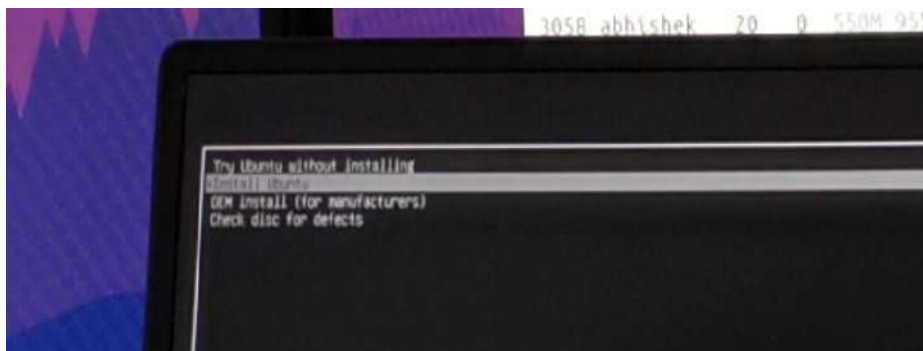

The 'Try Ubuntu without installing' option allows you to experience Ubuntu from the live disk. The option to install Ubuntu can be found on the desktop.

The “Install Ubuntu” option will start the Ubuntu installation immediately. You can opt for either option based on your preference.

Step 6: Installing Ubuntu along with Windows 10

Start the installation procedure. The first few steps are simple. You choose the language and keyboard layout.

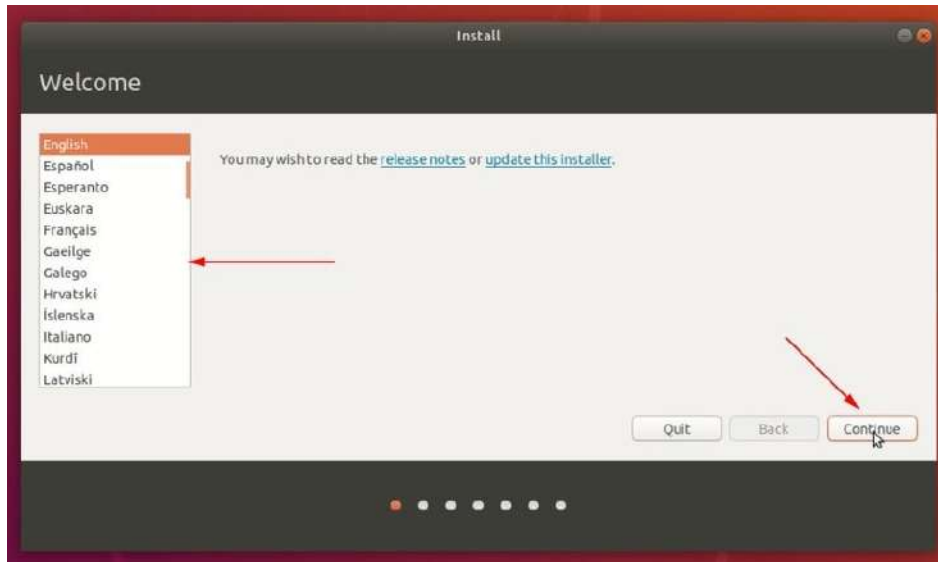

Choose your language / Choose keyboard layout

On the next screen, choose Normal installation. No need to download updates or install third-party software just yet. You may do it after the installation completes.

Hit continue. It may take some time to go to the next step.

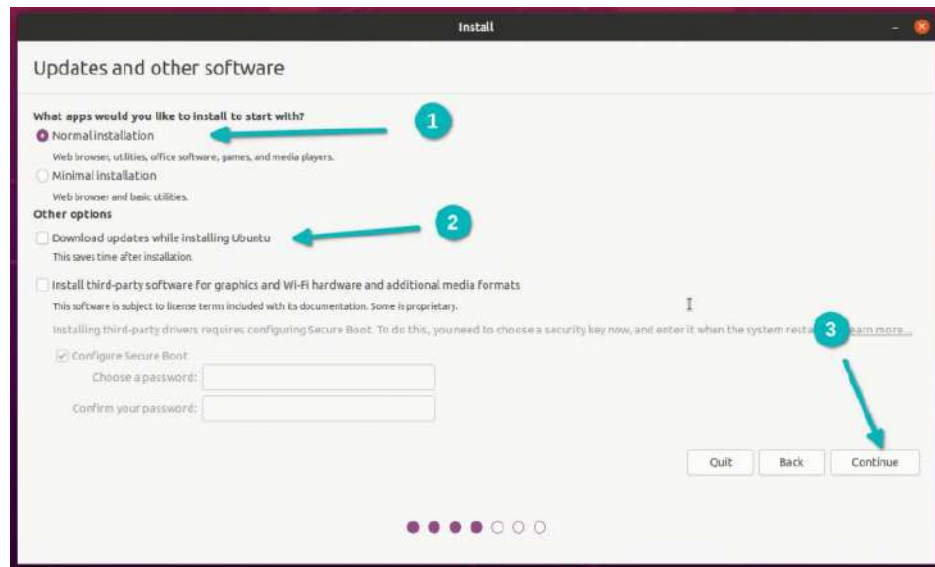

Note: Some people try to download updates and install media codes while installing. In my experience, it sometimes creates issues during installation and may also cause the installation to fail. For this reason, I advise against them.

Important: Installation takes two approaches based on what you see on the next screen

Since this is a detailed tutorial, I'll cover both aspects.

Approach 1: You see the “Install Ubuntu alongside Windows Boot Manager”

If you see the “Install Ubuntu alongside Windows Boot Manager” on the Installation type screen, you can select this method and hit continue.

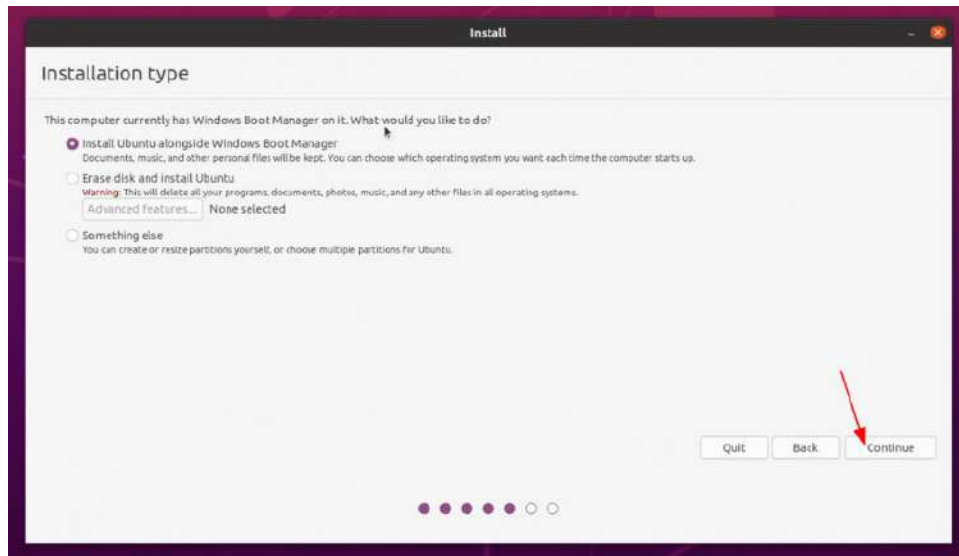

If you see the “Install Ubuntu alongside Windows Boot Manager”, choose it

The next screen will give you the option to create a partition for Ubuntu by dragging the divider. You can allocate appropriate disk space to Linux here. Ubuntu will create one partition of the allocated disk space and it will have root with home and a swap file of 2 GB in size under root itself.

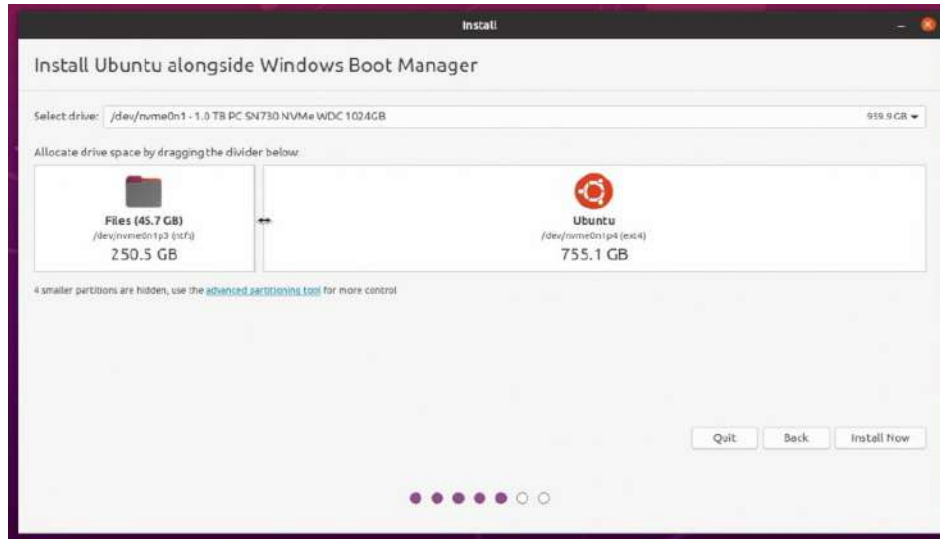

Approach 2: You don't see 'Install Ubuntu alongside Windows Boot Manager' option or it is greyed out, But if you are one of the unlucky ones who don't see this option, no need to worry. Things are not that bad for you. You can still install Ubuntu with Windows.

On the Installation type screen, go with Something Else.

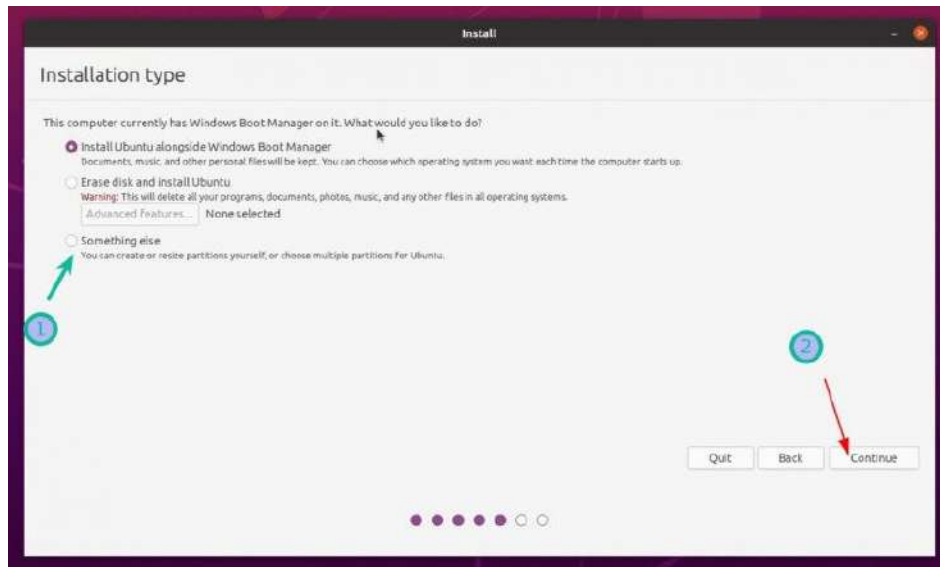

It will take you to the partitioning screen. Remember you had created some free space beforehand?

You may allocate the entire free space to root (swapfile and home will be created automatically under root) or separate root, swap and home partitioning. Both methods are acceptable.

I show the steps for creating root, swap and home partitions separately. But feel free to use

a single partition for all of them.

Select the free space and click on the + sign.

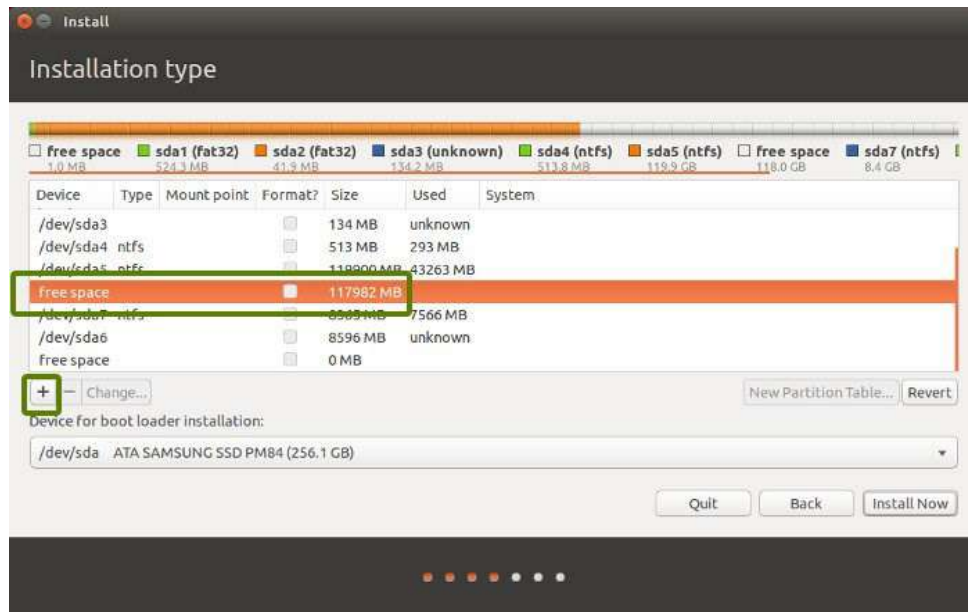

It will provide you with the option to create a Linux partition. You are creating the Root partition. Anything above 25 GB is more than sufficient for it. Choose the size, select Ext 4 as the file type and / (means root) as the mount point.

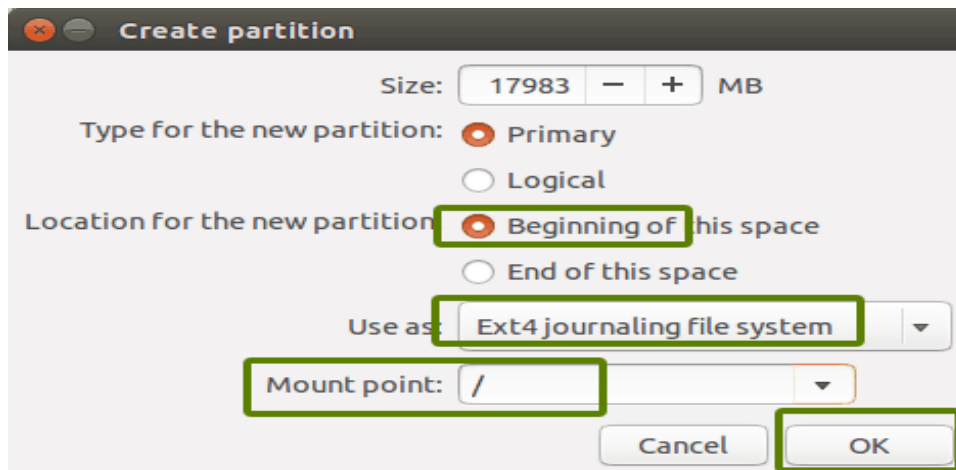

Clicking on OK in the previous step will bring you to the partition screen. Next, create a swap. Like previously, click on the + sign again. This time, use the file type as the Swap area.

[Ideal swap size in Linux](#) is debatable. If you have 2 GB or less RAM, use swap double the size of RAM. If you have 3-6 GB of RAM, use a swap of the same size as RAM. If you have 8 GB or more RAM, you may use swap half the size of RAM (unless you have plenty of disk

space, and you want to use hibernation and in that case, use a swap of at least the same size as RAM).

If you feel like you have less swap on your system, don't worry. You can [easily create swapfile and add more swap space to your systems](#).

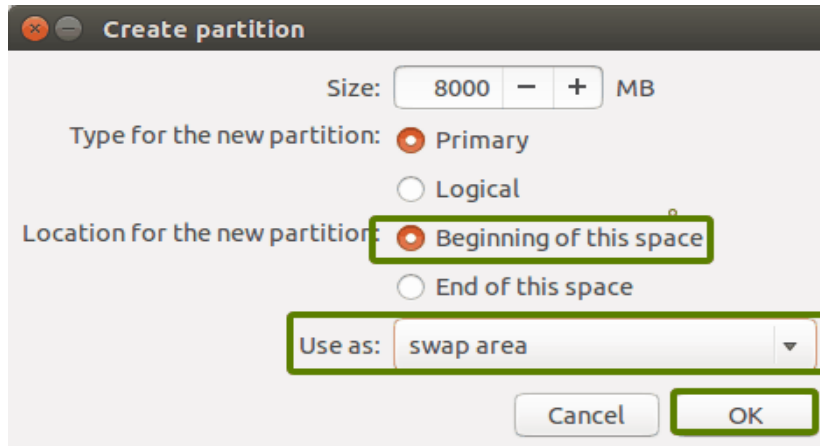

Similarly, create a Home partition. Allocate it maximum space (in fact allocate it the rest of the free space) because this is where you'll save music, pictures and downloaded files.

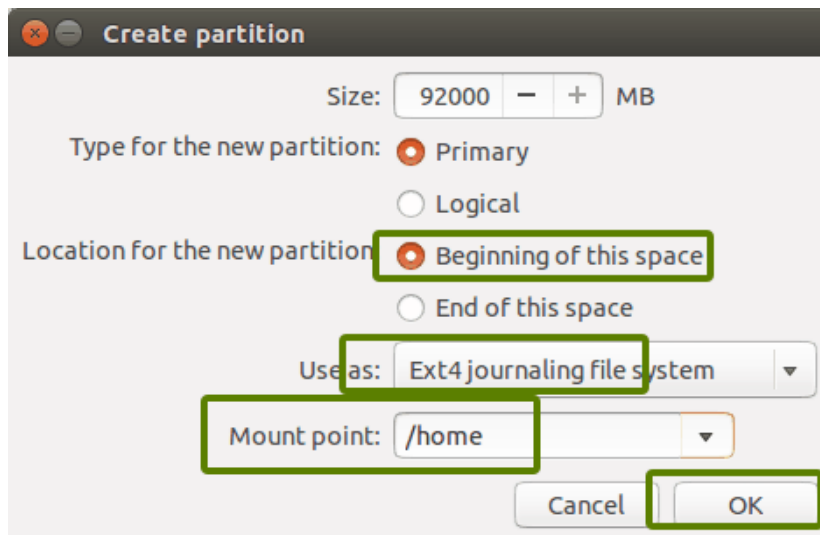

Once you are ready with Root, Swap and Home, click on Install Now:

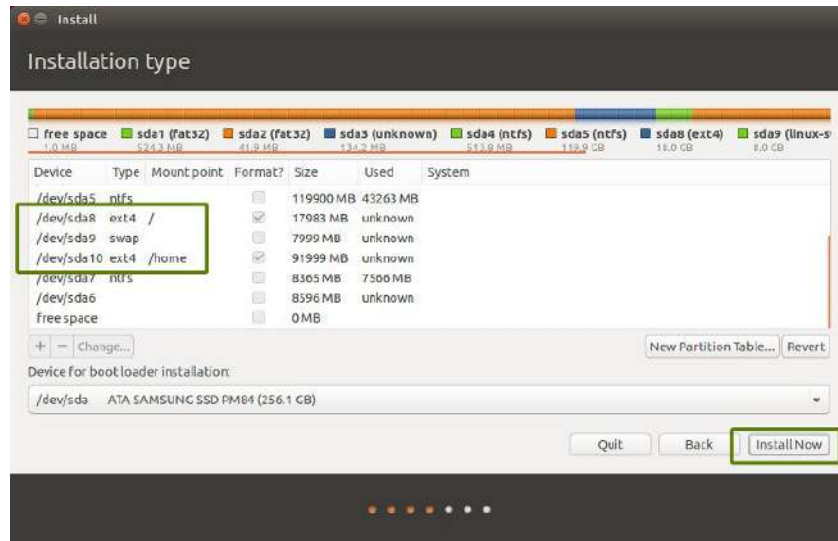

Well, you have almost won the battle. You can smell victory now. Select a timezone when asked.

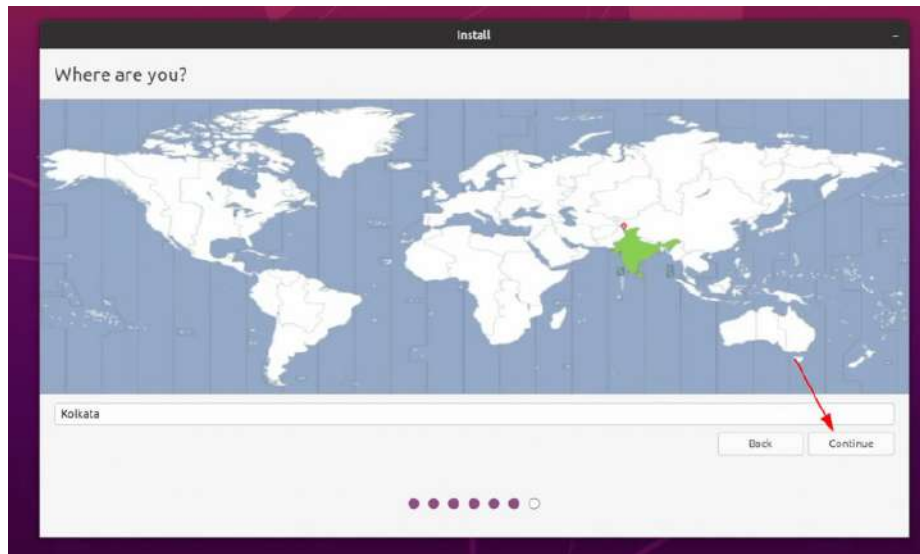

Next, you'll be asked to enter a username, hostname (computer's name) and password.

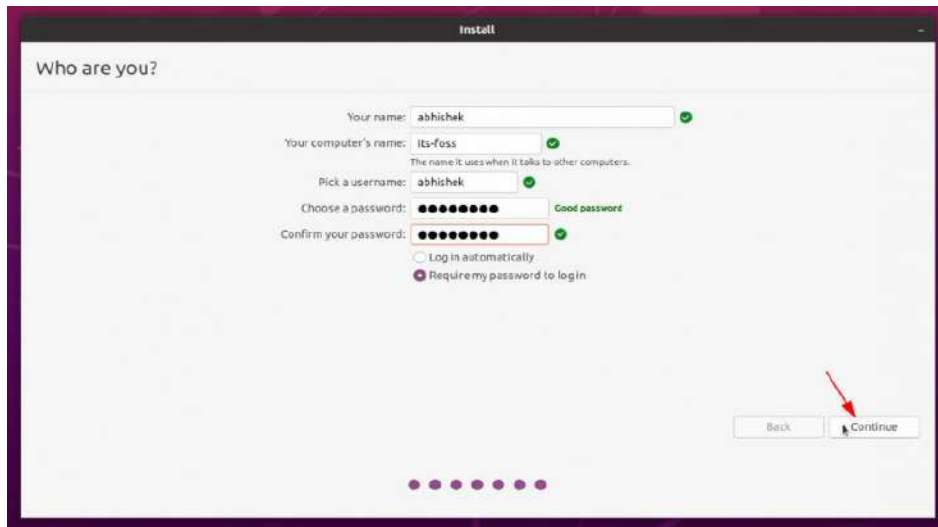

Now it's just a matter of waiting. It should take 8-10 minutes to complete the installation.

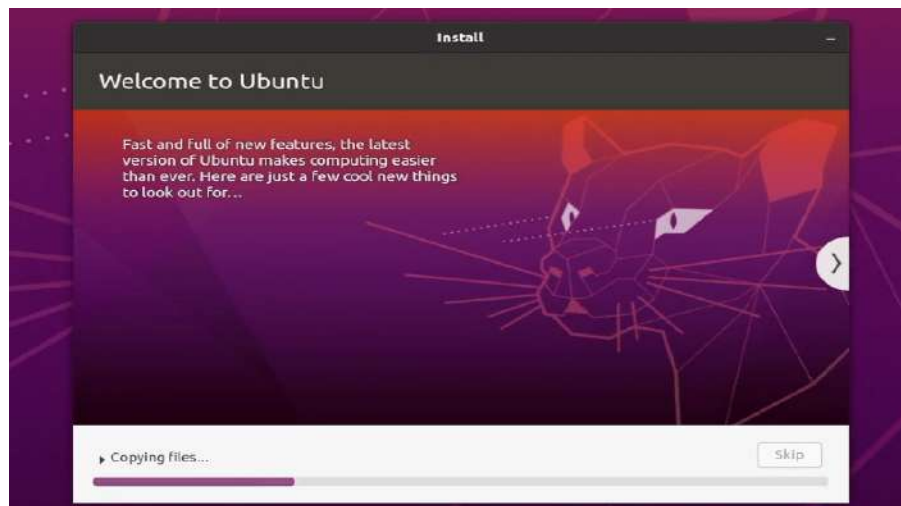

Once the installation finishes, restart the system.

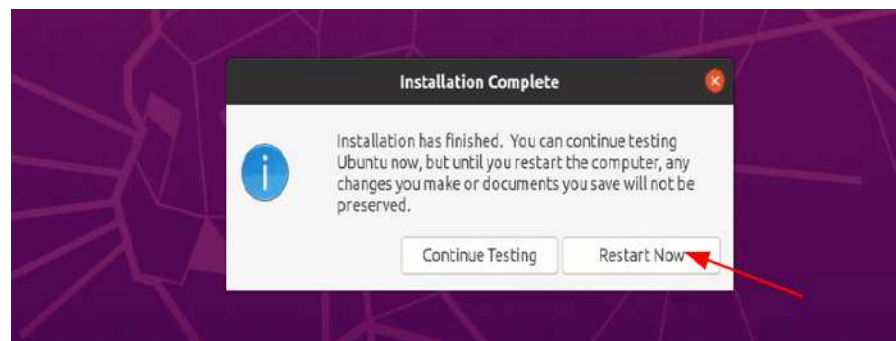

Restart after installation completes

You'll be asked to remove the USB disk. You can remove the disk at this stage without

worrying. The system reboots after this.

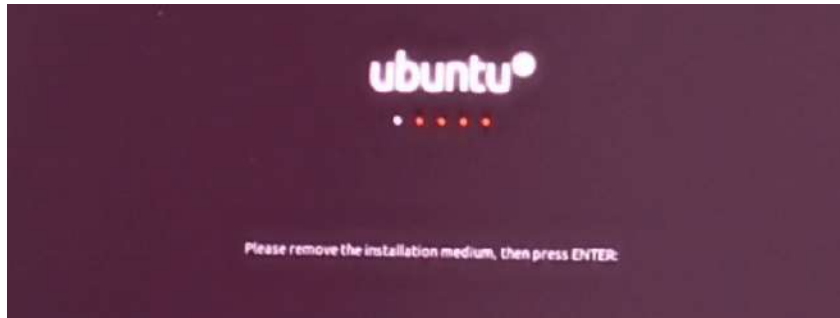

Remove USB and press enter

You do not need the live USB disk to use Linux anymore. You have installed Ubuntu on your computer's disk. Remove the USB and keep it for later if you want to use it for installing Linux on some other system. You may also format and use it for regular data storage or transfer.

If everything goes smoothly, you should see the grub screen once the system powers on. Here, you can choose Ubuntu to boot into Ubuntu and Windows boot manager to boot into Windows. Pretty cool, right?

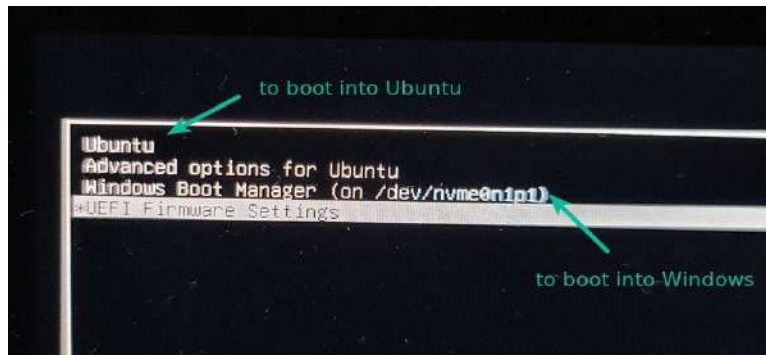

You can choose the operating system from the grub screen

Summary

Ubuntu is a type of Linux operating system that is considered free and secure. A bootable USB or disk is required for installation, followed by setup steps. After successful installation, the Linux system becomes ready for use.

Check your Progress

A. Multiple Choice Questions (MCQ)

1. Who first developed the Linux operating system? (a) Richard Stallman (b) Linus Torvalds (c) Bill Gates (d) Steve Jobs

2. What is the minimum RAM requirement for Ubuntu 22.04 LTS? (a) 512 MB (b) 1 GB (c) 2 GB (d) 4 GB
3. What is the main objective of Fedora? (a) User-friendly Interface (b) Stability and Reliability (c) Integrating the latest open-source technology (d) Dual booting
4. Which Linux installation method is considered the easiest and most user-friendly? (a) Graphical Installation (b) Network Installation (c) Text-based Installation (d) Diskless Installation
5. What is the most commonly used tool on Windows for creating a bootable USB for Ubuntu? (a) Etcher (b) VirtualBox (c) VMware (d) Rufus

B. Fill in the Blanks

1. Linux is an _____ operating system.
2. Ubuntu's long-term support (LTS) releases receive security updates for _____ years.
3. VirtualBox is a _____ software used to create virtual machines.
4. Linux Mint is primarily based on the _____ LTS release.
5. Diskless Installation runs entirely in _____ or over the network.

C. True or False

1. Debian is known for its stability and reliability.
2. Arch Linux is a heavy-weight and complex system.
3. A bootable USB can be created from an ISO file in Ubuntu.
4. Dual booting means running two different Linux distributions.
5. Etcher is a tool used to create a bootable USB on macOS.

D. Short Questions (2–3 lines answers)

1. Why is Linux called an "Open Source Operating System"?
2. What is the difference between graphical and text-based installation?
3. What is the use of VirtualBox?
4. What are the advantages of a dual boot installation?
5. Which three tools can be used to create a bootable USB for Ubuntu?

Session 2: Perform post installation task in Linux operating system

Installing a Linux operating system is just the first step, but there are several important tasks to perform afterward, called Post Installation Tasks. For example, a student like Ankit installed Ubuntu Linux on his laptop. After installation, he faced trouble connecting to the internet. He configured the network settings and updated the system. Now his computer was ready with the latest packages and security updates.

Similarly, Priyanka installed Python and other necessary software so she could start programming. Sometimes, Rahul needs to update his printer or Wi-Fi drivers to make sure the hardware works properly. In addition, creating new user accounts, setting file permissions, and configuring security settings are also important tasks.

Performing these small tasks ensures that the Linux system is fully ready and functional. Every student should complete these post-installation tasks so that their computer remains secure, fast, and prepared for all projects and daily tasks.

Activity 1

Practical Activity 2.1: Demonstrate Post installation tasks of Ubuntu Linux

Step 1. When the system boots up after a successful installation, you will see the login screen below. Log in using the username and password you created during the installation.



Step 2. After entering your credentials and pressing Enter, you will be taken to the desktop screen. You will then see the following welcome screen. Complete the setup by configuring some additional settings.

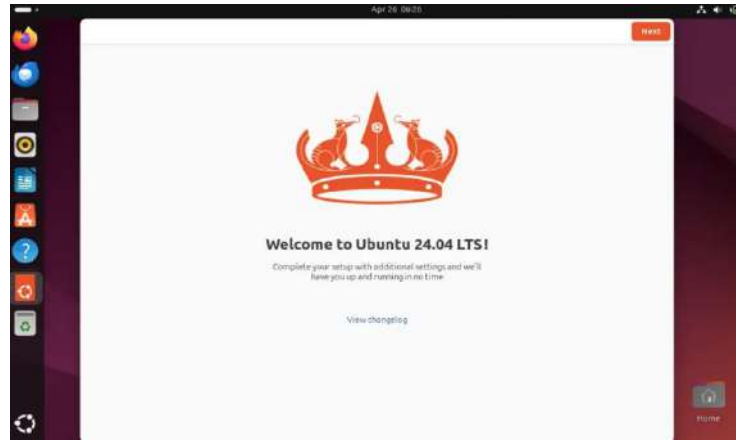

Step 3. Click on Next. In the following window, disable Ubuntu Pro by selecting "Skip for Now," then click Next.

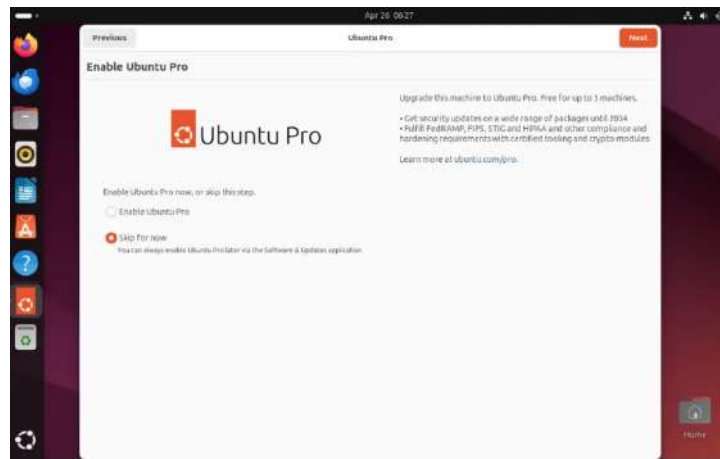

Step 4. Choose "No, don't share system data".

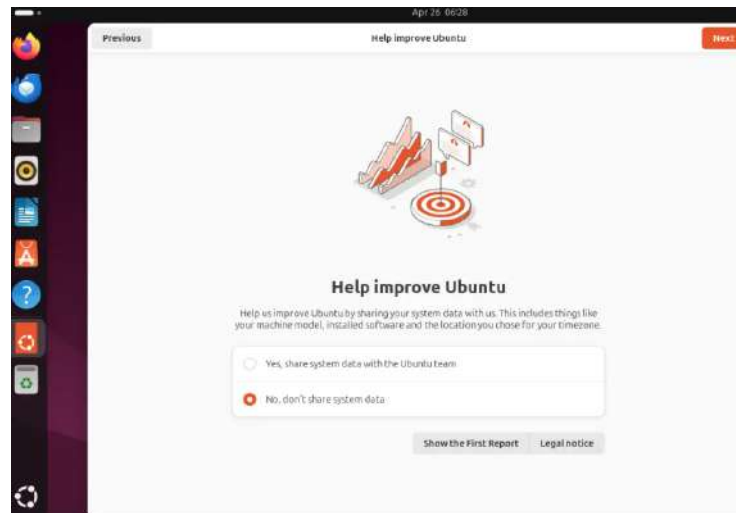

Step 5. Click on Finish to start using your Ubuntu 24.04.

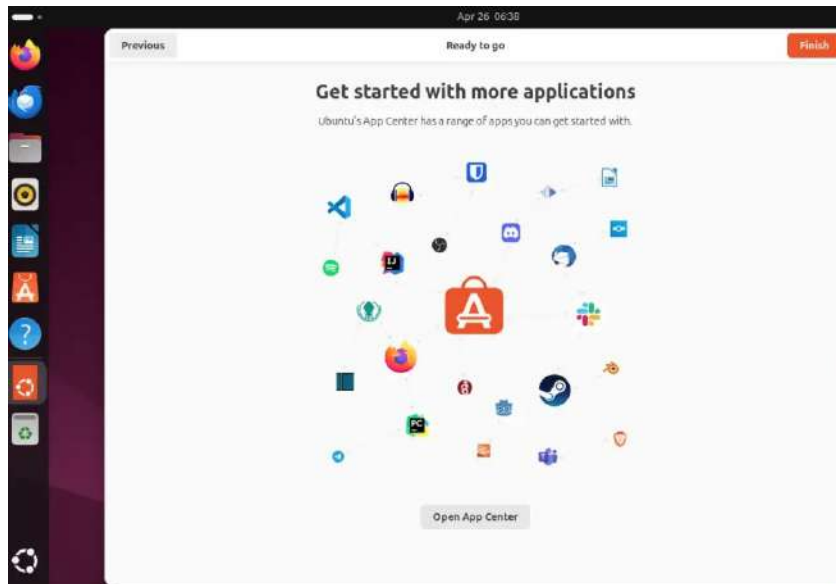

Step 6. Next, Open the terminal and install neofetch utility.

```
$ sudo apt update
```

```
$ sudo apt install neofetch -y
```

```
$ neofetch
```

```
koha@library: ~
koha@library:~$ neofetch
.-/+00SSSS00+/-
`:+SSSSSSSSSSSSSSSSSS+:`
+SSSSSSSSSSSSSSSSSYVSSSS+
.0SSSSSSSSSSSSSSSSdMMMMySSSS0.
/SSSSSSSSSShdmmNNmyNMMMMhSSSSS/
+SSSSSSSShmydMMMMMMNdddSSSSSS+
/SSSSSSShNMMMyhhyyyhNMMMMhSSSSSS/
.0SSSSSSdMMNHSSSSSSSShNMMNdSSSSSS.
+SSShhhyNMMNySSSSSSSSSyNMMMySSSSSS+
0SyNMMMNyMMhSSSSSSSSShmmhSSSSSS0
+SSShhhyNMMNySSSSSSSSSyNMMMySSSSSS+
.SSSSSSSdMMNHSSSSSSSShNMMNdSSSSSS.
/SSSSSSShNMMMyhhyyyhdNMMMMhSSSSSS/
+SSSSSSSSdmydMMMMMMNdddSSSSSS+
/SSSSSSSSSShdmmNNmyNMMMMhSSSSSS/
.0SSSSSSSSSSSSSSSSdMMMNySSSS0.
-+SSSSSSSSSSSSSSyySS+
`:+SSSSSSSSSSSSSSSS+:`
.-/+00SSSS00+/-

koha@library
-----
OS: Ubuntu 22.04.4 LTS x86_64
Host: VirtualBox 1.2
Kernel: 5.15.0-105-generic
Uptime: 18 mins
Packages: 1774 (dpkg), 9 (snap)
Shell: bash 5.1.16
Resolution: 800x600
DE: GNOME 42.9
WM: Mutter
WM Theme: Adwaita
Theme: Yaru [GTK2/3]
Icons: Yaru [GTK2/3]
Terminal: gnome-terminal
CPU: 11th Gen Intel i7-11700 (2) @
GPU: 00:02.0 VMware SVGA II Adapter
Memory: 743MiB / 4842MiB

koha@library:~$
```

Step 7. Great, output above shows that we have successfully installed Ubuntu 24.04 LTS on our system.

Procedure to install Desktop and icon themes

Installing desktop and icon themes in Ubuntu 24.04 is a straightforward process. Here's a step-by-step guide:

Activity 2

Practical activity 2.2: install Desktop and icon themes.

Step 1. For basic user usage, type “**Ubuntu Software**” in the search bar, press **Enter** to open it, and browse through the search results to find the software you’re looking for.



Step 2. Enable ‘Minimize on Click.’

If you prefer to minimize windows by clicking on the app icon, you can enable this feature using a simple command in the terminal:

```
# gsettings set org.gnome.shell.extensions.dash-to-dock click-action 'minimize'.
```

Step 3. Install GNOME Tweaks

GNOME Tweaks is a powerful tool that allows for extensive customization options such as changing themes, fonts, window behavior, and more.

You can install GNOME Tweaks through the Ubuntu Software app and access it from the applications grid by searching for “tweaks”.

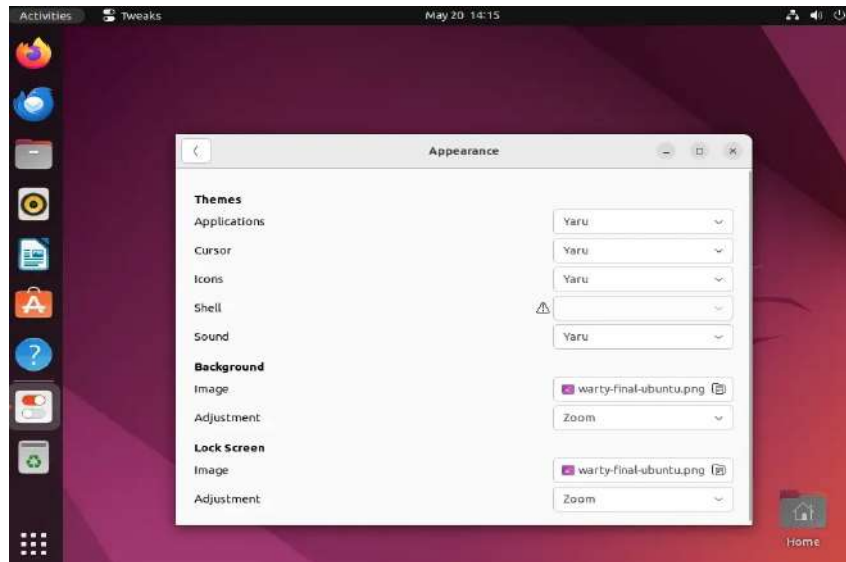

Step 4. Enable Night Light

You might want to turn on the “night light” setting in GNOME, which helps to lower the amount of blue light that comes from your screen. This can be good for your sleep. You can find this setting in the “Screen Display” part of your Settings.

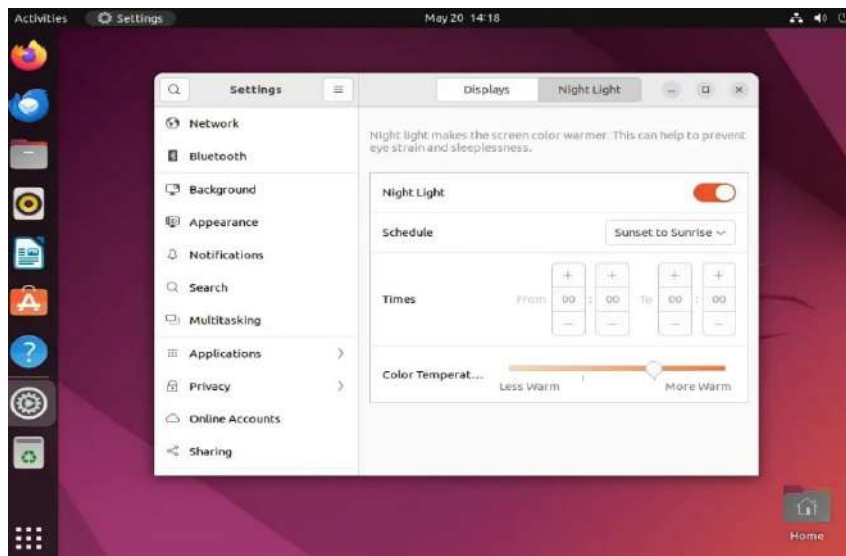

Step 5. Customize Desktop Environment

Ubuntu offers different desktop environments like GNOME, KDE, and Xfce. You can install and switch between these environments based on your preferences using terminal commands as shown.

```
#sudo apt install kubuntu-desktop.
```

Step 6. Install Snap Packages

You might want to try installing Snap packages, a new way of packaging software for Linux. It lets you get lots of different software applications and tools easily.

```
# sudo apt install snapd.
```

Basic commands in Linux:

In Ubuntu 24.04, you can perform various tasks using the command line interface (CLI). Here are some basic commands to get you started:

1. The `ls` command is fundamental in Linux, used to list the contents of a folder. It's one of the initial commands beginners learn. By simply typing `ls`, you can view the files and directories within your current location.

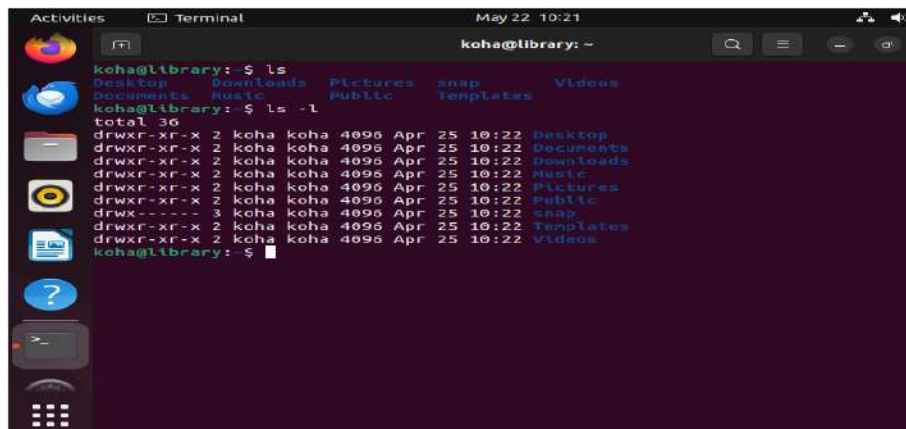

```
Activities Terminal May 22 10:21 koha@library: ~
koha@library:~$ ls
Desktop  Downloads  Pictures  snap  Videos
Documents Basic      Public   Templates
koha@library:~$ ls -l
total 36
drwxr-xr-x 2 koha koha 4096 Apr 25 10:22 Desktop
drwxr-xr-x 2 koha koha 4096 Apr 25 10:22 Documents
drwxr-xr-x 2 koha koha 4096 Apr 25 10:22 Downloads
drwxr-xr-x 2 koha koha 4096 Apr 25 10:22 Music
drwxr-xr-x 2 koha koha 4096 Apr 25 10:22 Pictures
drwx----- 3 koha koha 4096 Apr 25 10:22 snap
drwxr-xr-x 2 koha koha 4096 Apr 25 10:22 Templates
drwxr-xr-x 2 koha koha 4096 Apr 25 10:22 Videos
koha@library:~$
```

2. The `cd` command is used to change the current directory in Linux. Initially, you start in your home directory, but you may need to navigate to different directories for various tasks. For instance, suppose you've downloaded a `.deb` file or a script. While you could execute it from your current directory using the full path, changing to that directory simplifies the process. By typing `cd`, followed by the desired directory path, you can seamlessly move to another location, making it convenient to perform actions within that directory.

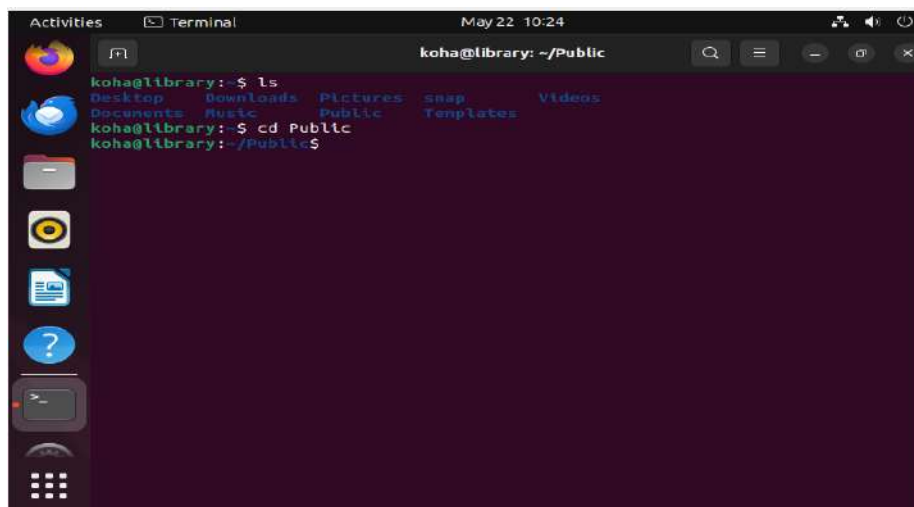

```
Activities Terminal May 22 10:24 koha@library: ~/Public
koha@library:~$ ls
Desktop  Downloads  Pictures  snap  Videos
Documents Basic      Public   Templates
koha@library:~$ cd Public
koha@library:~/Public$
```

3. The cat command is employed to quickly view the contents of a text file in Linux. When executed, it displays the contents of the file directly on the screen. To utilize the cat command, simply type cat followed by the name of the file you wish to view:

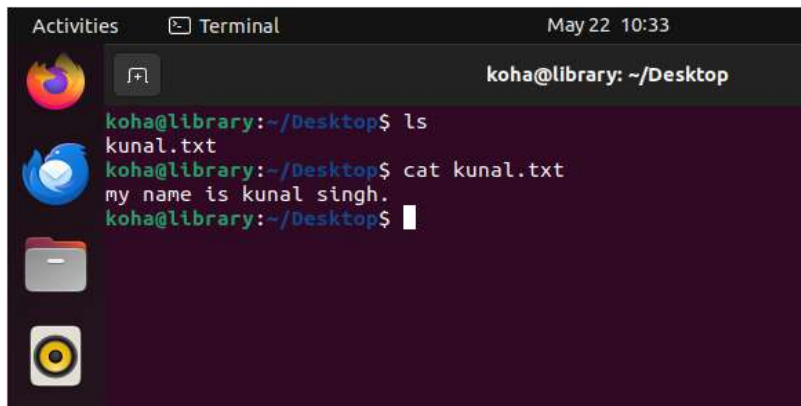

```
Activities Terminal May 22 10:33
koha@library: ~/Desktop
koha@library:~/Desktop$ ls
kunal.txt
koha@library:~/Desktop$ cat kunal.txt
my name is kunal singh.
koha@library:~/Desktop$
```

4. Less command: When dealing with large text files containing hundreds of lines, using the cat command can inundate your screen with all the text, making it unwieldy to navigate. Instead, the less command provides a more manageable solution. By opening a file with less, it presents the file in pages, allowing you to navigate through the content more efficiently. You can scroll up and down, search for specific text, and perform various other actions. Using less is recommended for working with large text files to avoid overwhelming your screen.

Example usage:

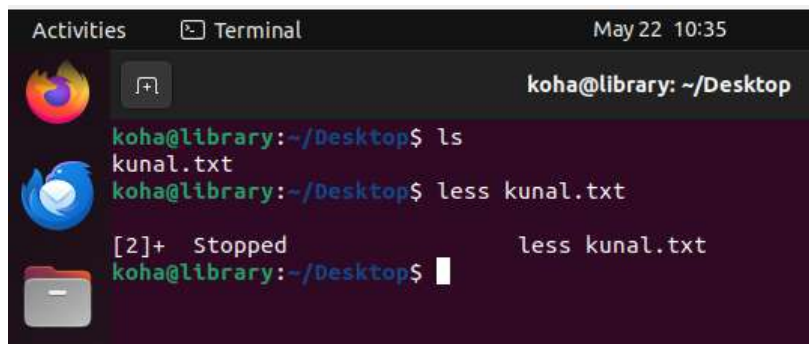

```
Activities Terminal May 22 10:35
koha@library: ~/Desktop
koha@library:~/Desktop$ ls
kunal.txt
koha@library:~/Desktop$ less kunal.txt
[2]+ Stopped less kunal.txt
koha@library:~/Desktop$
```

5. The touch command offers a simple method for creating new files in the Linux terminal. While other commands like cat can also accomplish this task, touch is specifically designed for creating new empty files. To use touch, simply specify the name of the new file you wish to create:

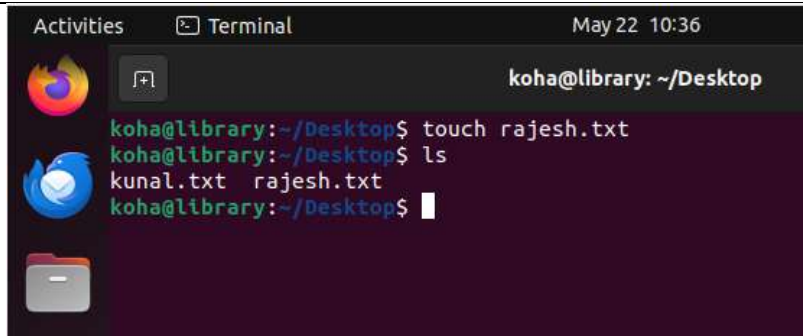

```

Activities Terminal May 22 10:36
koha@library: ~/Desktop
koha@library:~/Desktop$ touch rajesh.txt
koha@library:~/Desktop$ ls
kunal.txt rajesh.txt
koha@library:~/Desktop$

```

6. `mkdir` is a command in Linux used to create directories or folders. It stands for "make directory". To use `mkdir`, simply type the command followed by the name of the directory you want to create.

Example:

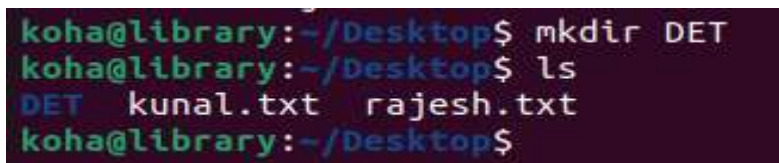

```

koha@library:~/Desktop$ mkdir DET
koha@library:~/Desktop$ ls
DET kunal.txt rajesh.txt
koha@library:~/Desktop$

```

7. The `cp` command, abbreviated for "copy", is a frequently used command line tool for duplicating files and directories. To utilize `cp`, simply specify the source file or directory followed by the destination where you want to copy it.

Example:

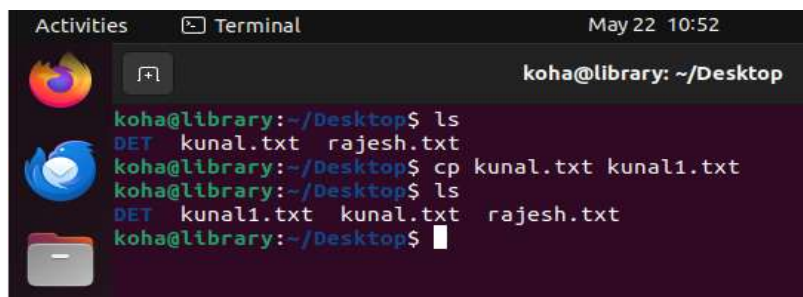

```

Activities Terminal May 22 10:52
koha@library: ~/Desktop
koha@library:~/Desktop$ ls
DET kunal.txt rajesh.txt
koha@library:~/Desktop$ cp kunal.txt kunal1.txt
koha@library:~/Desktop$ ls
DET kunal1.txt kunal.txt rajesh.txt
koha@library:~/Desktop$

```

8. **rm command: Remove files and folders**

You use the `rm` (short for remove) command to delete files in the Linux terminal.

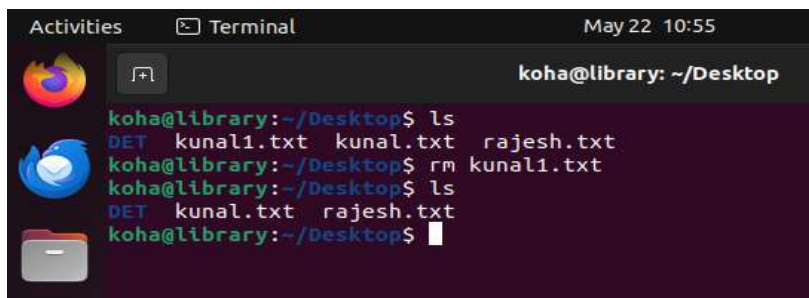

```

Activities Terminal May 22 10:55
koha@library: ~/Desktop
koha@library:~/Desktop$ ls
DET kunal1.txt kunal.txt rajesh.txt
koha@library:~/Desktop$ rm kunal1.txt
koha@library:~/Desktop$ ls
DET kunal.txt rajesh.txt
koha@library:~/Desktop$

```

9. The `nano` command is used to edit files in the Linux terminal. Nano is a simple, user-

friendly text editor that allows you to create and modify files directly from the command line. To open a file in nano, type:

nano filename

This command opens the specified file in the nano text editor, where you can make your edits. To save your changes and exit, use the following key combinations:

Save: Ctrl + O (then press Enter)

Exit: Ctrl + X

The screenshot shows a terminal window titled 'koha@library: ~/Desktop'. Inside, the GNU nano 6.2 text editor is open, editing a file named 'kunal.txt'. The text 'my name is kunal singh.' is visible on the first line. The bottom status bar shows various keyboard shortcuts: ^G Help, ^O Write Out, ^W Where Is, ^K Cut, ^X Exit, ^R Read File, ^\ Replace, and ^U Paste.

10. The ps command is for handling the processes running on your system. Each process has an associated ID called PID, which can be used for various purposes, such as [terminating a process](#).

The screenshot shows a terminal window titled 'Activities Terminal' with the date and time 'May 22 11:53'. The user 'koha@library' is at the prompt '~'. The command 'ps' has been executed, resulting in the following output:

```

koha@library:~$ ps
  PID TTY          TIME CMD
 17193 pts/0    00:00:00 bash
 17204 pts/0    00:00:00 ps
koha@library:~$

```

Here,

- PID: Process ID
- TTY: Controlling terminal associated with the process (Not that important these days)
- TIME: Total CPU usage time
- CMD: Name of command that runs the process

Commands for update, upgrade, install and remove packages

In Ubuntu 24.04, package management is primarily handled using the apt command. Here

are the commands for updating, upgrading, installing, and removing packages:

1. Update Package List

Updating the package list ensures you have the latest information about available packages and their versions.

```
#sudo apt update
```

2. Upgrade Installed Packages

Upgrading packages installs the latest versions of all currently installed packages.

```
# sudo apt upgrade
```

3. Install a Package

To install a specific package, use the install command followed by the package name.

```
# sudo apt install package_name
```

4. Remove a Package

To remove a specific package, use the remove command followed by the package name.

```
# sudo apt remove package_name
```

5. Remove Unused Packages

After removing packages, you might have some unused dependencies left over. Clean them up using:

```
# sudo apt autoremove
```

Activity 3

Practical Activity 2.3: Demonstrate to update, upgrade, install and remove packages using commands

Step 1. Update Packages with apt update

The apt update command refreshes the local package repository with the latest metadata, ensuring you have the most current information about available packages and their versions. Running this command before any upgrades or installations is essential to ensure you get the latest versions of packages.

```
# sudo apt update
```

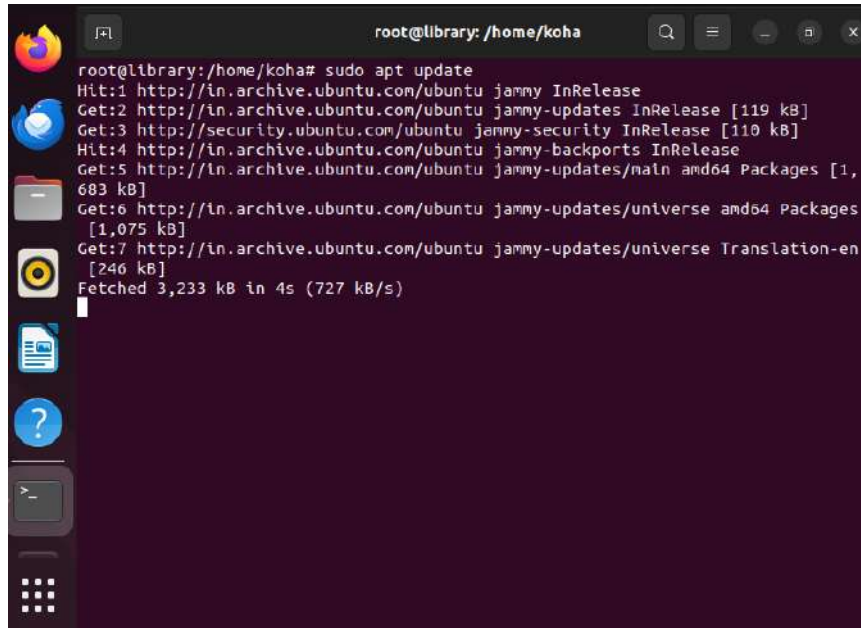

```

root@library: /home/koha# sudo apt update
Hit:1 http://in.archive.ubuntu.com/ubuntu jammy InRelease
Get:2 http://in.archive.ubuntu.com/ubuntu jammy-updates InRelease [119 kB]
Get:3 http://security.ubuntu.com/ubuntu jammy-security InRelease [110 kB]
Hit:4 http://in.archive.ubuntu.com/ubuntu jammy-backports InRelease
Get:5 http://in.archive.ubuntu.com/ubuntu jammy-updates/main amd64 Packages [1,683 kB]
Get:6 http://in.archive.ubuntu.com/ubuntu jammy-updates/universe amd64 Packages [1,075 kB]
Get:7 http://in.archive.ubuntu.com/ubuntu jammy-updates/universe Translation-en [246 kB]
Fetched 3,233 kB in 4s (727 kB/s)

```

This command will also display a list of packages that can be upgraded.

Step 2. Upgrade Packages with apt upgrade

Use the apt upgrade command to update all installed packages to their latest versions. Running this command without specifying a package name will upgrade all packages on the system:

```
# sudo apt upgrade.
```

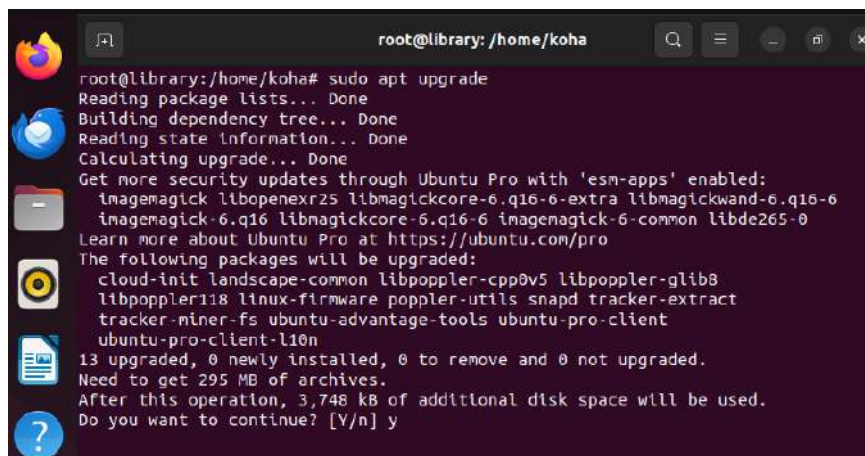

```

root@library: /home/koha# sudo apt upgrade
Reading package lists... Done
Building dependency tree... Done
Reading state information... Done
Calculating upgrade... Done
Get more security updates through Ubuntu Pro with 'esm-apps' enabled:
  imagemagick libopenexr25 libmagickcore-6.q16-6-extra libmagickwand-6.q16-6
  imagemagick-6.q16 libmagickcore-6.q16-6 imagemagick-6-common libde265-0
Learn more about Ubuntu Pro at https://ubuntu.com/pro
The following packages will be upgraded:
  cloud-init landscape-common libpoppler-cpp0v5 libpoppler-glib8
  libpoppler18 linux-firmware poppler-utils snapd tracker-extract
  tracker-miner-fs ubuntu-advantage-tools ubuntu-pro-client
  ubuntu-pro-client-l10n
13 upgraded, 0 newly installed, 0 to remove and 0 not upgraded.
Need to get 295 MB of archives.
After this operation, 3,748 kB of additional disk space will be used.
Do you want to continue? [Y/n] y

```

To upgrade a specific package, append the name:

```
# sudo apt upgrade lsof.
```

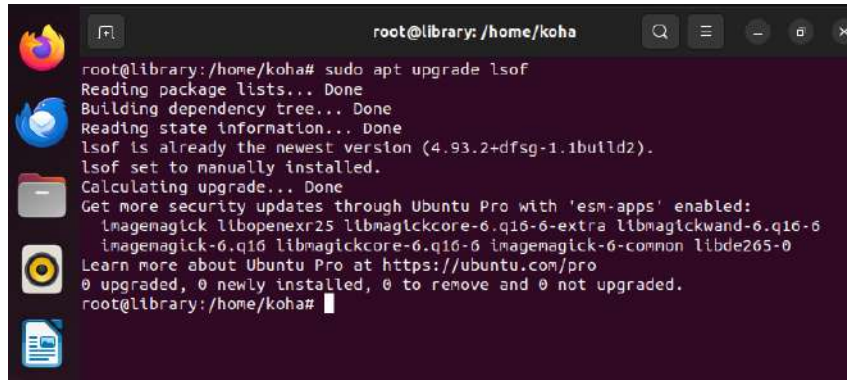

```

root@library: /home/koha# sudo apt upgrade lsof
Reading package lists... Done
Building dependency tree... Done
Reading state information... Done
lsof is already the newest version (4.93.2+dfsg-1.1build2).
lsof set to manually installed.
Calculating upgrade... Done
Get more security updates through Ubuntu Pro with 'esm-apps' enabled:
  imagemagick libopenexr25 libmagickcore-6.q16-6-extra libmagickwand-6.q16-6
  imagemagick-6.q16 libmagickcore-6.q16-6 imagemagick-6-common libde265-0
Learn more about Ubuntu Pro at https://ubuntu.com/pro
0 upgraded, 0 newly installed, 0 to remove and 0 not upgraded.
root@library: /home/koha#

```

The update and upgrade commands also print output when executed together. To run these commands in one step and avoid being asked to confirm the process, use the -y flag:

```
sudo apt update && sudo apt upgrade -y
```

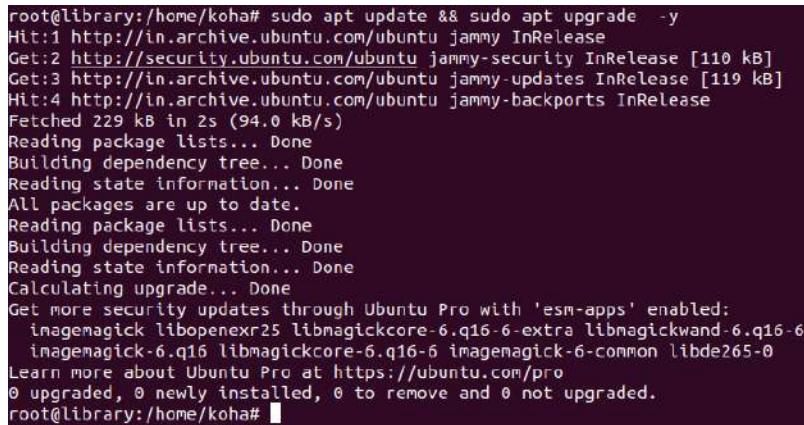

```

root@library: /home/koha# sudo apt update && sudo apt upgrade -y
Hit:1 http://in.archive.ubuntu.com/ubuntu jammy InRelease
Get:2 http://security.ubuntu.com/ubuntu jammy-security InRelease [110 kB]
Get:3 http://in.archive.ubuntu.com/ubuntu jammy-updates InRelease [119 kB]
Hit:4 http://in.archive.ubuntu.com/ubuntu jammy-backports InRelease
Fetched 229 kB in 2s (94.0 kB/s)
Reading package lists... Done
Building dependency tree... Done
Reading state information... Done
All packages are up to date.
Reading package lists... Done
Building dependency tree... Done
Reading state information... Done
Calculating upgrade... Done
Get more security updates through Ubuntu Pro with 'esm-apps' enabled:
  imagemagick libopenexr25 libmagickcore-6.q16-6-extra libmagickwand-6.q16-6
  imagemagick-6.q16 libmagickcore-6.q16-6 imagemagick-6-common libde265-0
Learn more about Ubuntu Pro at https://ubuntu.com/pro
0 upgraded, 0 newly installed, 0 to remove and 0 not upgraded.
root@library: /home/koha#

```

Step 3. Full-Upgrade Packages with apt full-upgrade

The apt full-upgrade command updates all installed packages and removes any packages as necessary to complete the upgrade. This command is particularly useful at the end of a distribution release's life cycle to ensure the entire system is fully upgraded.

```
# sudo apt full-upgrade
```

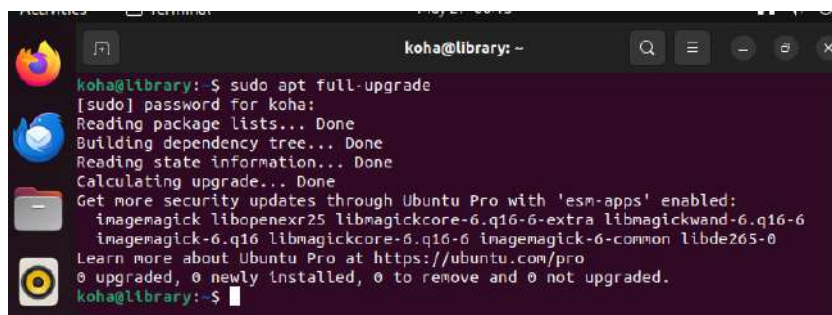

```

koha@library: ~$ sudo apt full-upgrade
[sudo] password for koha:
Reading package lists... Done
Building dependency tree... Done
Reading state information... Done
Calculating upgrade... Done
Get more security updates through Ubuntu Pro with 'esm-apps' enabled:
  imagemagick libopenexr25 libmagickcore-6.q16-6-extra libmagickwand-6.q16-6
  imagemagick-6.q16 libmagickcore-6.q16-6 imagemagick-6-common libde265-0
Learn more about Ubuntu Pro at https://ubuntu.com/pro
0 upgraded, 0 newly installed, 0 to remove and 0 not upgraded.
koha@library: ~$

```

Step 4. Install Packages with apt install

Use the apt install command to install a specific package from the repository.

```
# sudo apt install ffmpeg
```

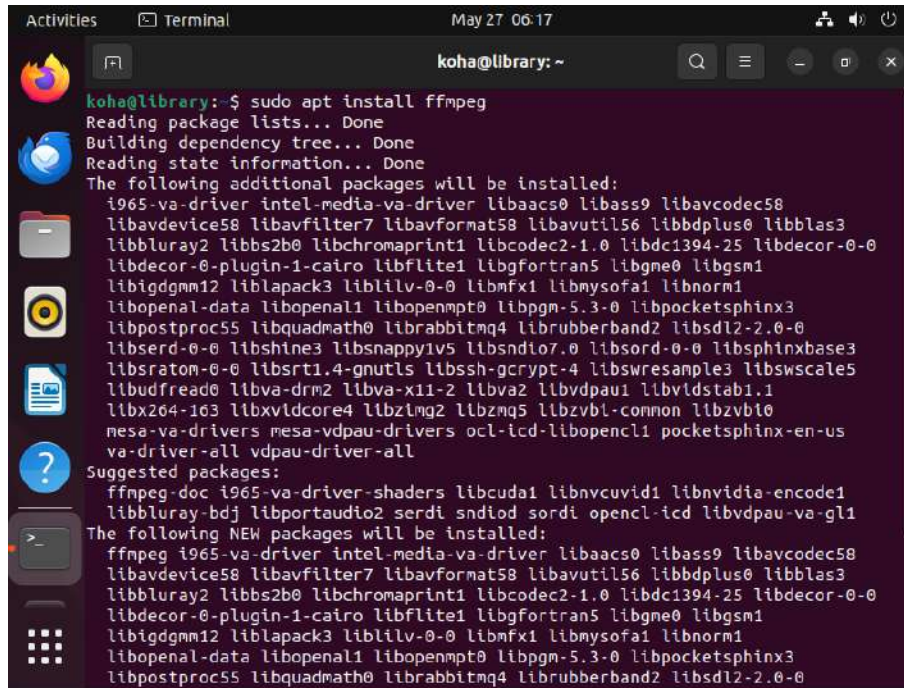

```

koha@library: ~
koha@library:~$ sudo apt install ffmpeg
Reading package lists... Done
Building dependency tree... Done
Reading state information... Done
The following additional packages will be installed:
  i965-va-driver intel-media-va-driver libaac0 libass9 libavcodec58
  libavdevice58 libavfilter7 libavformat58 libavutil56 libbdplus0 libblas3
  libbluray2 libbs2b0 libchromaprint1 libcodec2-1.0 libdc1394-25 libdecor-0-0
  libdecor-0-plugin-1-cairo libflite1 libgfortran5 libgme0 libgsm1
  libigdgmm12 liblapack3 liblilv-0-0 libmfx1 libmysofa1 libnorm1
  libopenal-data libopenal1 libopenmpt0 libpgm-5.3-0 libpocketsphinx3
  libpostproc55 libquadmath0 librabbitmq4 librubberband2 libsd12-2.0-0
  libserd-0-0 libshine3 libsnappy1v5 libsndio7.0 libsoxr-0-0 libsoxsf1
  libsratom-0-0 libsrtp1.4-gnutls libssh-gcrypt-4 libswresample3 libswscats
  libudfread0 libva-drm2 libva-x11-2 libva2 libvdpau1 libvldstab1.1
  libx264-163 libxvidcore4 libzimg2 libzmq5 libzvt-common libzvt0
  mesa-va-drivers mesa-va-drivers ocl-icd-libopencl1 pocketsphinx-en-us
  va-driver-all vdpau-driver-all
Suggested packages:
  ffmpeg-doc i965-va-driver-shaders libcuda1 libnvcuvid1 libnvidia-encode1
  libbluray-bdj libportaudio2 serdi sndiod sordi opencl-icd libvdpau-va-gli
The following NEW packages will be installed:
  ffmpeg i965-va-driver intel-media-va-driver libaac0 libass9 libavcodec58
  libavdevice58 libavfilter7 libavformat58 libavutil56 libbdplus0 libblas3
  libbluray2 libbs2b0 libchromaprint1 libcodec2-1.0 libdc1394-25 libdecor-0-0
  libdecor-0-plugin-1-cairo libflite1 libgfortran5 libgme0 libgsm1
  libigdgmm12 liblapack3 liblilv-0-0 libmfx1 libmysofa1 libnorm1
  libopenal-data libopenal1 libopenmpt0 libpgm-5.3-0 libpocketsphinx3
  libpostproc55 libquadmath0 librabbitmq4 librubberband2 libsd12-2.0-0

```

Step 5. Only Download Packages with apt download

The apt download-only feature allows users to use deb files without installing them. To download packages without starting the installation, run:

```
# sudo apt download apache2
```

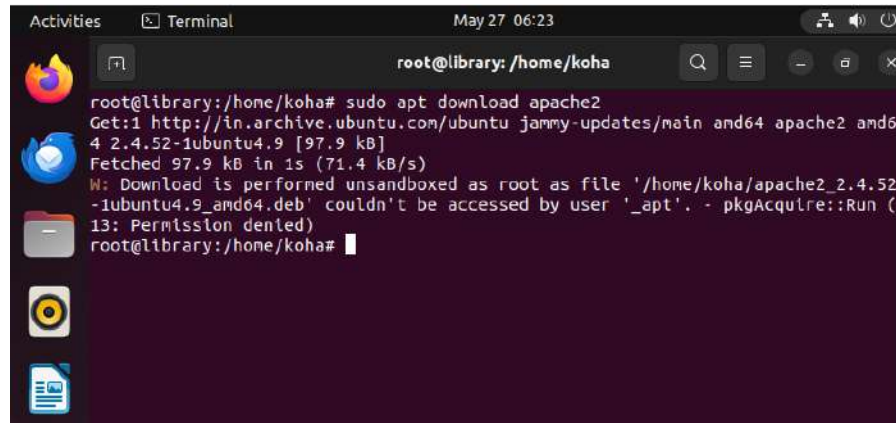

```

root@library: /home/koha
root@library:/home/koha# sudo apt download apache2
Get:1 http://in.archive.ubuntu.com/ubuntu jammy-updates/main amd64 apache2 amd64
  2.4.52-1ubuntu4.9 [97.9 kB]
Fetched 97.9 kB in 1s (71.4 kB/s)
W: Download is performed unsandboxed as root as file '/home/koha/apache2_2.4.52-
  1ubuntu4.9_amd64.deb' couldn't be accessed by user '_apt'. - pkgAcquire::Run (
  13: Permission denied)
root@library:/home/koha#

```

Step 6. Remove Packages with apt remove

To uninstall a specific package, use the apt remove command.

```
# sudo apt remove ffmpeg
```

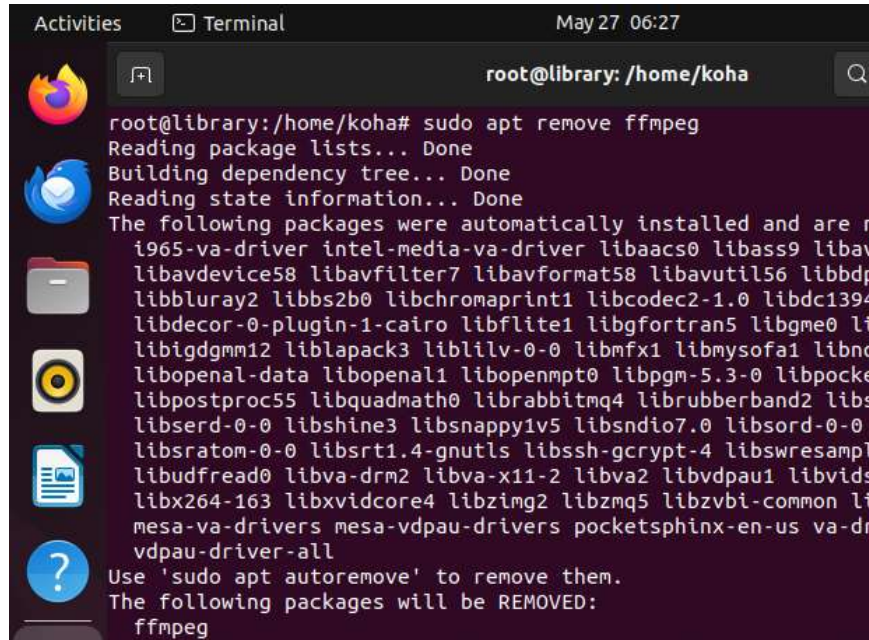

```

root@library: /home/koha
root@library:/home/koha# sudo apt remove ffmpeg
Reading package lists... Done
Building dependency tree... Done
Reading state information... Done
The following packages were automatically installed and are now
i965-va-driver intel-media-va-driver libaacs0 libass9 libav
libavdevice58 libavfilter7 libavformat58 libavutil56 libbdp
libbluray2 libbs2b0 libchromaprint1 libcodec2-1.0 libdc1394
libdecor-0-plugin-1-cairo libflite1 libgfortran5 libgme0 li
libigdmm12 liblapack3 liblilv-0-0 libmfx1 libmysofa1 libno
libopenal-data libopenal1 libopenmpt0 libpgm-5.3-0 libpocke
libpostproc55 libquadmath0 librabbitmq4 librubberband2 libse
libserd-0-0 libshine3 libsnappy1v5 libsndio7.0 libsord-0-0
libsratom-0-0 libsrtp1.4-gnutls libssh-gcrypt-4 libswresampl
libudfread0 libva-drm2 libva-x11-2 libva2 libvdpau1 libvids
libx264-163 libxvidcore4 libzing2 libzmq5 libzvbi-common li
mesa-va-drivers mesa-vdpau-drivers pocketsphinx-en-us va-dr
vdpau-driver-all
Use 'sudo apt autoremove' to remove them.
The following packages will be REMOVED:
ffmpeg

```

Step 7. Remove All Configuration Files with apt purge

The apt remove command deletes the specified packages but may leave behind configuration files. To delete both the package and its configuration files, use the apt purge command.

```
# sudo apt purge ffmpeg
```

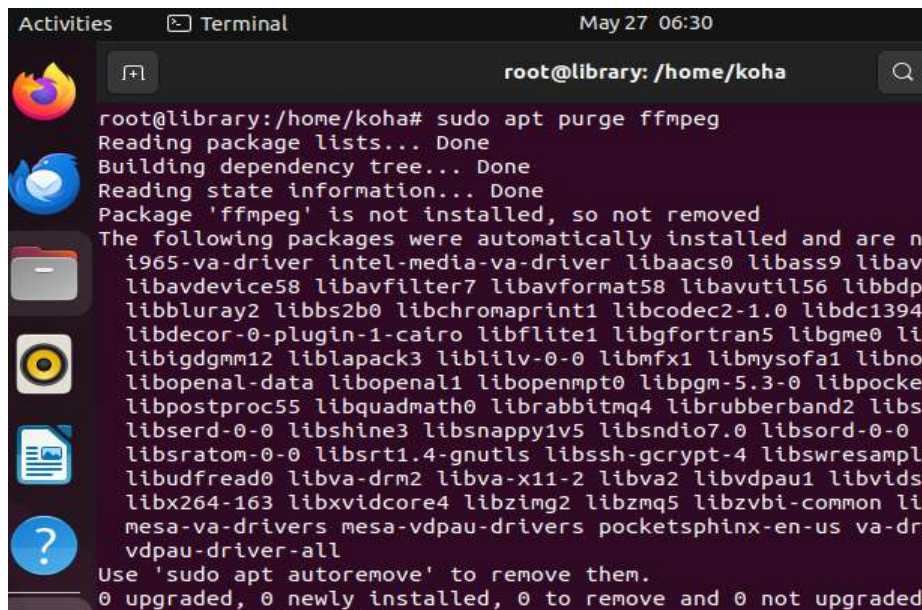

```

root@library: /home/koha
root@library:/home/koha# sudo apt purge ffmpeg
Reading package lists... Done
Building dependency tree... Done
Reading state information... Done
Package 'ffmpeg' is not installed, so not removed
The following packages were automatically installed and are now
i965-va-driver intel-media-va-driver libaacs0 libass9 libav
libavdevice58 libavfilter7 libavformat58 libavutil56 libbdp
libbluray2 libbs2b0 libchromaprint1 libcodec2-1.0 libdc1394
libdecor-0-plugin-1-cairo libflite1 libgfortran5 libgme0 li
libigdmm12 liblapack3 liblilv-0-0 libmfx1 libmysofa1 libno
libopenal-data libopenal1 libopenmpt0 libpgm-5.3-0 libpocke
libpostproc55 libquadmath0 librabbitmq4 librubberband2 libse
libserd-0-0 libshine3 libsnappy1v5 libsndio7.0 libsord-0-0
libsratom-0-0 libsrtp1.4-gnutls libssh-gcrypt-4 libswresampl
libudfread0 libva-drm2 libva-x11-2 libva2 libvdpau1 libvids
libx264-163 libxvidcore4 libzing2 libzmq5 libzvbi-common li
mesa-va-drivers mesa-vdpau-drivers pocketsphinx-en-us va-dr
vdpau-driver-all
Use 'sudo apt autoremove' to remove them.
0 upgraded, 0 newly installed, 0 to remove and 0 not upgraded

```

Step 8. Remove Unused Dependencies with apt autoremove

When packages are removed, their dependencies may remain on the system. To clean up these unneeded dependencies and free up space, use the apt autoremove command.

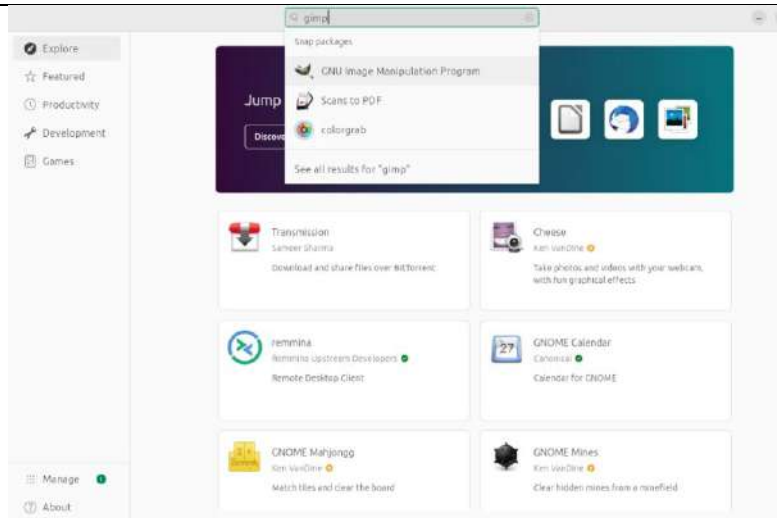

Activity 4

Practical Activity 2.4: Demonstrate to Install Package using Software Center using command line.

Step 1. First, press Ctrl+Alt+T on keyboard to open a terminal window. When it opens, run command:

```
snap refresh snap-store --channel=latest/stable/ubuntu-24.04
```

```

root@library: /home/koha
root@library:/home/koha# snap refresh snap-store --channel=latest/stable/ubuntu-24.04
snap-store (stable/ubuntu-24.04) 0+git.97116aa from Canonical ✓ refreshed
root@library:/home/koha#

```

Step 2. After that, just press Super (windows logo) key to open overview screen, search and launch “App Center”.

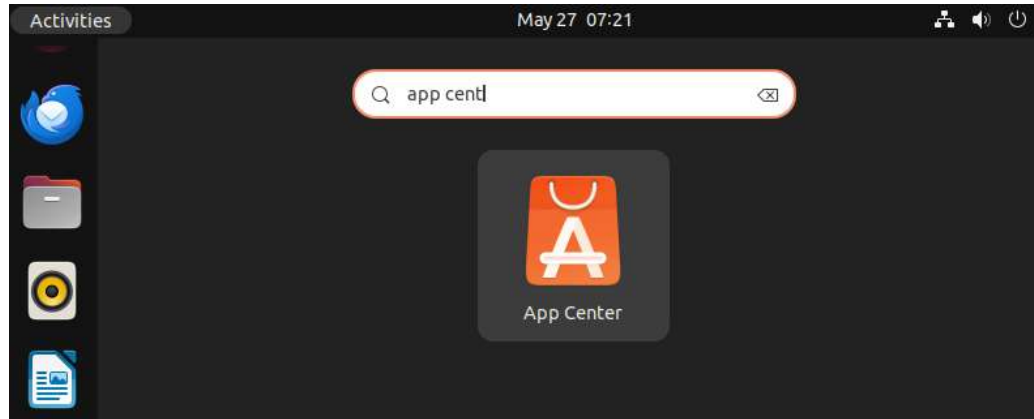

Demonstrate to download and install Debian Packages

Practical Activity: Downloading and installing Debian packages in Ubuntu 24.04 can be done using the following steps:

1. Download the Debian Package:

You can download the Debian package (with the .deb extension) from the internet or obtain it from other sources.

2. Open Terminal:

Open the terminal by searching for "Terminal" in the applications menu or by pressing Ctrl + Alt + T.

3. Navigate to the Download Directory:

Use the cd command to navigate to the directory where the Debian package is downloaded. For example:

```
# cd ~/Downloads
```

4. Install the Debian Package:

Install the downloaded Debian package using the dpkg command. Replace package_name.deb with the actual name of the Debian package.

```
# sudo dpkg -i package_name.deb
```

5. Resolve Dependencies (if any):

If the installation fails due to unmet dependencies, run the following command to install the required dependencies:

```
# sudo apt install -f
```

6. Verify Installation:

Once the installation is complete, you can verify if the package is installed correctly.

7. Clean Up (optional):

You can remove the downloaded Debian package from the download directory to free up space, if desired.

Connecting to the Internet

Setting up a network in Ubuntu can vary in complexity depending on your needs. Canonical has designed Ubuntu to be user-friendly, even for those without extensive technical knowledge. Despite its simplicity, Ubuntu has robust networking capabilities that enable connections to local devices or servers worldwide.

Typically, Ubuntu's networking settings work seamlessly, but there may be occasions when you need to troubleshoot or configure settings manually. Whether you're facing issues or just curious about network configurations, it's helpful to start by checking your Ubuntu system's local IP address, public IP address, default gateway, and DNS information.

Software Requirements and Linux Command Line Conventions

Category	Requirements, Conventions, or Software Version Used
System	Ubuntu 18.04, 20.04, 22.04, 24.04
Software	Netplan (installed by default)
Other	Privileged access to your Linux system as root or via the sudo command.
Conventions	# – Commands that need to be executed with root privileges, either directly as the root user or using sudo. \$ – Commands that can be executed as a regular non-privileged user.

<https://linuxconfig.org/ubuntu-22-04-network-configuration>

Ubuntu Network Setup – Local and Public IP Addresses

When your system is connected to the internet, it typically uses two IP addresses:

1. Local IP Address:

- This is the address your system uses to communicate with other devices on your local network, such as your router and other connected devices.

2. Public IP Address:

- This address is visible to devices on the internet. It is routable on the World Wide Web, allowing you to connect to servers and other devices globally. Usually, a home network has a single public IP address shared by all devices connected to the router.

Different networking setups exist, but this is the most common scenario for home networks.

Step 1. To see your local IP address, you can run the following command in terminal:

```
# ip a
```

```

root@library:/home/koha# ip a
1: lo: <LOOPBACK,UP,LOWER_UP> mtu 65536 qdisc noqueue state UNKNOWN group defau
lt qlen 1000
    link/loopback 00:00:00:00:00:00 brd 00:00:00:00:00:00
    inet 127.0.0.1/8 scope host lo
        valid_lft forever preferred_lft forever
    inet6 ::1/128 scope host
        valid_lft forever preferred_lft forever
2: enp0s3: <BROADCAST,MULTICAST,UP,LOWER_UP> mtu 1500 qdisc fq_codel state UP g
roup default qlen 1000
    link/ether 08:00:27:43:f6:7a brd ff:ff:ff:ff:ff:ff
    inet 172.30.13.100/23 brd 172.30.13.255 scope global dynamic noprefixroute
    enp0s3
        valid_lft 59731sec preferred_lft 59731sec
    inet6 fe80::a00:27ff:fe43:f67a/64 scope link
        valid_lft forever preferred_lft forever
root@library:/home/koha#

```

Step 2. There are several methods to find your public IP address. You can visit a website like IP Chicken or use one of the following commands in the terminal:

```
#echo $(wget -qO - https://api.ipify.org)
```

OR

```
echo $(curl -s https://api.ipify.org)
```

Step 3. To check the currently used DNS server IP address, execute the following command:

```
#systemd-resolve --status | grep Current
```

Step4. To display the default gateway IP address, run the following command:

```
# ip r
```

```

root@library:/home/koha# ip r
default via 172.30.12.249 dev enp0s3 proto dhcp metric 100
169.254.0.0/16 dev enp0s3 scope link metric 1000
172.30.12.0/23 dev enp0s3 proto kernel scope link src 172.30.13.100 metric 100
root@library:/home/koha#

```

Step 5. You can also check this information using the Ubuntu desktop GUI. To view the internal IP address, default gateway, MAC address, and DNS server settings:

1. Open Settings.
2. Click on the Network menu.
3. Select the gear icon next to the desired network interface.

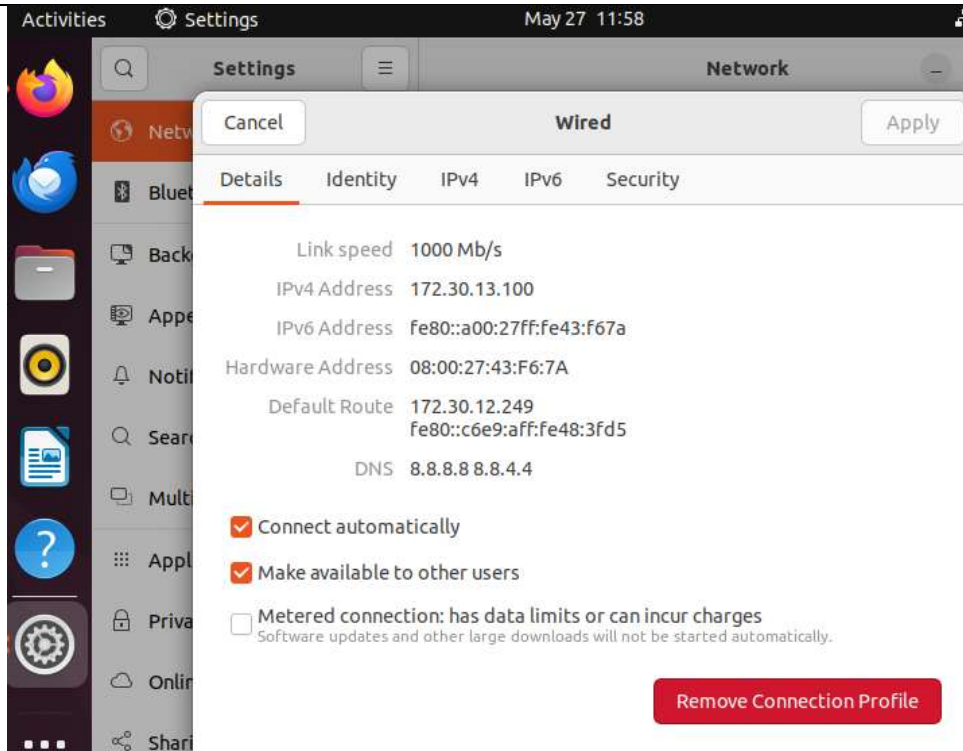

Summary

After installing Linux, software updates, additional application installations, user settings, and security configurations are performed. These steps make the system more secure and efficient.

Check Your Progress

A. Multiple choice questions

1. Which utility is installed to display system information after Ubuntu installation? (a) neofetch (b) top (c) htop (d) dmesg
2. Which command is used to update the package index on Ubuntu? (a) apt upgrade (b) apt remove (c) apt update (d) apt install
3. Which screen appears after successful Ubuntu installation before login? (a) Desktop (b) Welcome (c) Bootloader (d) Terminal
4. Which command is used to install packages in Ubuntu? (a) yum install (b) sudo install (c) apt install (d) rpm install
5. The default user permissions can be managed using which utility? (a) passwd (b) useradd (c) groupadd (d) All of the above

B. Fill in the Blanks

1. After installing Ubuntu, the screen you see before login is called the _____ screen.
2. To install new software on Ubuntu, use the command _____.
3. The command used to create a new user in Ubuntu is _____.
4. To check the currently used DNS server in Ubuntu, the command _____ is used.
5. The output of installing all updates is displayed using the _____ command.

C. True or False

1. Linux is not available for download from the internet.
2. You can permanently mount file systems by modifying etc/fstab.
3. The first login after installation requires the root account by default.
4. neofetch is a utility that shows disk space usage.
5. After successful Ubuntu installation, the system should be updated and optimized.

D. Short Questions

1. List two important post-installation tasks in Ubuntu.
2. What command is used to display system information in Ubuntu?
3. How can users modify system settings after the first login?
4. What is the purpose of updating the package index?
5. How do you check your current default gateway in Ubuntu?

Session 3. Install and Configure Peripheral devices**Overview of Linux Peripheral devices**

Peripheral devices, while not essential for basic computer operation, significantly enhance its functionality by providing input, output, or both. Input devices allow users to interact with the computer, while output devices display or transmit information.

Examples of input devices include:

- Keyboard: Allows users to input text and commands.
- Mouse: Provides a graphical interface for navigating and selecting items on the screen.
- Scanner: Converts physical documents or images into digital format.
- Microphone: Captures audio input for voice commands, recording, or communication.

Examples of output devices include:

- Printer: Produces hard copies of digital documents or images.
- Speaker: Outputs audio for listening to music, videos, or other multimedia content.
- Display: Presents visual output in the form of text, images, and videos on a screen.

Peripheral devices enhance the overall user experience and functionality of a computer system by facilitating communication and interaction between users and the digital environment.

User Management in ubuntu 24.04

User management in Ubuntu 24.04 involves creating, modifying, and deleting user accounts, as well as managing user permissions and groups. Here are some basic commands and steps to manage users effectively:

1. Adding a New User

The `useradd` command in Ubuntu is a low-level utility for creating new user accounts. It provides more granular control compared to the `adduser` command, which is a higher-level command with interactive prompts. To add a new user, use the `adduser` command, which is more user-friendly than the `useradd` command.

syntax : `sudo adduser username`.

Common Options used in ubuntu 24.04

Here are some common options you can use with `useradd`:

- d, --home HOME_DIR: Specify the home directory for the new user.
- m, --create-home: Create the user's home directory if it does not exist.
- s, --shell SHELL: Specify the login shell for the new user.
- c, --comment COMMENT: Add a comment (usually the full name of the user).
- g, --gid GROUP: Specify the primary group for the new user.
- G, --groups GROUP1,GROUP2: Specify additional groups for the new user.
- u, --uid UID: Specify the user ID for the new user.
- p, --password PASSWORD: Specify the encrypted password for the new user.

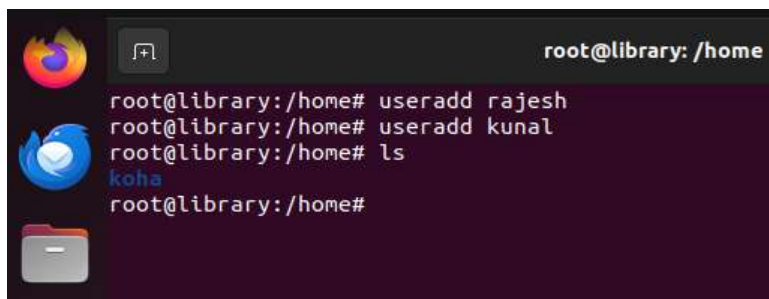

```

root@library: /home
root@library:/home# useradd rajesh
root@library:/home# useradd kunal
root@library:/home# ls
koha
root@library:/home#
  
```

Check add user in ubuntu 24.04 :

Syntax : `tail /etc/passwd`

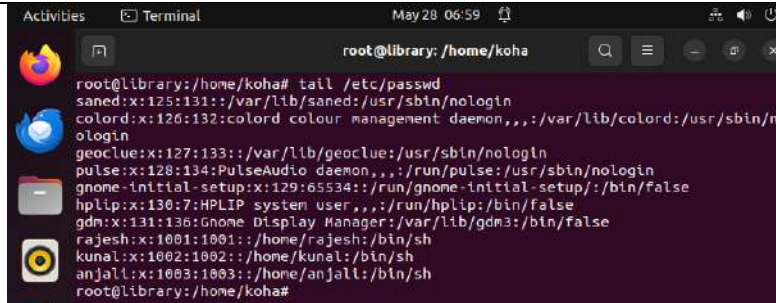

```

root@library: /home/koha# tail /etc/passwd
saned:x:125:131::/var/lib/saned:/usr/sbin/nologin
colord:x:126:132:colord colour management daemon,,,:/var/lib/colord:/usr/sbin/nologin
geoclue:x:127:133::/var/lib/geoclue:/usr/sbin/nologin
pulse:x:128:134:PulseAudio daemon,,,:/run/pulse:/usr/sbin/nologin
gnome-initial-setup:x:129:65534::/run/gnome-initial-setup:/bin/false
hplip:x:130:7:HPLIP system user,,,:/run/hplip:/bin/false
gdm:x:131:136:Gnome Display Manager:/var/lib/gdm3:/bin/false
rajesh:x:1001:1001::/home/rajesh:/bin/sh
kunal:x:1002:1002::/home/kunal:/bin/sh
anjall:x:1003:1003::/home/anjall:/bin/sh
root@library: /home/koha#

```

2. Deleting a User

The userdel command in Ubuntu is used to delete a user account and optionally remove the user's home directory and mail spool. This command requires root privileges, so you will need to use sudo to execute it. To remove a user, use the deluser command:

syntax : sudo deluser username

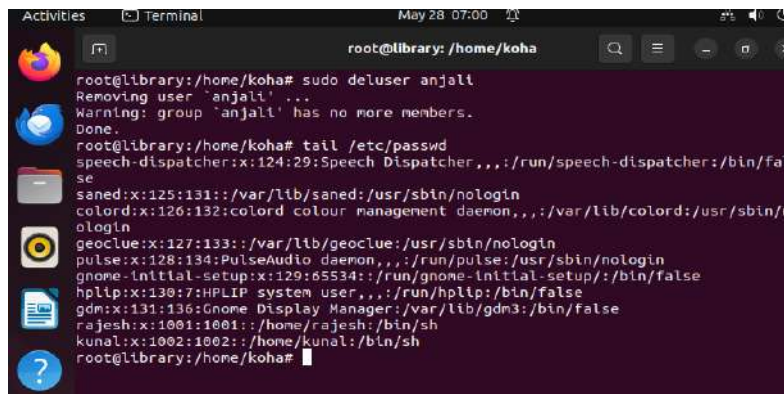

```

root@library: /home/koha# sudo deluser anjall
Removing user 'anjall' ...
Warning: group 'anjall' has no more members.
Done.
root@library: /home/koha# tail /etc/passwd
speech-dispatcher:x:124:29:Speech Dispatcher,,,:/run/speech-dispatcher:/bin/false
saned:x:125:131::/var/lib/saned:/usr/sbin/nologin
colord:x:126:132:colord colour management daemon,,,:/var/lib/colord:/usr/sbin/nologin
geoclue:x:127:133::/var/lib/geoclue:/usr/sbin/nologin
pulse:x:128:134:PulseAudio daemon,,,:/run/pulse:/usr/sbin/nologin
gnome-initial-setup:x:129:65534::/run/gnome-initial-setup:/bin/false
hplip:x:130:7:HPLIP system user,,,:/run/hplip:/bin/false
gdm:x:131:136:Gnome Display Manager:/var/lib/gdm3:/bin/false
rajesh:x:1001:1001::/home/rajesh:/bin/sh
kunal:x:1002:1002::/home/kunal:/bin/sh
root@library: /home/koha#

```

Common Options

Here are some common options you can use with userdel:

- -r, --remove: Remove the user's home directory and mail spool along with the user account.
- -f, --force: Force the removal of the user account, even if the user is currently logged in. This is potentially dangerous and should be used with caution.

Examples

1. Delete a User

To delete a user account without removing the home directory:

```
# sudo userdel username
```

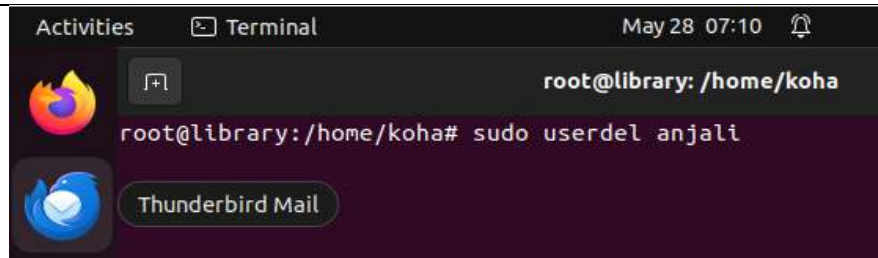

```

Activities Terminal May 28 07:10
root@library: /home/koha
root@library:/home/koha# sudo userdel anjali
Thunderbird Mail

```

2. Delete a User and Remove Home Directory

To delete a user account and remove the home directory and mail spool:

```
# sudo userdel -r username
```

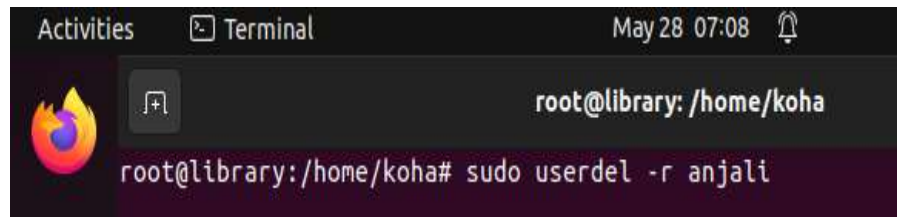

```

Activities Terminal May 28 07:08
root@library: /home/koha
root@library:/home/koha# sudo userdel -r anjali

```

3. Force Delete a User

To force the deletion of a user account (even if the user is currently logged in):

```
# sudo userdel -f username
```

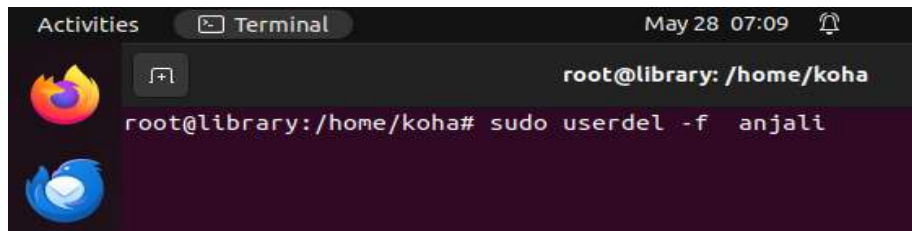

```

Activities Terminal May 28 07:09
root@library: /home/koha
root@library:/home/koha# sudo userdel -f anjali

```

4. Modifying a User

The usermod command in Ubuntu is used to modify an existing user account. This command allows you to change various user account settings such as username, home directory, shell, group memberships, and more. To modify a user's details, use the usermod command. Here are some common options:

Common Options

Here are some common options you can use with usermod:

- l, --login NEW_LOGIN: Change the username of the user.
- d, --home HOME_DIR: Change the user's home directory.
- m, --move-home: Move the contents of the user's home directory to a new location (used with -d).
- s, --shell SHELL: Change the user's login shell.
- c, --comment COMMENT: Change the comment field (typically the user's full name).

-g, --gid GROUP: Change the user's primary group.
-G, --groups GROUP1,GROUP2: Add the user to additional groups.
-a, --append: Add the user to the supplementary groups without removing them from other groups (used with -G).
-L, --lock: Lock the user account.
-U, --unlock: Unlock the user account.
-u, --uid UID: Change the user ID (UID) of the user.
-e, --expiredate EXPIRE_DATE: Set the expiration date for the user account (in YYYY-MM-DD format).
-f, --inactive INACTIVE: Set the number of days after a password expires until the account is permanently disabled.

Change username:

```
# sudo usermod -l new_username old_username
```

Change user's home directory:

```
# sudo usermod -d /new/home/directory -m username
```

Add user to a group:

```
syntax : sudo usermod -aG groupname username
```

5. Managing User Groups

To create a new group, use the addgroup command:

```
# sudo groupadd groupname
```

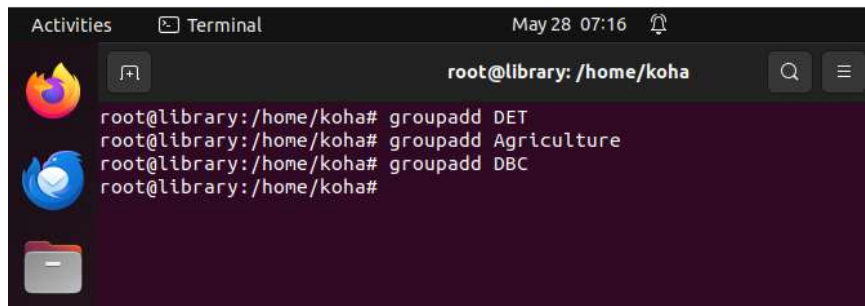

```
Activities Terminal May 28 07:16 root@library: /home/koha  
root@library:/home/koha# groupadd DET  
root@library:/home/koha# groupadd Agriculture  
root@library:/home/koha# groupadd DBC  
root@library:/home/koha#
```

To check the group in ubuntu 24.04 :

```
# tail /etc/group
```

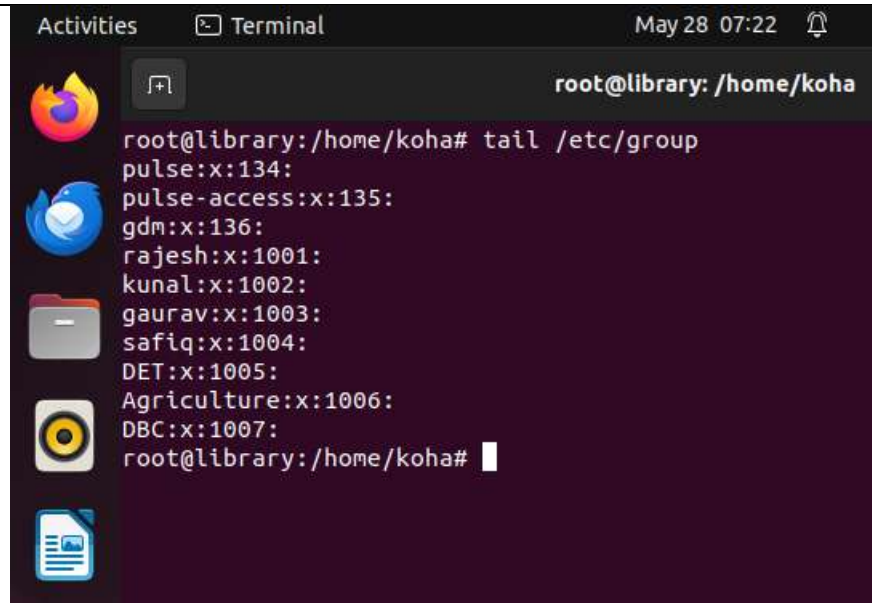

```

Activities Terminal May 28 07:22
root@library: /home/koha

root@library:/home/koha# tail /etc/group
pulse:x:134:
pulse-access:x:135:
gdm:x:136:
rajesh:x:1001:
kunal:x:1002:
gaurav:x:1003:
safiq:x:1004:
DET:x:1005:
Agriculture:x:1006:
DBC:x:1007:
root@library:/home/koha#

```

To add a user to a group:

```
# sudo usermod -G groupname username
```

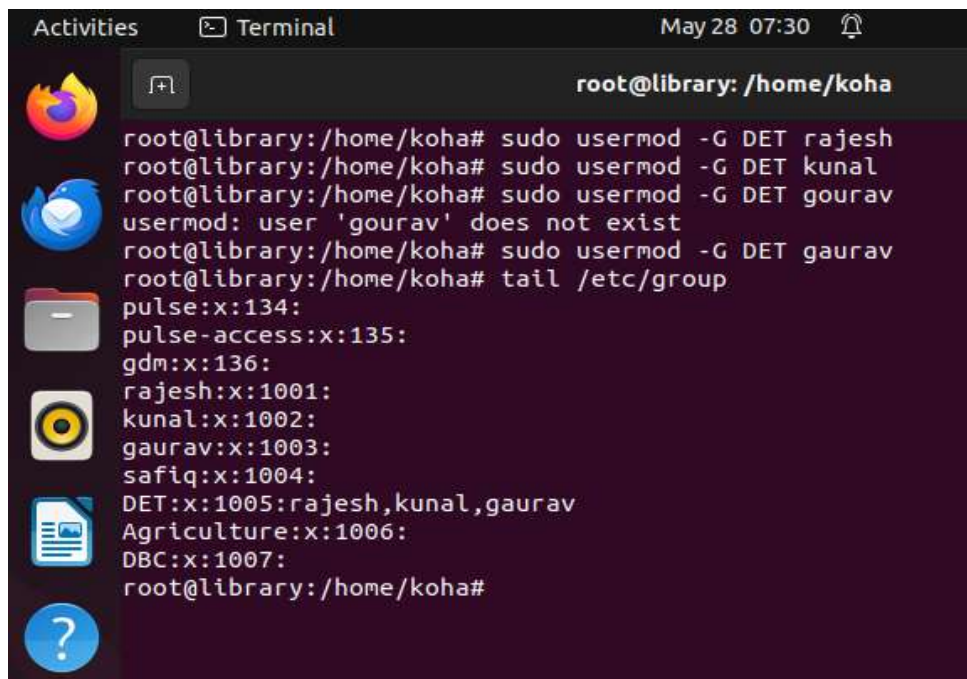

```

Activities Terminal May 28 07:30
root@library: /home/koha

root@library:/home/koha# sudo usermod -G DET rajesh
root@library:/home/koha# sudo usermod -G DET kunal
root@library:/home/koha# sudo usermod -G DET gourav
usermod: user 'gourav' does not exist
root@library:/home/koha# sudo usermod -G DET gaurav
root@library:/home/koha# tail /etc/group
pulse:x:134:
pulse-access:x:135:
gdm:x:136:
rajesh:x:1001:
kunal:x:1002:
gaurav:x:1003:
safiq:x:1004:
DET:x:1005:rajesh,kunal,gaurav
Agriculture:x:1006:
DBC:x:1007:
root@library:/home/koha#

```

To remove a user from a group:

```
# sudo deluser username groupname
```

```

Activities Terminal May 28 07:33
root@library: /home/koha
root@library:/home/koha# sudo deluser gaurav DET
Removing user 'gaurav' from group 'DET' ...
Done.
root@library:/home/koha#

```

6. Changing User Password

To change a user's password, use the passwd command:

syntax: sudo passwd username.

7. Viewing User and Group Information

List all users:

```
# cut -d: -f1 /etc/passwd
```

List all groups:

```
#cut -d: -f1 /etc/group
```

Get user information:

```
# id username
```

8. Locking and Unlocking User Accounts

To lock a user account:

```
#sudo usermod -L username
```

To unlock a user account:

```
# sudo usermod -U username
```

9. Managing Sudo Privileges

To give a user sudo privileges, add the user to the sudo group:

```
# sudo usermod -aG sudo username
```

Overview of the Linux Filesystem :

Understanding the Linux filesystem hierarchy is crucial for effective system administration and usage. The Linux filesystem is organized in a hierarchical structure, starting from the root directory (/). Here's a detailed explanation of the main directories in the Linux filesystem, particularly in Ubuntu, along with a diagram for visualization.

Linux Filesystem Hierarchy

/

|— bin

|— boot

```

├─ dev
├─ etc
├─ home
├─ lib
├─ lib64
├─ media
├─ mnt
├─ opt
├─ proc
├─ root
├─ run
├─ sbin
├─ srv
├─ sys
├─ tmp
├─ usr
└─ var

```

In Linux, all files and devices on the system are organized under the "root" directory, represented by the starting "/". To navigate to the top-level directory of the entire operating system and view its contents, you can type:

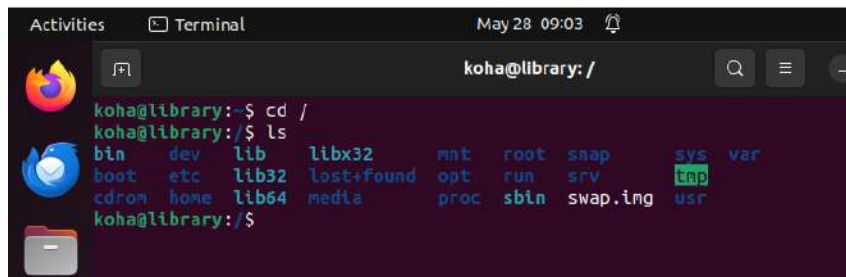

```

Activities Terminal May 28 09:03
koha@library: /
koha@library:~$ cd /
koha@library:/$ ls
bin  dev  lib  lib32  mnt  root  snap  sys  var
boot etc  lib32 lost+found opt  run  srv  tmp
cdrom home lib64 media  proc  sbin  swap.img  usr
koha@library:/$

```

Every file, device, directory, and application is located under this main directory. Here, we can see the start of the entire directory structure. We'll explain more details below:

In Ubuntu 24.04, the filesystem is organized into a hierarchical structure, starting from the root directory (/). Here's a brief overview of the main directories you'll find:

1. / (Root Directory): At the core of the filesystem hierarchy is the primary root directory. Every file and directory stems from this root directory. Only the root user possesses the authority to write directly within this directory. However, it's essential to note that /root is the designated home directory for the root user, distinct from the primary root directory.

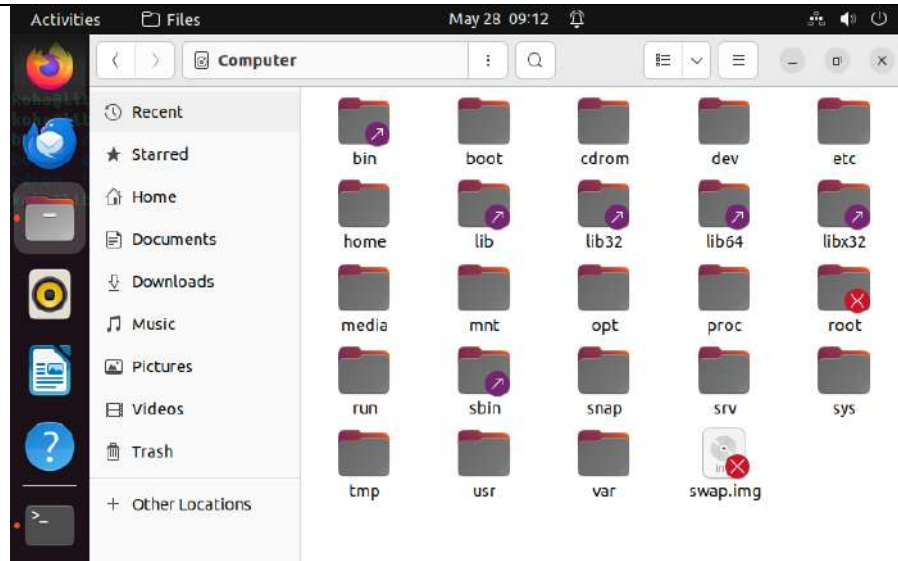

2. `/bin`: This directory houses essential command binaries necessary for single-user mode and universally required commands, such as `cat`, `ls`, and `cp`. It stores binary executables, including common Linux commands needed in single-user mode. These commands, utilized by all system users, encompass functions like `ps`, `ls`, `ping`, `grep`, and `cp`.

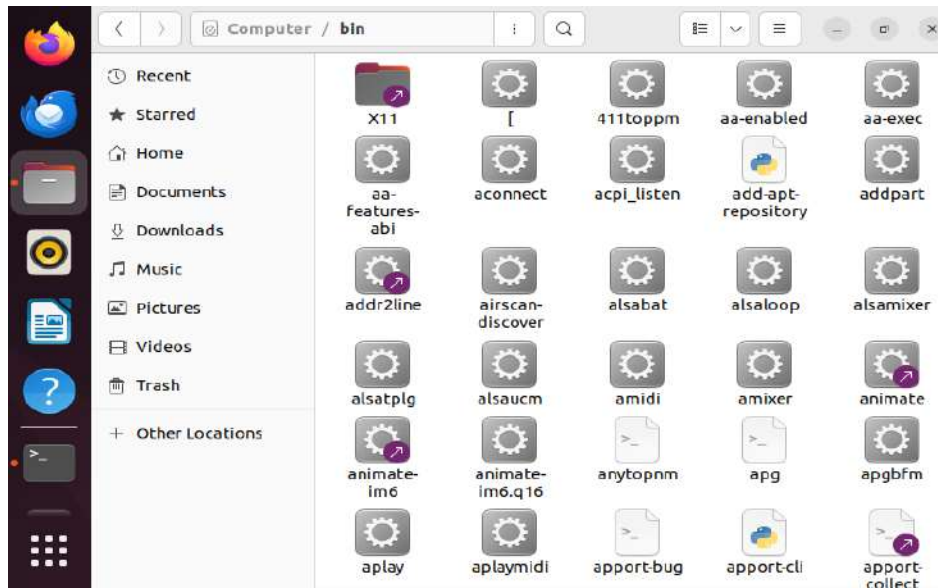

3. `/boot`: This directory houses boot loader files, including kernels and `initrd`. You can find essential boot files such as kernel `initrd`, `vmlinuz`, and `grub` files under `/boot`. For instance, examples include `initrd.img-2.6.32-24-generic` and `vmlinuz-2.6.32-24-generic`.

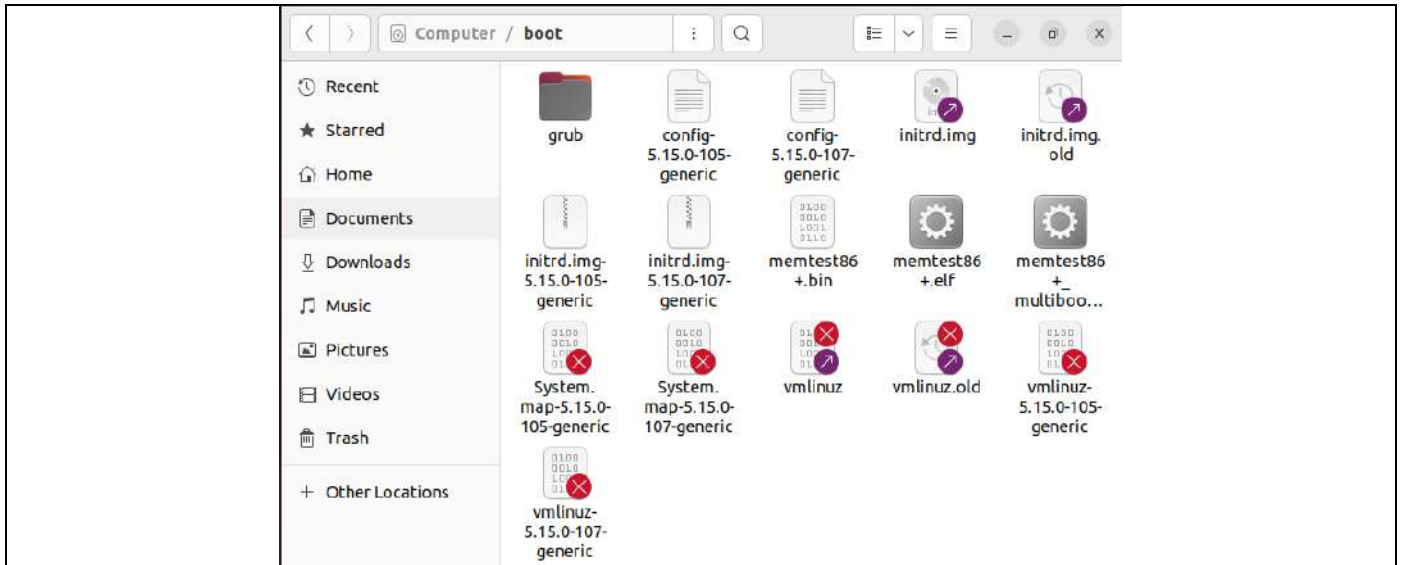

4. `/dev`: These files are essential for devices, including terminals, USB devices, and any hardware attached to the system. You'll find terminal devices like `/dev/tty1` and USB monitoring devices like `/dev/usbmon0` here, along with other device files such as `/dev/null`.

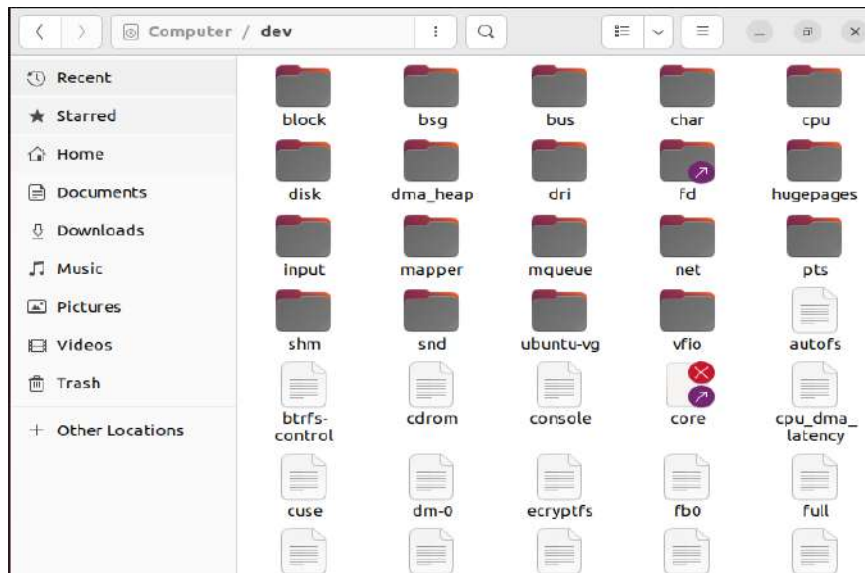

5. `/etc`: These files store host-specific system-wide configuration settings, necessary for all programs running on the system. Additionally, you'll find startup and shutdown shell scripts used to manage individual programs. Examples include `/etc/resolv.conf` and `/etc/logrotate.conf`.

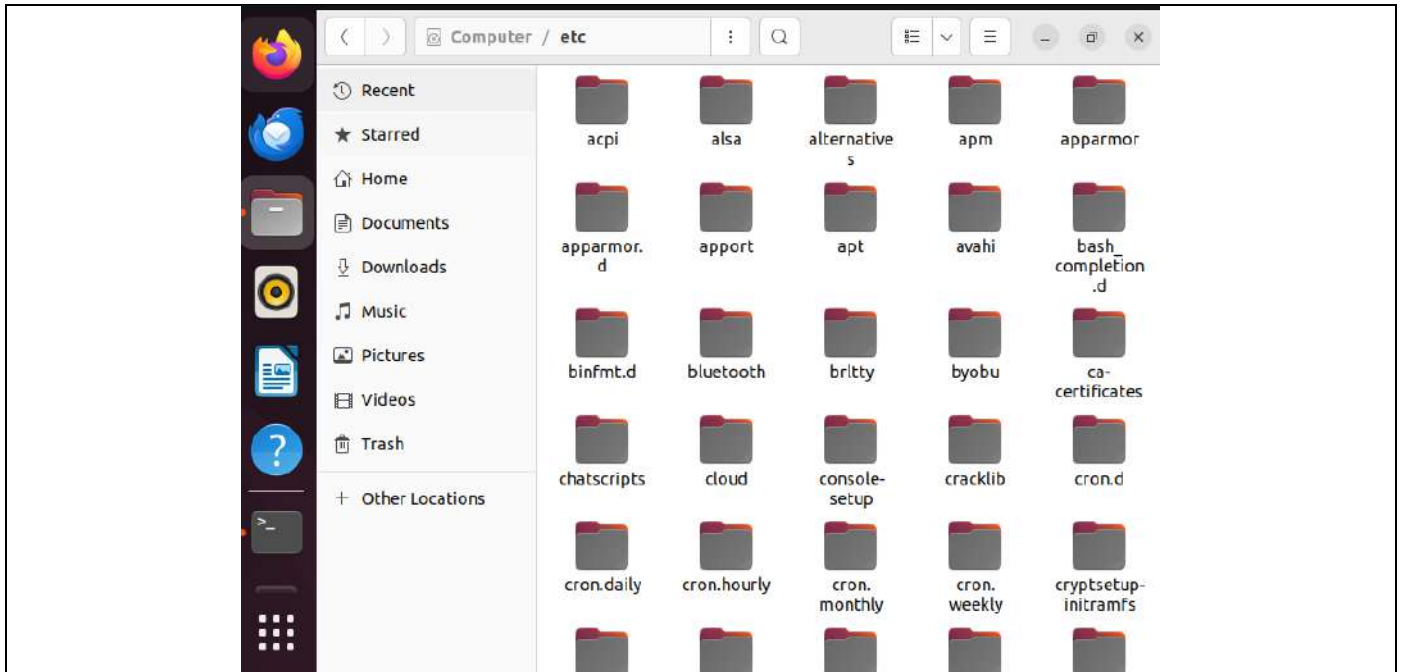

6. /home: These directories serve as the home for users, storing their personal files, preferences, and configurations. Each user has their own home directory within /home, like /home/koha and /home/koha.

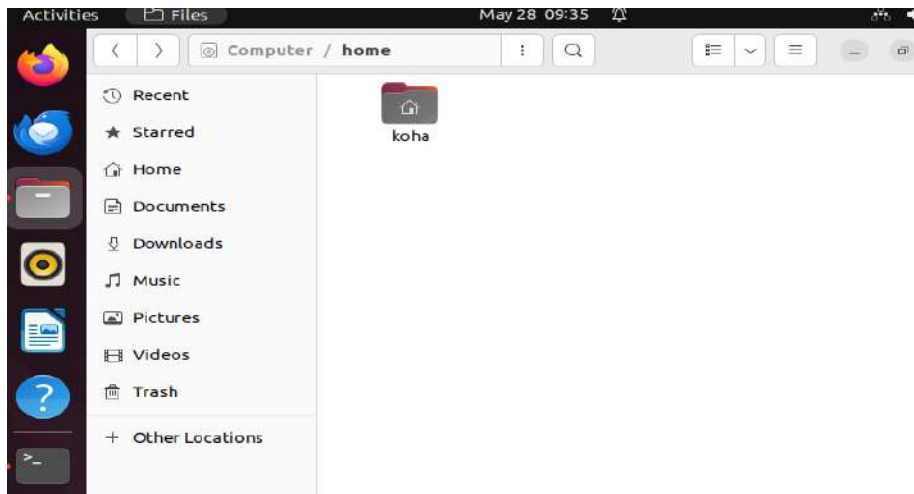

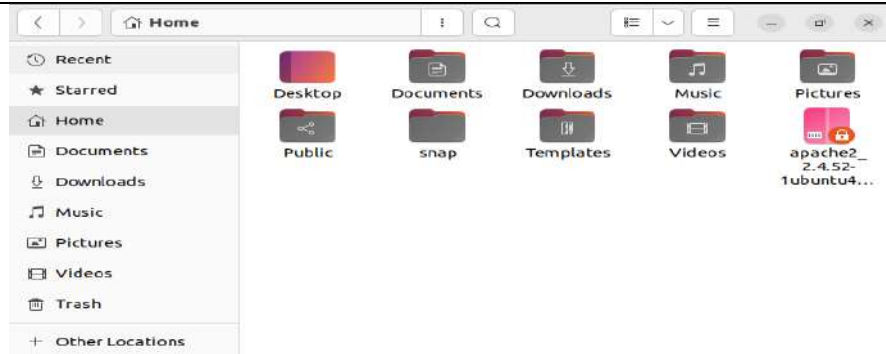

7. /lib: These directories hold vital libraries required by executables in /bin/ and /sbin/. Library filenames often start with ld* or lib*.so.*, such as ld-2.11.1.so and libncurses.so.5.7.

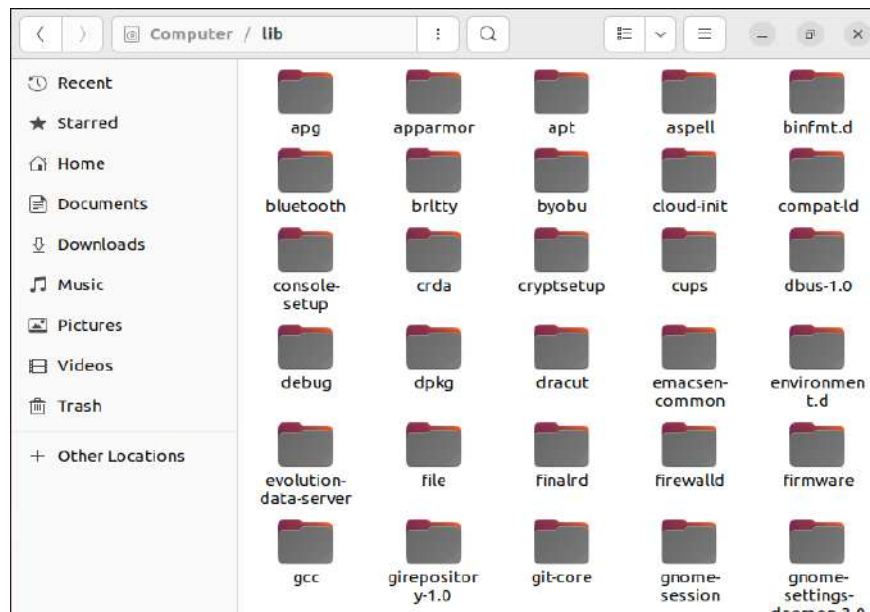

8. /lib64: Contains 64-bit libraries.

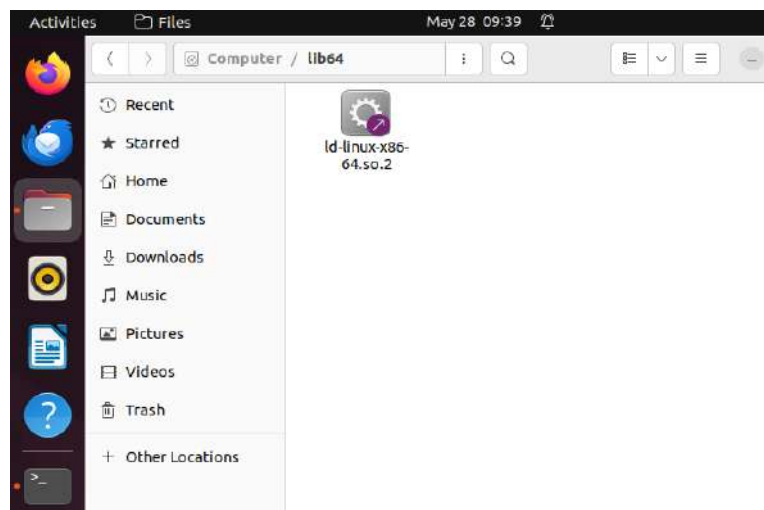

9. /media: These directories serve as mount points for removable media like CD-ROMs, introduced in FHS-2.3. They act as temporary mount locations for various devices, for instance, /media/cdrom for CD-ROMs, /media/floppy for floppy drives, and /media/cdrecorder for CD writers.

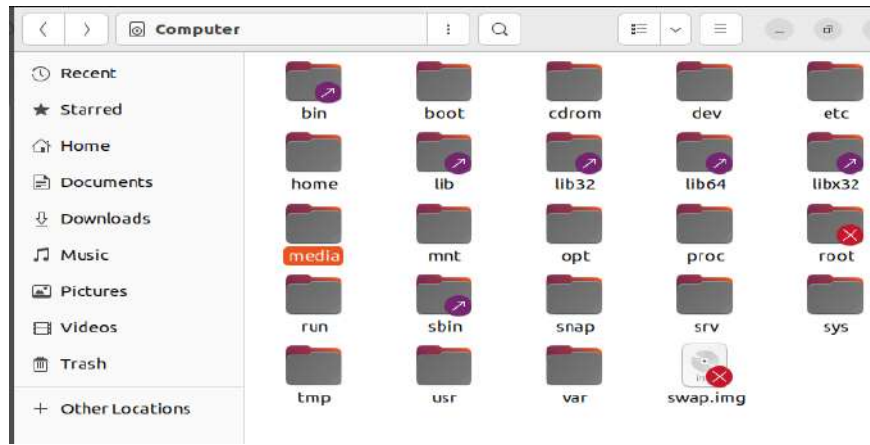

10. /mnt: This directory serves as a temporary mount location for filesystems, where system administrators can mount filesystems as needed.

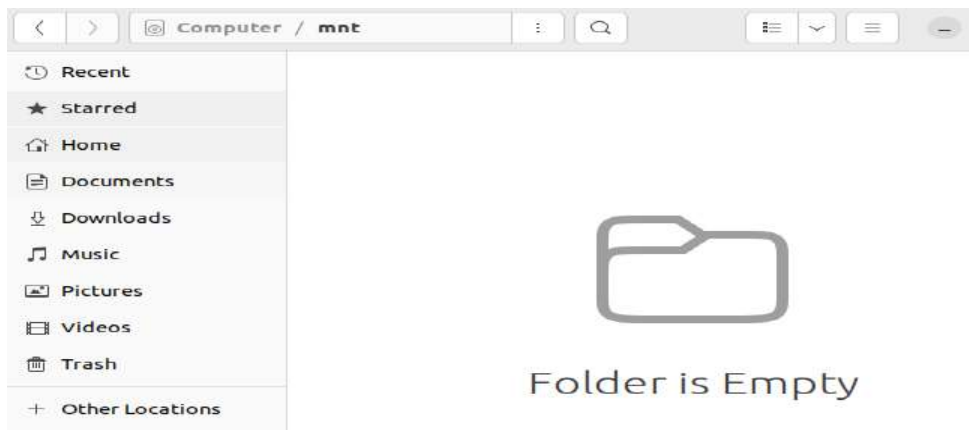

11. /opt: Directory for installing optional software packages.

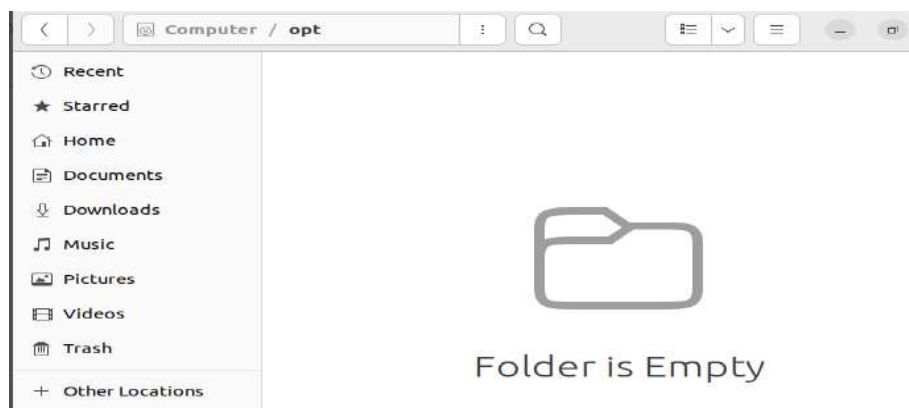

12. /proc: This directory houses optional application software packages, including add-on applications provided by various vendors. Add-on applications should be installed either directly under /opt/ or within sub-directories of /opt/.

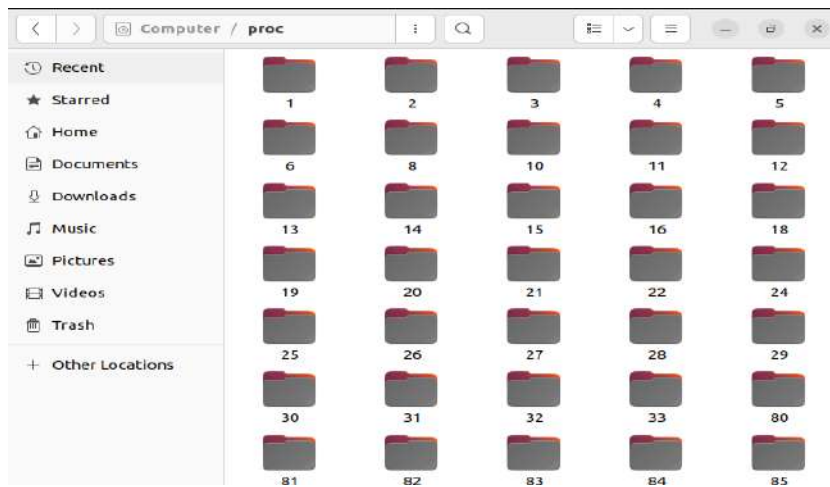

13. /run: Holds temporary data about the system since it was booted.

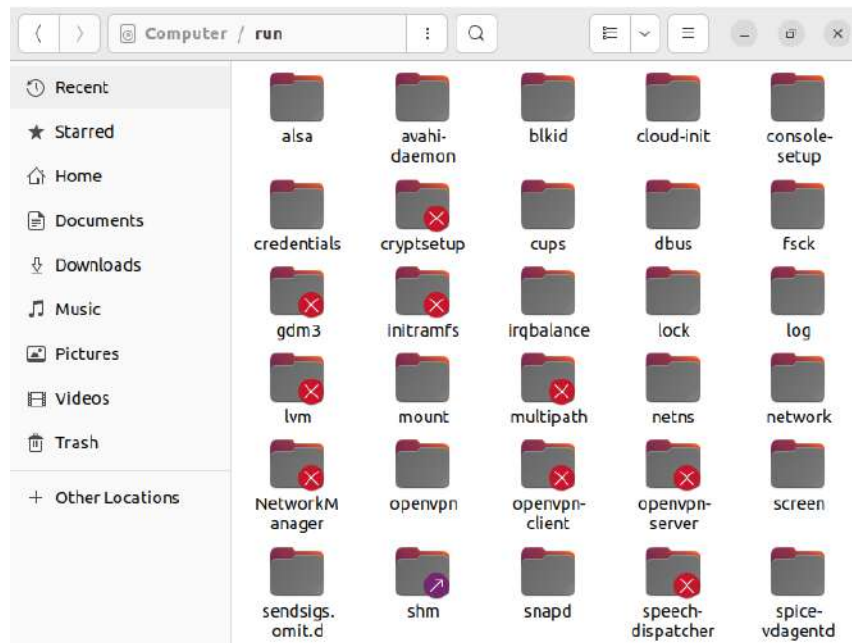

14. /sbin: Contains essential system binaries typically used by the system administrator.

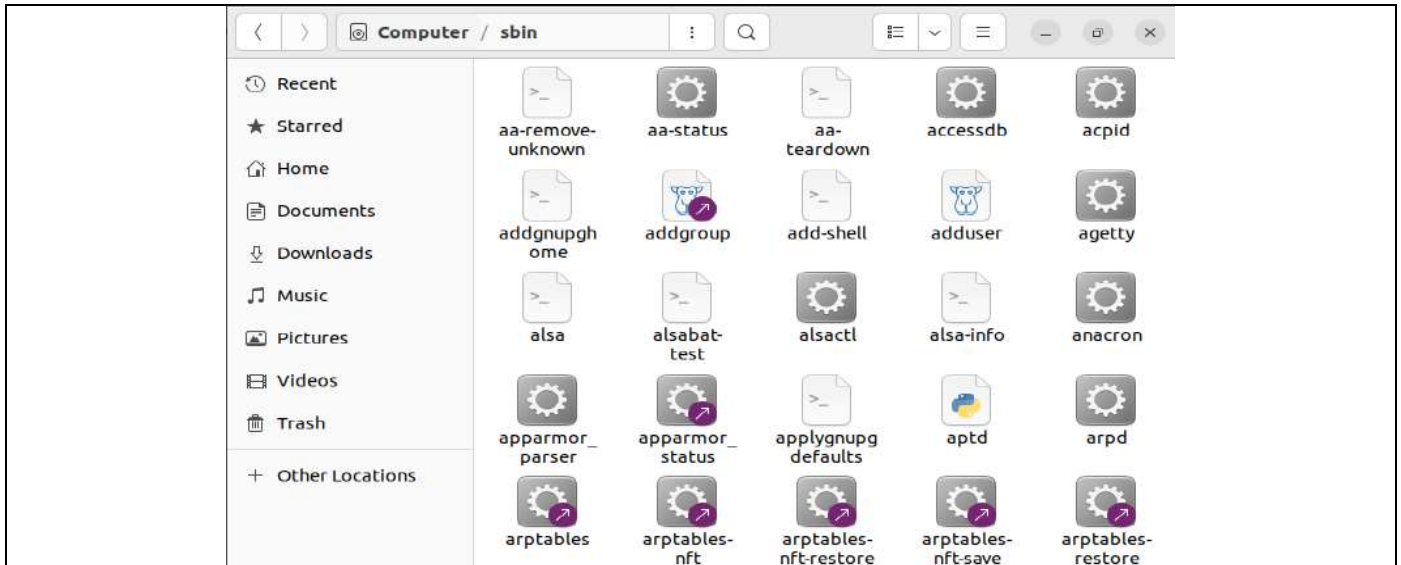

15. /srv: Contains data for services provided by the system, like web server files.

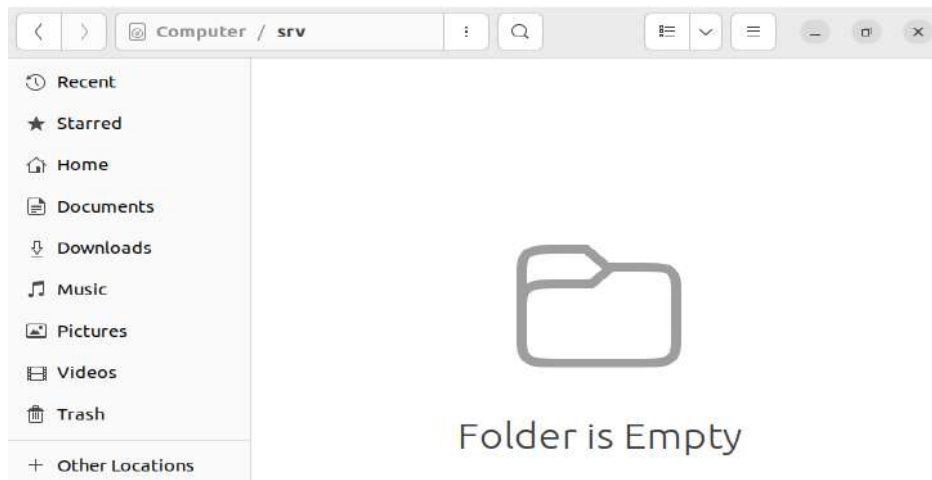

16./sys: Another virtual filesystem, providing information about the system and hardware devices.

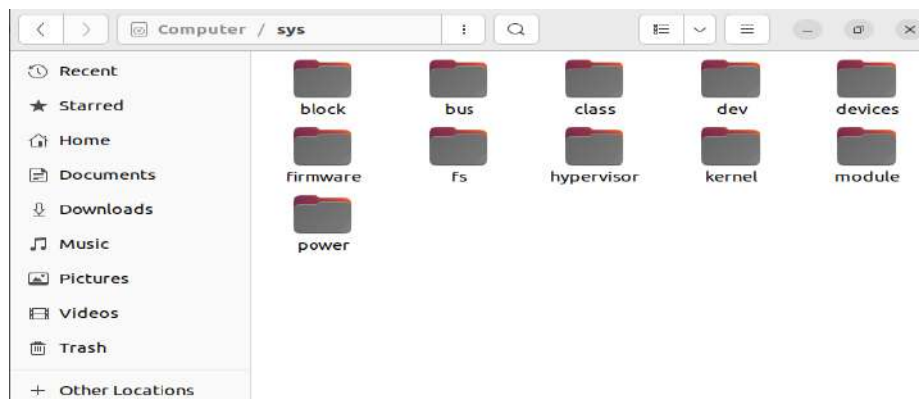

17. /tmp: Directory for temporary files, often cleared on reboot.

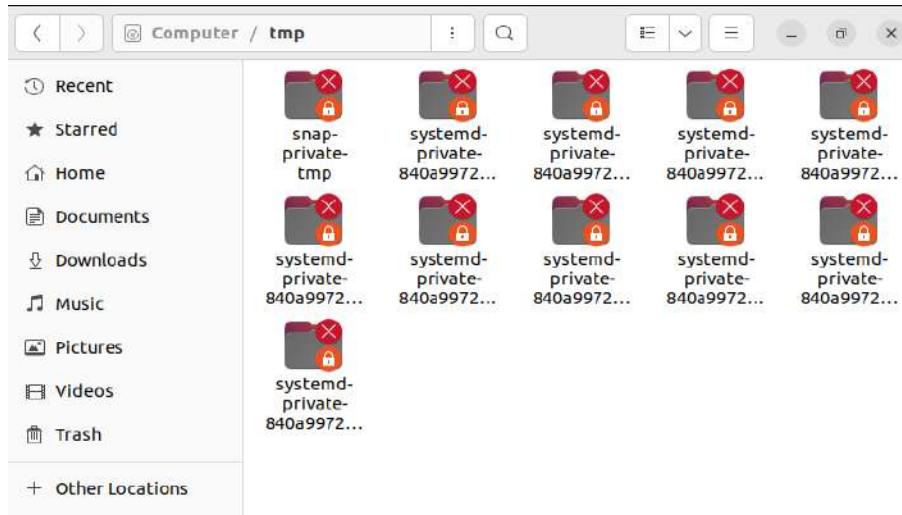

18./usr: This directory serves as a secondary hierarchy for read-only user data, housing the majority of multi-user utilities and applications. It encompasses binaries, libraries, documentation, and source code for second-level programs. Here are some key components:

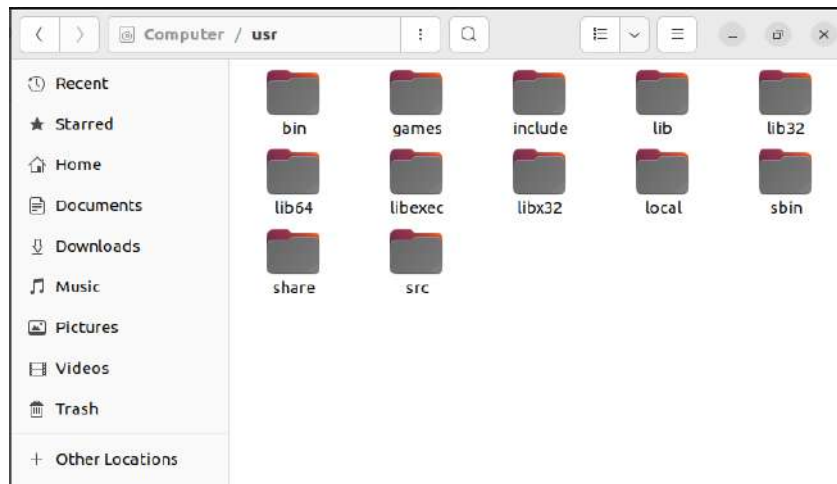

19./usr/bin: Holds binary files for user programs. If a user binary isn't found under /bin, it's typically located here. Examples include at, awk, cc, less, and scp.

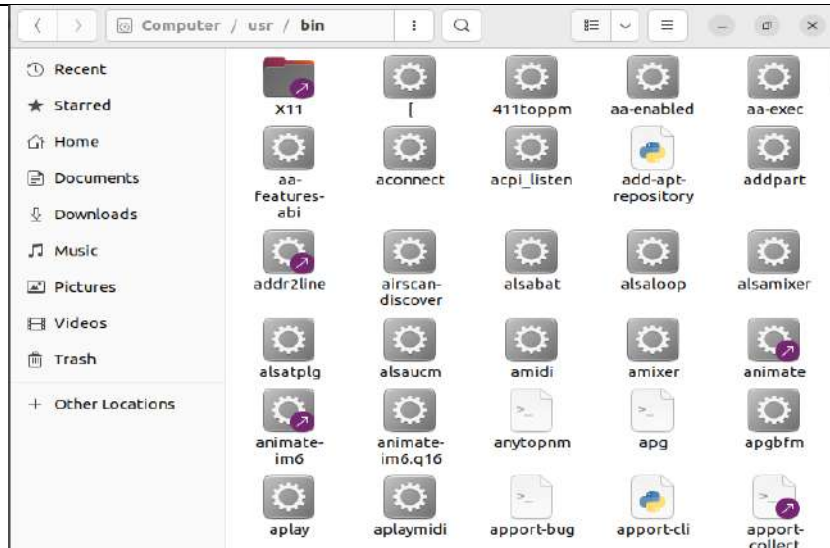

20./usr/sbin: Contains binary files for system administrators. If a system binary isn't found under /sbin, it's usually located here. Examples include atd, cron, sshd, useradd, and userdel.

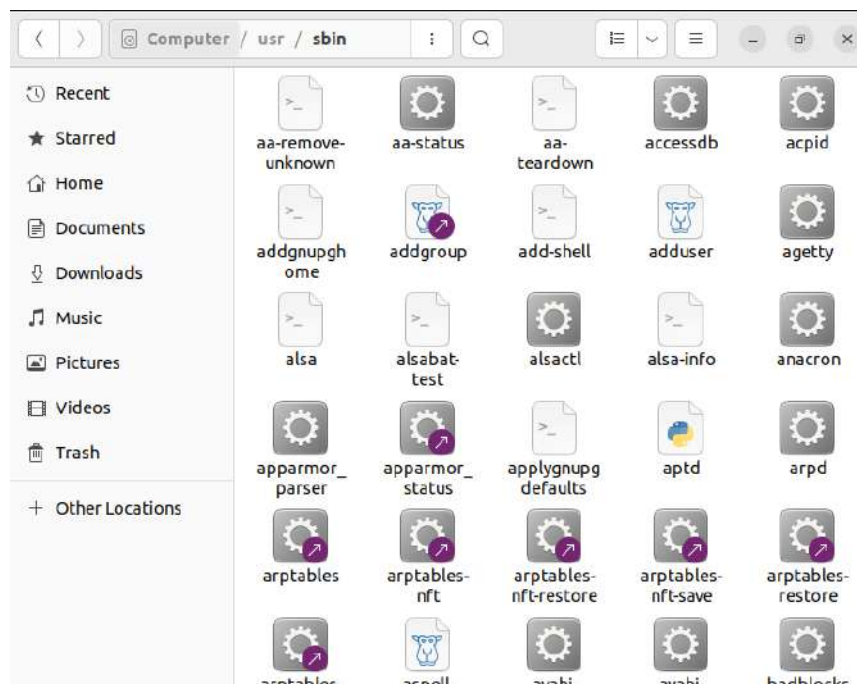

21./usr/lib: Houses libraries for /usr/bin and /usr/sbin.

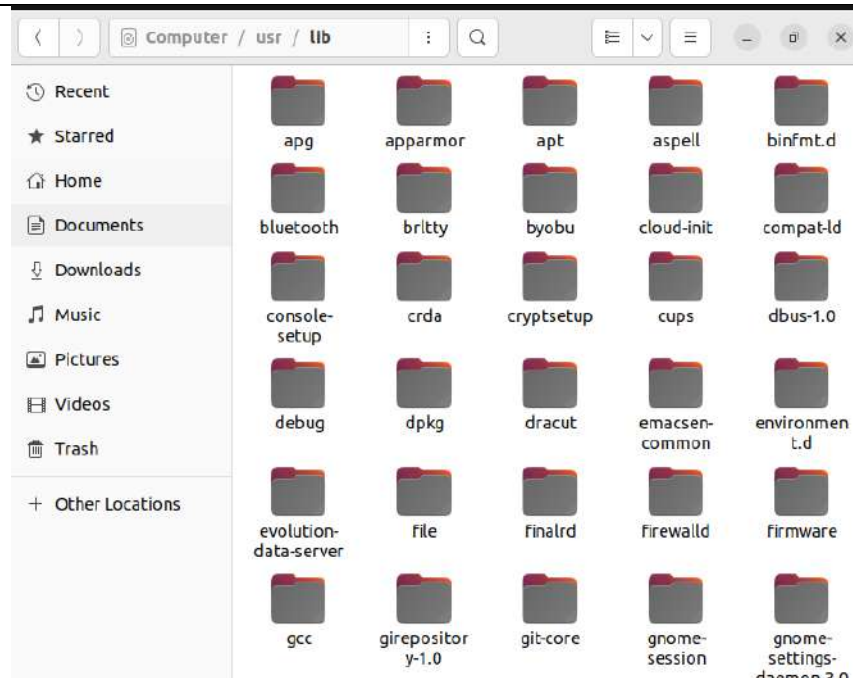

22./usr/local: Stores user programs installed from source. For instance, when you install Apache from source, it's placed under /usr/local/apache2.

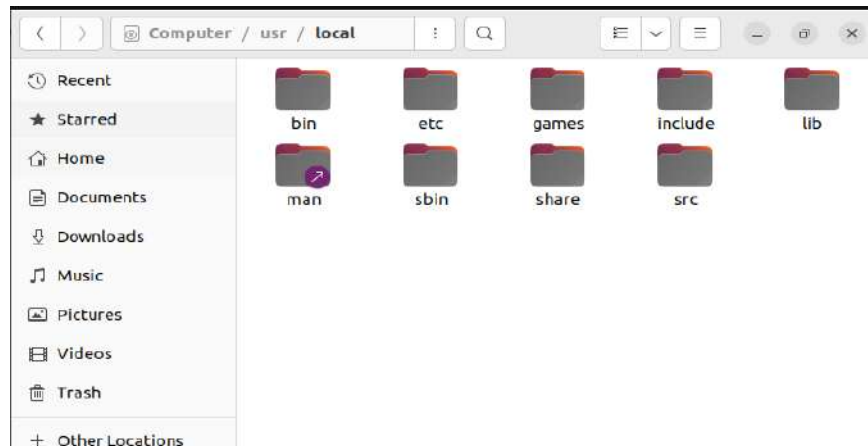

23./usr/src: Holds Linux kernel sources, header files, and documentation.

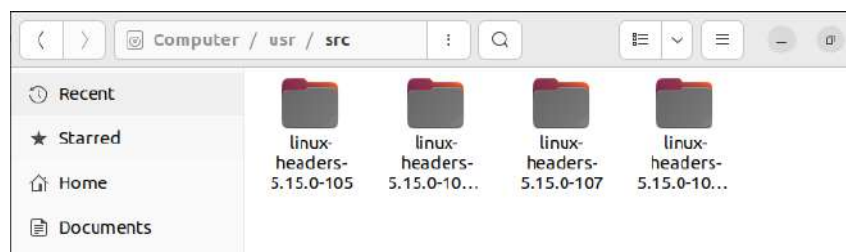

24./var: Contains variable data like logs, spool files, and temporary files used by the system.

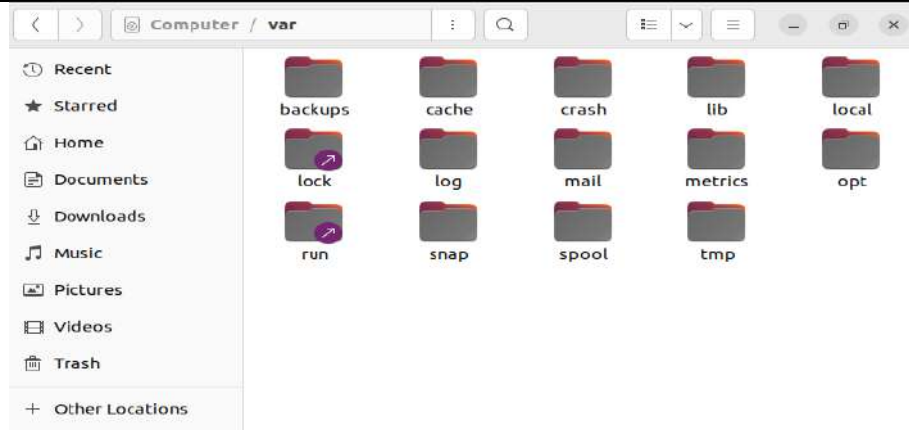

Disk Management in Linux:

Disk management in Linux involves a variety of tools and commands for handling disk partitions, file systems, and other storage-related tasks. Below is an overview of key concepts and commonly used tools for managing disks in Linux.

Key Concepts

1. Partitions: Dividing a disk into separate sections that can be managed independently.
2. File Systems: Formats that define how data is stored and retrieved on a partition.
3. Mounting: Making a file system accessible at a certain point in the directory tree.
4. Logical Volume Management (LVM): A method of managing disk space more flexibly than traditional partitioning.

Common Tools and Commands Viewing Disk Information

1. lsblk: Lists all block devices.

Syntax :lsblk

```
koha@library: ~
koha@library:~$ lsblk
NAME        MAJ:MIN RM  SIZE RO TYPE MOUNTPOINTS
loop0       7:0    0     4K  1 loop /snap/bare/5
loop1       7:1    0   63.9M  1 loop /snap/core20/2105
loop2       7:2    0   63.9M  1 loop /snap/core20/2318
loop3       7:3    0   74.2M  1 loop /snap/core22/1122
loop4       7:4    0  270.7M  1 loop /snap/firefox/4259
loop5       7:5    0   74.2M  1 loop /snap/core22/1380
loop6       7:6    0  505.1M  1 loop /snap/gnome-42-2204/176
loop7       7:7    0  269.6M  1 loop /snap/firefox/4136
loop8       7:8    0   91.7M  1 loop /snap/gtk-common-themes/1535
loop9       7:9    0   12.9M  1 loop /snap/snap-store/1113
loop10      7:10   0   10.4M  1 loop /snap/snap-store/1134
loop11      7:11   0    87M  1 loop /snap/lxd/27037
loop12      7:12   0   40.4M  1 loop /snap/snapd/20671
loop13      7:13   0    87M  1 loop /snap/lxd/28373
loop14      7:14   0   38.8M  1 loop /snap/snapd/21759
sda         8:0    0  155G  0 disk
├─sda1      8:1    0     1M  0 part
├─sda2      8:2    0     2G  0 part /boot
└─sda3      8:3    0   153G  0 part
   └─ubuntu--vg-ubuntu--lv
      253:0   0  76.5G  0 lvm  /var/snap/firefox/common/host-hunspell
sr0        11:0   1 1024M  0 rom
koha@library:~$
```

2. fdisk: A command-line utility for partitioning disks. Use -l to list partitions.

```
# sudo fdisk -l
```

```
koha@library:~$ sudo fdisk -l
[sudo] password for koha:
Disk /dev/loop0: 4 KiB, 4096 bytes, 8 sectors
Units: sectors of 1 * 512 = 512 bytes
Sector size (logical/physical): 512 bytes / 512 bytes
I/O size (minimum/optimal): 512 bytes / 512 bytes

Disk /dev/loop1: 63.91 MiB, 67014656 bytes, 130888 sectors
Units: sectors of 1 * 512 = 512 bytes
Sector size (logical/physical): 512 bytes / 512 bytes
I/O size (minimum/optimal): 512 bytes / 512 bytes

Disk /dev/loop2: 63.95 MiB, 67051520 bytes, 130960 sectors
Units: sectors of 1 * 512 = 512 bytes
Sector size (logical/physical): 512 bytes / 512 bytes
I/O size (minimum/optimal): 512 bytes / 512 bytes

Disk /dev/loop3: 74.21 MiB, 77819904 bytes, 151992 sectors
Units: sectors of 1 * 512 = 512 bytes
Sector size (logical/physical): 512 bytes / 512 bytes
I/O size (minimum/optimal): 512 bytes / 512 bytes

Disk /dev/loop4: 270.74 MiB, 283893760 bytes, 554480 sectors
Units: sectors of 1 * 512 = 512 bytes
Sector size (logical/physical): 512 bytes / 512 bytes
```

3. parted: A more advanced disk partitioning tool.

```
# sudo parted /dev/sda
```

```
koha@library:~$ sudo parted /dev/sda
GNU Parted 3.4
Using /dev/sda
Welcome to GNU Parted! Type 'help' to view a list of commands.
(parted) █
```

4. df: Displays disk space usage of file systems.

```
# df -h
```

```
koha@library:~$ df -h
Filesystem      Size  Used Avail Use% Mounted on
tmpfs           485M  1.5M  483M   1% /run
/dev/napper/ubun 75G   12G   60G  17% /
tmpfs           2.4G   0    2.4G   0% /dev/shm
tmpfs           5.0M  4.0K  5.0M   1% /run/lock
/dev/sda2       2.0G  264M  1.6G  15% /boot
tmpfs           485M  104K  485M   1% /run/user/1000
koha@library:~$
```

5. du: Shows disk usage of files and directories.

```
# du -sh /path/to/directory
```

Mounting and unmounting file system in ubuntu

You can mount file systems for a single session using the mount command, or permanently by editing the /etc/fstab file. Mounting requires administrative privileges, which can be obtained

by logging in as the root user or by using the sudo command. In some instances, such as when inserting a USB flash drive, the system handles mounting automatically. Below are examples demonstrating the use of the mount command, along with the mkdir command to create the necessary mount point.

1. Mount a Windows Floppy Disk

First, create the mount point directory if it doesn't already exist:

```
# mkdir /mnt/floppy
```

Next, use the mount command with the -t flag (short for "type") to specify msdos as the file system:

```
# mount -t msdos /dev/fd0 /mnt/floppy
```

Now, the contents of the floppy disk in /dev/fd0 should be accessible from /mnt/floppy.

2. Mount a CD-ROM

First, create the mount point directory if it doesn't already exist:

```
# mkdir /mnt/cdrom
```

Next, mount the CD-ROM. Specifying the -t iso9660 option is usually unnecessary since Linux can automatically detect the file system type:

```
# mount /dev/cdrom /mnt/cdrom
```

The contents of the CD-ROM in /dev/cdrom should now be accessible from /mnt/cdrom.

Unmount files system

You can unmount a file system using the umount command. You can specify either the device name or the mount point to indicate what you wish to unmount:

```
umount /media/nfs
```

```
umount /media/iso
```

```
umount /media/usb
```

```
umount /dev/cdrom
```

```
umount /dev/fd0
```

If the file system is in use, you will receive an error message indicating that the target is busy. To identify which processes are using the mounted file system, use the fuser -m command, for example:

```
# fuser -m /media/usb
```

To unmount a device when it is free, you can use the -l (lazy) switch with umount. Alternatively, the -f (force) switch forces the system to unmount the device immediately, though this can risk corrupting the file system. The -f switch is mainly intended for unmounting unreachable NFS shares.

Demonstrate to install Printer in Ubuntu Linux

<https://engineering.purdue.edu/ECN/Support/KB/Docs/VPSPrinterUbuntu>

Activity 1

Practical Activity 3.1: How to install Printer in Ubuntu Linux 24.04 LTS.

Adding a printer in Ubuntu 24.04 can be done through the graphical user interface (GUI) or the command line. Here's a step-by-step guide for both methods:

Step 1. Open Settings:

Click on the system menu (top-right corner) and select "Settings".

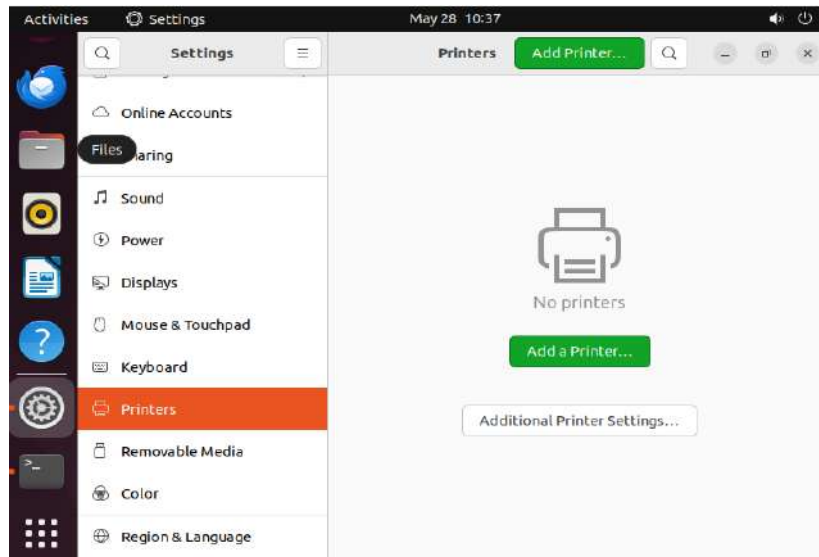

Step 2. Go to Printers:

In the Settings window, find and click on "Printers".

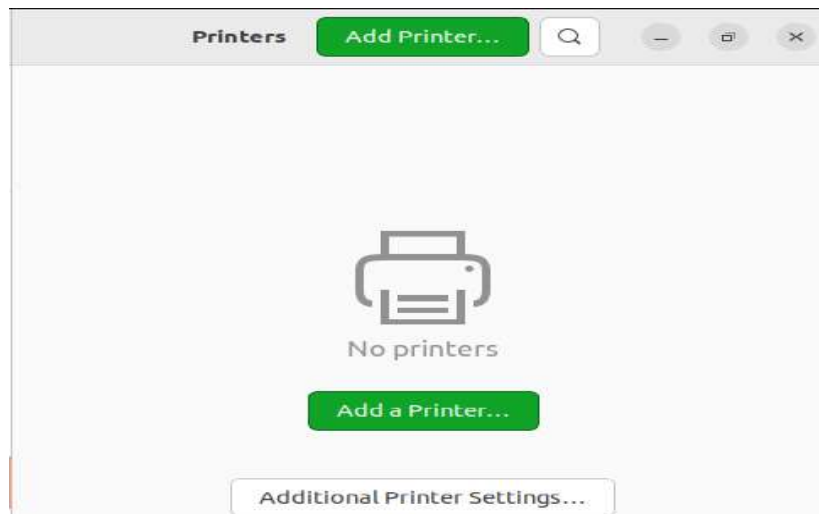

Step 3. Add a Printer:

Click the "Add" button (usually represented by a "+" sign).

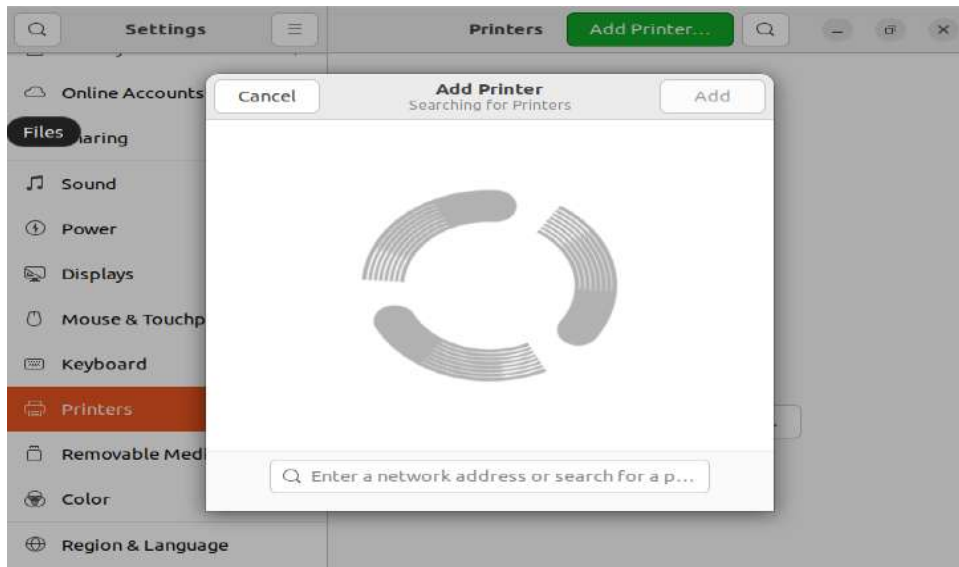

Step 4. Select Your Printer:

Ubuntu will search for available printers. Select your printer from the list. If your printer is connected via USB, it should appear automatically. For network printers, you may need to click "Network Printer" and enter the necessary details.

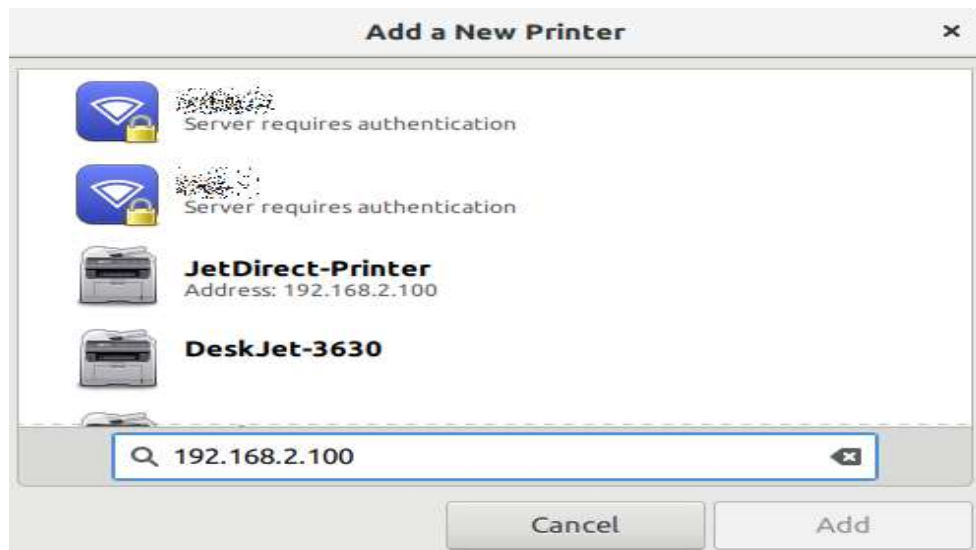

Step 5. Install Printer Driver:

If prompted, choose the appropriate driver for your printer. Ubuntu usually installs the correct driver automatically, but you may need to select it manually.

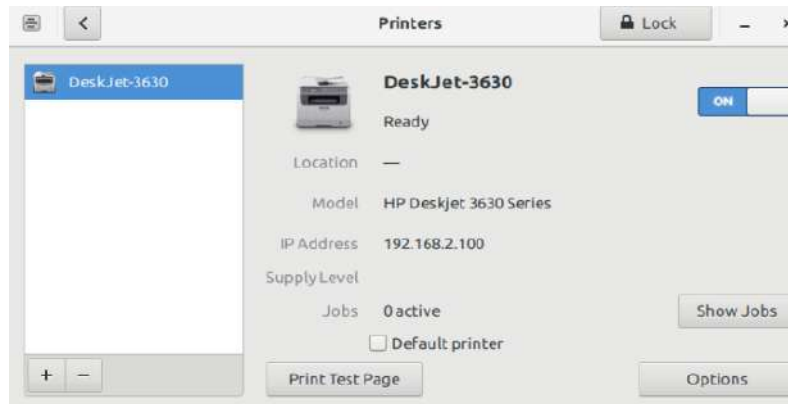

Step 6. Finish Setup:

Follow the on-screen instructions to complete the setup. You can name your printer, set it as the default printer, and print a test page to ensure it's working correctly.

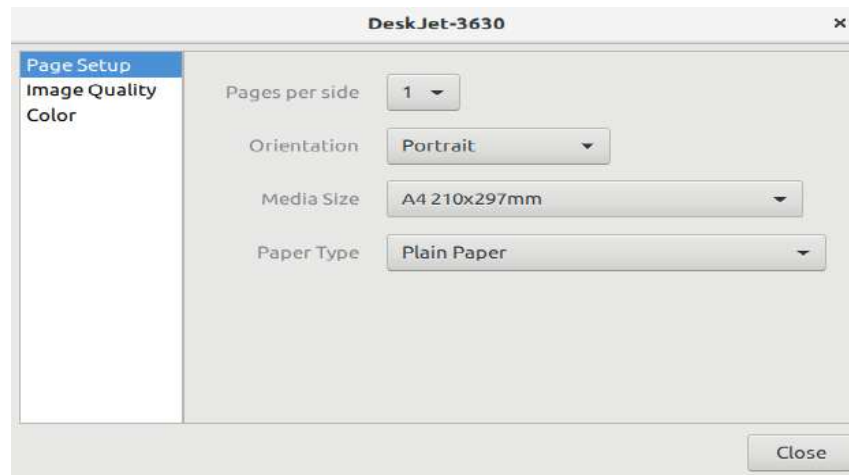

Summary

In Linux, while installing and setting up printers, scanners, and other peripheral devices, drivers may need to be downloaded or system settings adjusted. This process ensures that all devices function properly.

Check Your Progress

A. Maniple choice questions

1. Which is an example of an input device? (a) Printer (b) Display (c) Keyboard (d) Speaker
2. Which device provides a graphical interface for the user to interact with the system? (a) Monitor (b) Mouse (c) Scanner (d) Printer
3. Microphones are classified as: (a) Output devices (b) Storage devices (c) Input devices (d) Networking devices

4. Which is not an output device? (a) Scanner (b) Speaker (c) Printer (d) Display
5. Peripheral devices enhance system functionality by providing: (a) Input (b) Output (c) Both input and output (d) Storage only

B. Fill in the Blanks

1. _____ allows users to input text and commands to the computer.
2. _____ converts physical documents into digital format.
3. _____ produces hard copies of digital documents.
4. _____ outputs audio for music and videos.
5. _____ presents visual output on a screen.

C. True or False

1. Peripheral devices are essential for basic computer operation.
2. Printers are classified as output devices.
3. A mouse only provides audio output.
4. Scanners convert digital documents back to physical copies.
5. User management in Ubuntu involves managing user permissions and groups.

D. Short Questions

1. Define a peripheral device.
2. Give two examples each of input and output devices.
3. How do peripheral devices enhance the user experience?
4. What is the command to add a new user in Ubuntu?
5. Name a command for checking disk space usage in Ubuntu.

Glossary

- Computer: An automatic machine that performs calculations
- Data: Information or facts
- Process: Handling or processing of information
- Output: Result produced by the computer
- Motherboard: The board that connects all components
- CPU (Central Processing Unit): The central unit that processes data
- RAM (Random Access Memory): Temporary memory for quick data access
- Hard Disk: Permanent data storage device

- Input Device: Device used to provide information to the computer
- Output Device: Device that displays or provides information
- Keyboard: Device used for typing
- Monitor: Device that displays output on the screen
- Storage Device: Device used to store data
- Peripheral Device: Supporting or auxiliary device
- Pen Drive: Portable storage device
- Printer: Device used for printing
- Operating System: Software that manages computer operations
- Software: Program that runs or controls the computer
- Interface: Means of communication between user and system
- File Management: Organizing and handling of files
- Installation: Process of setting up software
- Bootable Device: Device used to start the system
- User Account: Profile of a computer user
- Settings: Configuration options
- Configuration: Arrangement or setup of system components
- Network Setup: Connecting to the internet or network
- Display Settings: Screen-related options
- Application: Program designed to perform a task
- Linux: Free and open-source operating system
- Ubuntu: A popular version of Linux
- Bootable USB: USB used to start or install a program
- Installation: Process of installing software or OS
- Post-Installation: Tasks performed after installation
- Update: Getting the latest version
- Security: Protection against threats
- Application: Software program for performing specific tasks
- Driver: Program that operates hardware devices
- Setup: Initial preparation or arrangement
- Peripheral: Auxiliary or external device
- Scanner: Device that converts paper documents into digital form

Answers**Module 1—Fundamentals of Computers and Peripherals****Session 1: Basic Functionality of Computer Systems****Check Your Progress****A. Multiple Choice Questions**

1. (d) 2. (b) 3. (c) 4. (b) 5. (a)

B. Fill in the Blanks

1. Compute 2. Mark I 3. Central Processing Unit (CPU) 4. Bytes, KB, MB, GB, TB 5. Supercomputer

C. True or False

1. True 2. False 3. False 4. True 5. False

Session 2—Internal Components of a Computer**Check Your Progress****A. Multiple Choice Questions**

1. (b) 2. (a) 3. (b) 4. (c) 5. (d)

B. Fill in the Blanks

1. Motherboard 2. ALU 3. ROM 4. Graphics 5. Sound

C. True or False

1. True 2. False 3. True 4. False 5. True

Session 3— Input and Output Devices Check Your Progress**A. Multiple Choice Questions**

1. (b) 2. (c) 3. (c) 4. (b) 5. (b) 6. (c) 7. (d)

B. Fill in the Blanks

1. Keyboard 2. Pointing Device 3. Camera 4. Input Card Reader 5. Scanner 6. Output Device 7. Monitor 8. Speaker

C. True or False

1. False 2. True 3. True 4. False 5. True 6. False 7. True 8. False

Session 4— Storage and Peripheral Devices**Check Your Progress****A. Multiple Choice Questions**

1. (d) 2. (a) 3. (b) 4. (c) 5. (c) 6. (b) 7. (d) 8. (c) 9. (a) 10. (c)

B. True or False

1. False 2. True 3. False 4. False 5. True 6. True 7. False 8. True 9. True 10. True

C. Fill in the Blanks

1. Primary Memory (RAM) 2. Secondary Memory 3. Floppy Disk 4. Optical Disk 5. Hard Disk Drive 6. CD/DVD 7. Hard Disk Drive 8. Disk Drive Performance 9. SATA and SCSI Interfaces

Module 2—Installation and Configuration of Windows Operating System**Session 1—Operating System Fundamentals****Check Your Progress****A. Multiple Choice Questions**

1. (c) 2. (c) 3. (b) 4. (c) 5. (b) 6. (d) 7. (b) 8. (c)

B. Fill in the Blanks

1. Operating System 2. Hardware 3. Operating System 4. Memory 5. Process 6. Graphical User

C. True or False

1. False 2. True 3. False 4. True 5. True 6. True

Session 2— Installing Windows Operating System**Check Your Progress****A. Multiple Choice Questions**

1. (b) 2. (c) 3. (b) 4. (b) 5. (a) 6. (c) 7. (a) 8. (d) 9. (b)

B. Fill in the Blanks

1. 1985 2. 2 3. Media Creation 4. Delete 5. BIOS/UEFI 6. Start 7. Cortana

C. True or False

1. True 2. False 3. False 4. True 5. True 6. True 7. True 8. False

Session 3— Configuring Windows Operating System**Check Your Progress****A. Multiple Choice Questions**

1. (d) 2. (c) 3. (a) 3. (c) 4. (a) 5. (b) 6. (b) 7. (b) 8. (c) 9. (b)

B. Fill in the Blanks

1. Display Settings 2. Settings 3. Taskbar 4. Software 5. Windows 6. Quick 7. Settings 8. Network 9. Backup

C. True or False

1. True 2. False 3. True 4. False 5. False 6. True 7. False 8. True 9. True 10. False

Module 3—Installation and Configuration of Linux Operating System**Session 1—Installing Ubuntu Linux****Check Your Progress****A. Multiple Choice Questions**

1. (a) 2. (c) 3. (c) 4. (a) 5. (d)

B. Fill in the Blanks

1. Open-Source 2. Five 3. Virtualization 4. Ubuntu 5. RAM

C. True or False

1. True 2. False 3. True 4. False 5. True

Session 2—Performing Post Installation Tasks in Linux Operating System**Check Your Progress****A. Multiple Choice Questions**

1. (a) 2. (c) 3. (b) 4. (c) 5. (d)

B. Fill in the Blanks

1. Welcome 2. apt install 3. useradd 4. systemd-resolve --status 5. sudo apt update

C. True or False

1. False 2. True 3. False 4. False 5. True

Session 3— Installing and Configuring Peripheral Devices**Check Your Progress****A. Multiple Choice Questions**

1. (c) 2. (b) 3. (c) 4. (a) 5. (c)

B. Fill in the Blanks

1. Keyboard 2. Scanner 3. Printer 4. Speakers 5. Display

C. True or False

1. False 2. True 3. False 4. False 5. True