

Drone Service Technician

(Job Role)

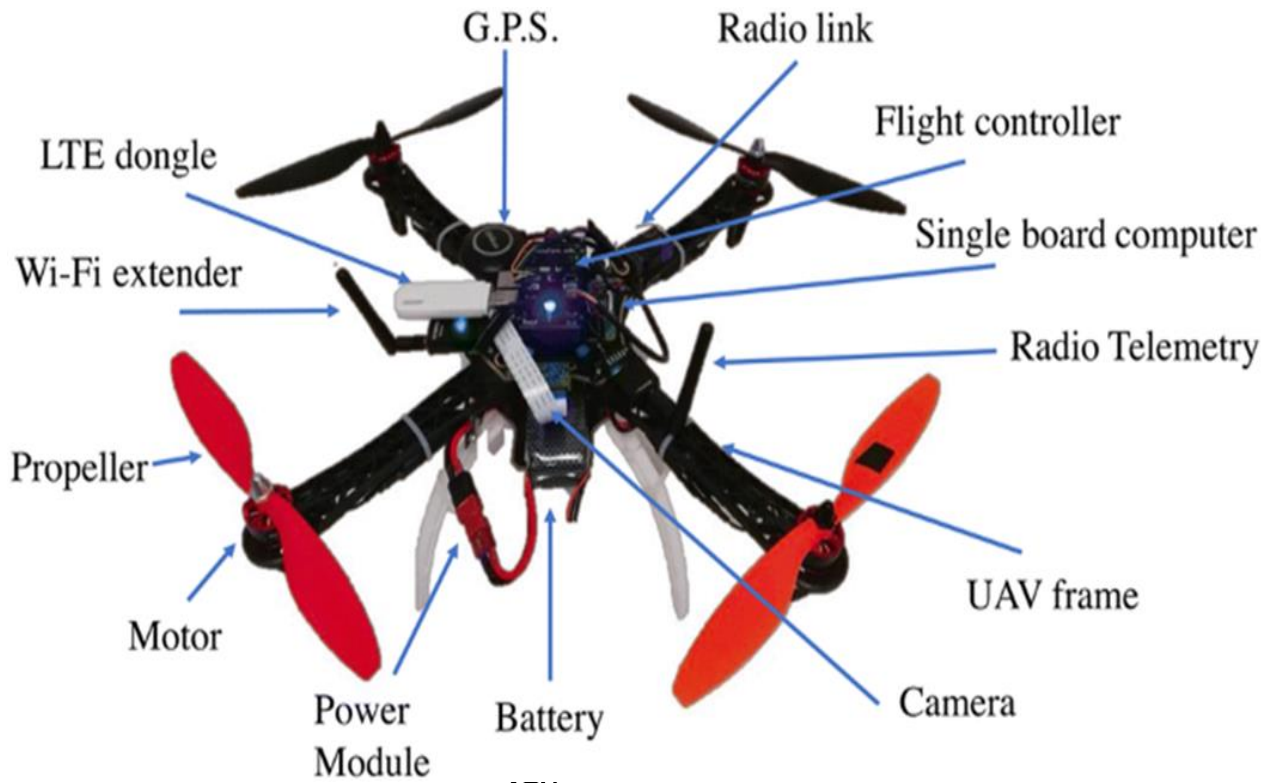

Qualification Pack: Ref. Id. ELE/Q7003

Sector: Electronics Sector Skills Council of India (ESSCI)

Student Textbook for Grade XI



**PSS CENTRAL INSTITUTE OF VOCATIONAL
EDUCATION, SHYAMLA HILLS, BHOPAL, M.P., INDIA**

© PSS Central Institute of Vocational Education, Bhopal 2024

No part of this publication may be reproduced, stored in a retrieval system or transmitted, in any form or by any means, electronic, mechanical, photocopying, recording or otherwise without the prior permission of the publisher.

PSSCIVE Draft Study Material © Not to be Published

Preface

Vocational Education is a dynamic and evolving field, and ensuring that every student has access to quality learning materials is of paramount importance. The journey of the PSS Central Institute of Vocational Education (PSSCIVE) toward producing comprehensive and inclusive study material is rigorous and time-consuming, requiring thorough research, expert consultation, and publication by the National Council of Educational Research and Training (NCERT). However, the absence of finalized study material should not impede the educational progress of our students. In response to this necessity, we present the draft study material, a provisional yet comprehensive guide, designed to bridge the gap between teaching and learning, until the official version of the study material is made available by the NCERT. The draft study material provides a structured and accessible set of materials for teachers and students to utilize in the interim period. The content is aligned with the prescribed curriculum to ensure that students remain on track with their learning objectives.

The contents of the modules are curated to provide continuity in education and maintain the momentum of teaching-learning in vocational education. It encompasses essential concepts and skills aligned with the curriculum and educational standards. We extend our gratitude to the academicians, vocational educators, subject matter experts, industry experts, academic consultants, and all other people who contributed their expertise and insights to the creation of the draft study material.

Teachers are encouraged to use the draft modules of the study material as a guide and supplement their teaching with additional resources and activities that cater to their students' unique learning styles and needs. Collaboration and feedback are vital; therefore, we welcome suggestions for improvement, especially by the teachers, in improving upon the content of the study material.

This material is copyrighted and should not be printed without the permission of the NCERT/PSSCIVE.

Deepak Paliwal

(Joint Director)

PSSCIVE,

Date: 12 March 2025
Bhopal

STUDY MATERIAL DEVELOPMENT COMMITTEE

Members

1. Er. Kuber Singh Consultant, AISECT Bhopal- 462047
2. Er. Parag Shrivastava, Consultant, AISECT Bhopal- 462047
3. Er. Rohit Sapkal, Assistant Manager, AISECT Bhopal- 462047
4. Er. Pankaj Namdev, HOD, Indian Institute of Drone Technology, Dodi, - 466221
5. Er. Yashraj Sunhare Founder & CEO, Jarvis Labs Private Ltd, Bhopal- 462022
6. Er. Manoj Darwai, Assistant Professor, Contractual, Department of Engineering and Technology, PSS Central Institute of Vocational Education, Shyamla Hills, Bhopal, M.P.

Member Coordinator

Saurabh Prakash, *Professor and Head*, Department of Engineering and Technology, Pandit Sunderlal Sharma Central Institute of Vocational Education, Bhopal, Shyamla Hills, Madhya Pradesh, India

Table of Contents

TITLE	PAGE No.
MODULE 01: INTRODUCTION OF DRONES	
Session 1: Introduction of Drones and the role of a Drone Service Technician	
Session 2: Drone Technology and Its Classification	
Session 3: Basic Principles of Electricity, Electronic Components, Hardware and Software of Drone	
MODULE 02: TOOLS FOR DRONE TECHNICIAN	
Session 1: Mechanical Tools	
Session 2: Electrical Tools	
Session 3: Safety Tools	
Session 4: Electrical Parameters	
MODULE 03: MAJOR COMPONENTS OF DRONE	
Session 1: Major components of the drone	
Session 2: Electric and electronic components of the drone	
Session 3: Take off and landings of drone	
MODULE 04: WORK AND SAFETY	
Session 1: Tools Box Talk and Different Types of Hazards	
Session 2: PPE Kit Safety Tools and Safety	
Session 3: Waste Management Concepts	
Answer Key	
Abbreviation	
Glossary	
References	

MODULE 1	INTRODUCTION OF DRONES
Module Overview	
<p>This module provides a comprehensive introduction to drones, also known as Unmanned Aerial Vehicles (UAVs). It covers the fundamentals of drone technology, its historical evolution, types, applications, and the role of a Drone Service Technician in the growing drone industry.</p>	
Learning Outcomes	
<p>After completing this module, you will be able to:</p> <ul style="list-style-type: none"> • Understand the fundamentals, components, and operation of drones (UAVs). • Learn about the history, evolution, and key milestones in drone technology. • Identify different types of drones and their applications across various industries. • Recognize the role, responsibilities, and essential skills of a Drone Service Technician. 	
Module Structure	
Session 1: Introduction of Drones and the role of a Drone Service Technician	
Session 2: Drone Technology and Its Classification	
Session 3: Basic Principles of Electricity, Electronic Components, Hardware and Software of Drone	

Drones, also known as Unmanned Aerial Vehicles (UAVs), are aircraft that operate without a human pilot on-board. They are controlled remotely by an operator or autonomously through pre-programmed flight paths and onboard sensors. Originally developed for military applications, drones have now found widespread use in various sectors, including agriculture, surveillance, disaster management, logistics, and entertainment. Their ability to access hard-to-reach areas, capture high-resolution imagery, and perform tasks efficiently makes them a valuable tool across multiple industries. With advancements in technology, modern drones are equipped with sophisticated navigation systems, GPS, artificial intelligence, and automation features, enhancing their versatility and usability.

The basic components of a drone include a frame, propellers, motors, a flight controller, a power source (usually lithium-polymer batteries), and sensors such as gyroscopes and accelerometers. Drones come in different types and sizes, ranging from small consumer quadcopters to large industrial-grade UAVs. They can be categorized based on their structure, such as fixed-wing, rotary-wing, and hybrid drones. The applications of drones continue to expand with the integration of AI and IoT, enabling them to perform tasks like real-time data analysis, precision agriculture, and autonomous delivery services. As drone technology continues to evolve, regulatory frameworks are being developed to ensure their safe and responsible usage in airspace.



Drone an Unmanned Aerial Vehicles

SESSION 1: INTRODUCTION OF DRONES AND THE ROLE OF A DRONE SERVICE TECHNICIAN

Unmanned Aerial Vehicles

A drone is a flying robot. "Drone" is known as "unmanned aerial vehicles" (UAVs). Drones is being remotely controlled by using onboard sensors and GPS. This drone is an aircraft without any human pilot, crew, or passengers on board.

Drone was being used by Military and intelligence agencies to collect important information. Nowadays, Drones are being used for various areas

such as search and rescue, surveillance, traffic monitoring, videography, weather monitoring, firefighting, spray of agricultural pesticides, delivery of food items and personal tasks. In today's world, drones play an important part in all sectors as they are also being used in the film industry, and news reporters are also using them to carry information from remote locations.

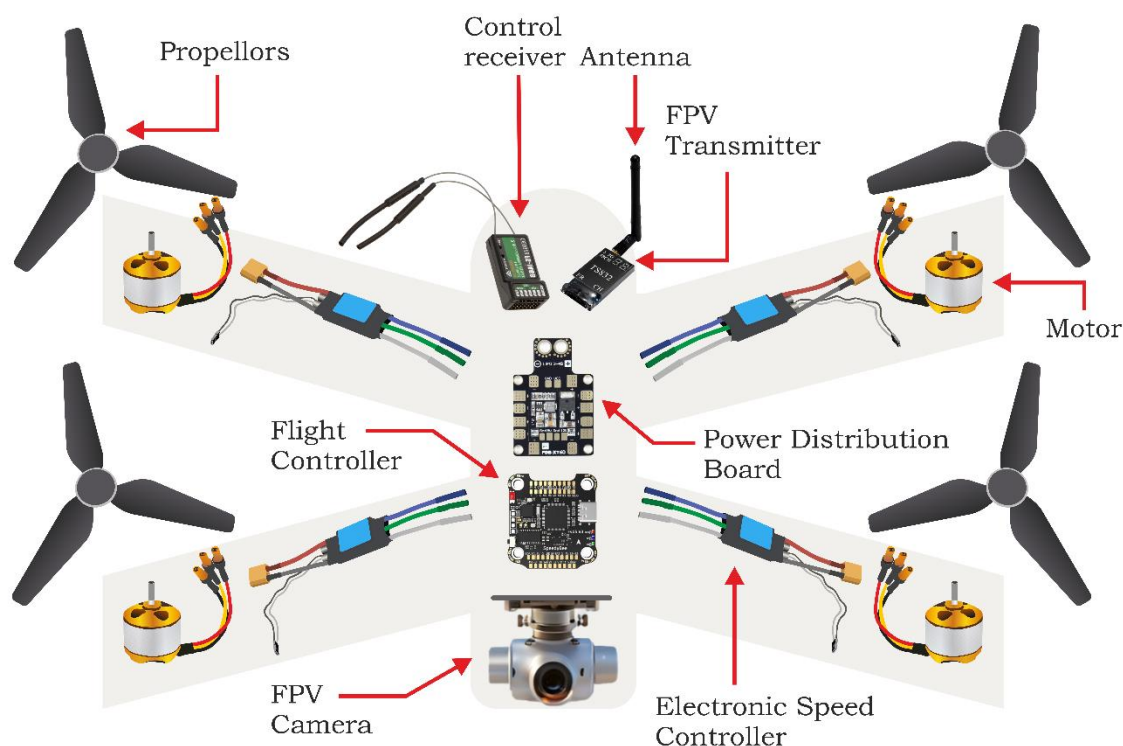

Fig. 1.1 Drone

History and Evolution of Drone

The first pilotless vehicles were developed in Britain and the USA during the First World War. Britain's Aerial Target, a small radio-controlled aircraft, was first tested in March 1917, while the American aerial torpedo known as the Kettering Bug first flew in October 1918. Although both showed promise in flight tests, neither was used operationally during the war.

During the interwar period, the development and testing of unmanned aircraft continued. In 1935, the British produced a number of radio-controlled aircraft to be used as targets for training purposes. It's thought the term 'drone' started to be used at this time, inspired by the name of one

of these models, the DH.82B Queen Bee. Radio-controlled drones were also manufactured in the United States and used for target practice and training.

During the interwar period, the development and testing of unmanned aircraft continued. In 1935, the British produced a number of radio-controlled aircraft to be used as targets for training purposes. It's thought the term 'drone' started to be used at this time, inspired by the name of one of these models, the DH.82B Queen Bee. Radio-controlled drones were also manufactured in the United States and used for target practice and training.

The Indian Army was the first to acquire unmanned aerial vehicles or UAVs in the late 1990s from Israel, and the Indian Air Force and Navy also adopted.

India used military drones during the 1999 Kargil war with Pakistan for the first time. Indian Air Force deployed manned English Canberra PR57 aircraft for photo reconnaissance along the Line of Control, but this system proved highly inefficient and strategically weak over the mountainous Kargil terrain.

After India lost a Canberra PR57 to Pakistani infrared-homing missiles, Israel supplied the Indian Air Force with the IAI Heron and Searcher drones, which were useful for acquiring target information along the Line of Control.

After the Kargil war, India procured numerous Israeli military unmanned aircraft. In 2009, the Indian Air Force purchased 10 Harops in a \$100 million contract with Israel Aerospace Industries. In 2013, the Indian Air Force made a \$280 million deal with Israel Aerospace Industries for a new series of Heron medium-altitude, long-endurance drones.

In June of 2013, India began deploying Heron surveillance drones in a limited capacity over Maoist rebel strongholds in the east. Such activity has been limited to Andhra Pradesh-Odisha and Andhra Pradesh-Chhattisgarh. These states are densely forested, so the UAVs have been of little use in reconnaissance and surveillance.

Back in the 1990s, the Indian Army bought Israeli drones for recce and surveillance, but in 2019, India procured 54 Harop attack drones from Israel. The Air Force already had an inventory of around 110 of these drones.

These drones are equipped with electro-optical sensors to loiter over military targets, such as surveillance bases and radar stations, before exploding them. They have been designed to have a minimal radar signature, allowing them to perform stealth operations. Meanwhile, the state-run Defence Research and Development Organisation (DRDO) and a clutch of private Indian companies are making drones and developing UAV technologies. DRDO has developed its own domestic UAV/UAS program. The project aims to develop a domestic collection of drones to replace and augment the existing fleet of unmanned vehicles. Various defence drones by various names are given below:

DRDO Lakshya

This is a target drone used for discreet aerial reconnaissance and target acquisition. It is launched by a solid propellant rocket motor and sustained by a turbojet engine in flight.

DRDO Nishant

It has been primarily designed for intelligence-gathering over enemy territory. It is also used for reconnaissance, training, surveillance, target designation, artillery fire correction, and damage assessment.

DRDO Aura

Similar to the Lockheed Martin RQ-170 Sentinel, this is a stealth drone capable of releasing missiles, bombs, and precision-guided munitions.

DRDO Rustom

Modelled after the American Predator UAV, the Rustom is a Medium-Altitude Long-Endurance (MALE) system. Like the Predator, the Rustom is designed to be used for both reconnaissance and combat missions. It is expected to replace and supplement the Israeli Heron model UAVs in the Indian Air Force.

These drones can travel at 200 kilometres per hour (km/hr) and fly at altitudes of 6,000-10,000 feet. A higher version of MALE can fly up to an

altitude of 30,000 feet and travel over 200 km/hr. HALE or High-Altitude Long Endurance drone can go beyond 30,000 feet. In India, the use of all aerial vehicles, manned or unmanned, is governed by the Directorate General of Civil Aviation (DGCA), and foreigners are currently not allowed to fly drones in India.

Notably, in 2018, Harshvardhan, an Indian teen, invented a drone to detect and defuse landmines. He watched a YouTube video where soldiers were trying to defuse a mine, and the mine exploded suddenly, injuring several of them. He, thus, designed a drone that could detect the mines without seeing them off and then drop a marker to allow mine clearers to detonate them safely.

There are more than 100 million active landmines across the globe and such drones would be useful to save thousands of lives across the world.

<https://shorturl.at/ewzVW>

Role and Responsibilities of Drone Service Technician

A Drone Service Technician is an important Job role in the electronics sector. Drone service technician will repair, maintain and test various types of drones such as UAVs (unmanned aerial vehicles) or UASs (Unmanned Aircraft Systems) etc. The Drone Service Technician is responsible for the assembling or disassembling of the drone and will gather materials required for installation and maintenance of the drone. The person should be able to work independently on the assignment, be comfortable in performing laborious work, be a good listener, good at following instructions, be a cooperative team player, and be result-oriented, with a positive attitude.

The important technical responsibilities of a Drone Service Technician are given below:

- Understanding the drone-related issues faced by the customer
- Ensure proper handling of various tools and other materials.
- Assess precautionary measures to be taken.
- Ensure effective functioning of the system post-repair and maintenance.
- Manage waste and workplace safety.

- Deliver quality work as per standards despite constraints.
- Ensure customer satisfaction and get feedback on standards of work
- Working in a disciplined and ethical manner.
- Dealing with workplace hazards.
- Informing the supervisor of the work load and completion status.
- Installing repaired / fresh electronic components using appropriate tools and equipment

CHECK YOUR PROGRESS

A. Fill in the Blanks

1. The main responsibility of a Drone Service Technician is _____ (**drone maintenance and repair**)
2. DRDO Nishant was primarily designed for _____ (**intelligence-gathering**)
3. The application of drones in the agriculture sector is done for _____ application. (**fertilizer/ pesticide spray**)
4. UAVs stand for _____ (**unmanned aerial vehicles**)
5. The full form of DRDO _____ (**Defence Research and Development Organisation**)

B. Multiple Choice Questions

1. What is the main responsibility of a Drone Service Technician?
 - a) Drone piloting and aerial photography
 - b) **Drone maintenance and repair**
 - c) Drone software development
 - d) Drone market analysis
2. Which of the following tasks does a Drone Service Technician NOT perform?

- a) Conducting safety inspections before drone flights
 - b) Installing and calibrating drone cameras
 - c) **Developing drone hardware components**
 - d) Troubleshooting and diagnosing drone issues
3. What skills are essential for a Drone Service Technician?
- a) **Computer programming and coding**
 - b) Customer service and communication
 - c) Graphic design and animation
 - d) Interior design and decoration
4. What does a Drone Service Technician do during routine maintenance?
- a) Flying the drone for recreation
 - b) **Cleaning and inspecting the drone's components**
 - c) Creating marketing materials for drone services
 - d) Offering training sessions for drone pilots
5. Which of the following is a part of a Drone Service Technician's role regarding data management?
- a) Editing drone footage for documentaries
 - b) **Collecting and analysing data from drone flights**
 - c) Creating social media content for a drone company
 - d) Designing 3D models for architectural projects

C. Short Answer Questions

1. Explain the primary duties of a Drone Service Technician.
2. List the five applications of drones in our country.
3. Write the five-drone name developed by DRDO.
4. List five drones developed by international agencies.

5. Define the specifications of DRDO Rustom.

SESSION 2: DRONE TECHNOLOGY AND ITS CLASSIFICATION

Drone Technology

Drone technology refers to the design, development, and use of drones/unmanned aerial vehicles (UAVs). Drones are essentially flying robots that can be remotely controlled or programmed to fly autonomously. They have become increasingly popular and are used in various industries and applications.

Drones rely on a combination of hardware and software components to achieve successful take-off, flight and landing. Drones are often equipped with rotors or fixed wings, sensors, navigation systems and gyroscopes (for stability) and are operated by ground control stations.

There is various drone technologies used for various purposes. We will discuss the Importance of drone technology and its application.

1) Vertical Take-Off and Landing Drone (VTOL)

Many drones are not capable of vertical take-off and landing. VTOL Drones are quadcopters that can take off, fly, hover, and land vertically. That is why it is called VTOL.

2) Radar positioning drone technology

These drones are equipped with dual navigation technology. It connects to a group of navigation satellites when it is turned on. This satellite constellation gives this drone accurate coordinates of the destination.

3) Obstacle Detection drone technology

This kind of drone is loaded with many detection sensors, such as ultrasonic, vision sensor, infrared, lidar, monocular vision etc. These drones scan surroundings and do the 3D mapping

4) Gyro Stabilization drone technology

Drones are equipped with a gyroscope technique which allows them to fly, rover, and land smoothly against any external force.

5) Drone propulsion technology

These drones have a propulsion system that allows them to fly and hover in any direction.

6) GPS drone technology

This type of drone has a GPS, which helps in knowing the real-time location and improves accuracy.

7) Drone Transmission technology

Such drones are used to send and receive real-time data. With the introduction of the 5G network, the accuracy and speed of transmission of data in such drones have improved manifold.

8) Live video drone technology

These drones are equipped with high-definition cameras that record and transmit real-time video (Live Video) of a location while flying at a certain height.



Fig. 1.2 Drone Parts

Classification of Drone

Drones can be categorized by their size, weight, range, speed, endurance, production cost, propulsion, etc. Drones are classified into different categories based on their applications. Applications are broad and from the design perspective, generally fall under three major groups: military, industrial (enterprise) and commercial.

Military: Drones play a crucial role in modern military operations, offering enhanced surveillance, reconnaissance, and tactical capabilities. Equipped with advanced imaging systems, AI-powered navigation, and precision-strike

capabilities, military drones enable real-time intelligence gathering and strategic decision-making. They are used for border security, battlefield monitoring, target acquisition, and even combat missions, reducing the risk to human soldiers. Additionally, unmanned aerial vehicles (UAVs) are deployed for logistics, carrying supplies to remote or high-risk areas. The integration of cutting-edge technologies, such as stealth, swarm intelligence, and autonomous systems, continues to revolutionize drone applications in defence.

Industrial (Enterprise): Drones are transforming industrial and enterprise operations by enhancing efficiency, safety, and cost-effectiveness across various sectors. In industries like construction, drones provide aerial mapping, site inspections, and structural monitoring, reducing the need for manual labour in hazardous environments. In agriculture, they assist with precision farming by monitoring crop health, optimizing irrigation, and spraying pesticides. Logistics and warehousing companies utilize drones for inventory management and last-mile delivery. Additionally, drones are increasingly used in energy sectors for inspecting power lines, wind turbines, and oil rigs. With advancements in AI and automation, drones are becoming integral to industrial innovation, streamlining operations, and improving productivity.

Commercial: The classification of drones follows the same standard with some essential changes to the Nano category. In the previous UAS Rules, drones were categorized based on their method of operation and then further classified based on their size and speed. However, under the latest drone regulations, drones in India are classified into:

1. **Nano drone:** Less than or equal to 250 grams.
2. **Micro drone:** Greater than 250 grams and less than or equal to 2 kilograms.
3. **Small drone:** Greater than 2 kilograms and less than or equal to 25 kilograms.
4. **Medium drone:** Greater than 25 kilograms and less than or equal to 150 kilograms.

5. **Large drone:** Greater than 150 kilograms.

The removal of speed (15 m/s) and altitude (15m) restrictions from nano drones will provide greater flexibility of operation, such as first-person view (FPV) and hobby drones.

Here, drones can be of four types depending on their rotor or wing.

1. Multi-rotor drones
2. Fixed-wing drones
3. Single-wing Helicopters
4. Fixed-wing Hybrid VTOL (vertical take-off and landing)

Applications of Drone

Today, the application areas of drones are limitless. The technology that was once designed to destroy is now being used for the betterment of mankind. Drones have become an eye in the sky to give us the top-down majority view. With drones being allowed for commercial use, an entire industry has emerged. That’s why most developed and developing countries are working to integrate drones into their national airspace.

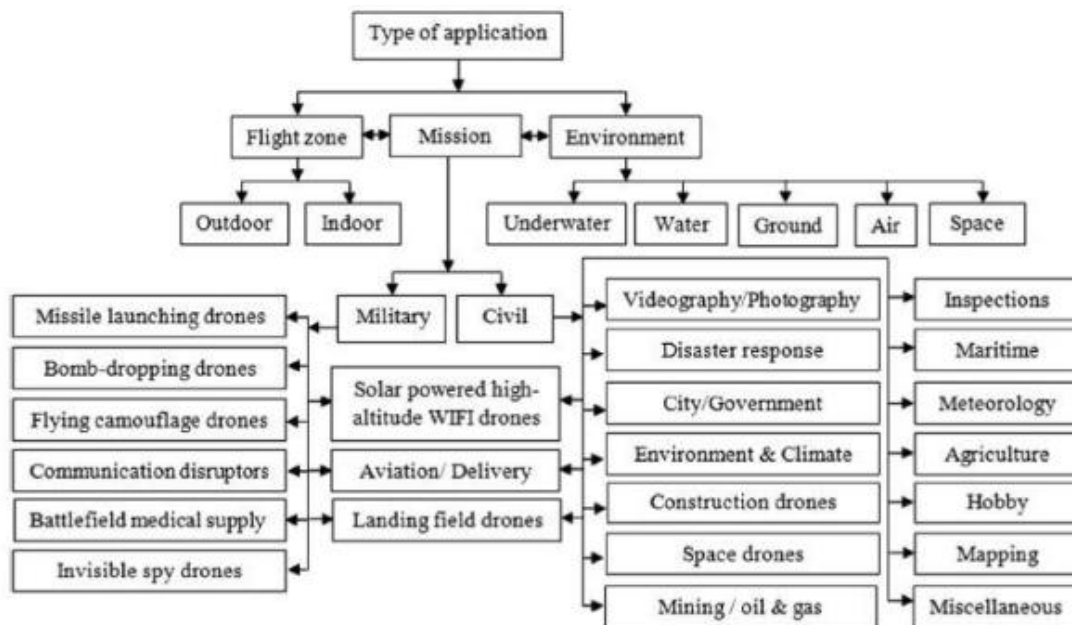

List of Applications of Drones

Photography and Cinematography: Drone photography allows images and audio/video to be captured that might not be otherwise possible for human

photographers and videographers. That capacity can be enabled by the flight abilities of drones, their small size or their ability to tolerate harsh environments. Drone photography often enables a first-person view (FPV) that would normally be impossible to achieve.

Surveying: Drone Survey Equipment and Software for Professional Applications including surveying, mapping, construction, engineering, land development, inspection, etc. Drone technology represents a huge potential for surveyors and Geographic Information System (GIS) professionals. It greatly cuts the cost and work hours of data capture. Further, you can survey otherwise unreachable areas and deliver high-resolution aerial maps that would be otherwise impossible to produce in a safe or cost-effective way.

Real Estate/construction and infrastructure: Drones have revolutionized the real estate, construction, and infrastructure industries by enhancing efficiency, accuracy, and safety. In real estate, drones provide high-resolution aerial imagery and videos, enabling realtors to showcase properties with immersive virtual tours and detailed topographical views. This enhances marketing strategies and attracts potential buyers. In construction, drones are used for site surveys, progress monitoring, and 3D mapping, reducing the time and cost of manual inspections. They improve safety by allowing remote assessments of hazardous areas, ensuring compliance with regulations. In infrastructure projects, drones facilitate bridge and road inspections, railway monitoring, and urban planning by capturing real-time data, helping engineers make informed decisions and maintain structural integrity.



Fig. 1.3 Real Estate/construction and infrastructure

Drones for Mining: The top companies in the world have already started to integrate drones for mining. Drones have proven to be vital tools across every part and phase of a mine site—from exploration to drilling and blasting to reclamation. So, they are here to stay. Today, the question about drones is no longer if they work, but rather which drone mining platforms are best for getting the most benefits. It's possible to save a lot of time and money with the right mining drone for mining applications that would otherwise present huge challenges with a sub-par system.



Fig. 1.4 Application in Mining

Remote Sensing: Remote sensing is a technique that uses specific instruments to capture information from a remote distance. Clearly, when a UAV is equipped with sensors with remote sensing capabilities, it has the flexibility to gather information against exclusive targets while under remote human control.

Agricultural: Agriculture is yet another important application of the technology, where drones are offering farmers affordable and effective methods to monitor crops. Drones equipped with infrared sensors are especially helpful in monitoring crop health, giving farmers faster and more reliable information to take precautionary measures to improve crop conditions and yield. According to estimates, drone technology will cover 80% of the agriculture industry in the coming few years.

Photography

Search and Rescue: The thermal sensors onboard enable drones to become potent tools for night-time surveillance. Drones can be used to track lost persons across forests, mountains, and rugged terrains, and they can be

equipped with infrared and thermal sensors for equal effectivity day and night. Many modern drones are capable of operating in harsh conditions as well, making them effective search and rescue tools. Apart from their role in search of lost persons, drones can also be used to airdrop essential supplies to disaster-struck or war-torn areas. For instance, drones can be loaded with GPS locators, food supplies, medicines, and other essential supplies to help people survive until the help arrives.

Military: The military was the first user of drone technology, which was used to gather crucial enemy information from the battleground. Technology today has only boosted its efficiency in terms of gathering crucial information not just from the battlefield but during peaceful times as well. Today, powerful drones flying thousands of miles above the sky and equipped with the most powerful imaging tools can gather complete information about the enemy's military presence inside its territory. Small quadcopters are also routinely used for border surveillance to get real-time information about the forward posts of enemies.

Disaster Management: Drones provide quick means, after a natural or man-made disaster, to gather information and navigate debris and rubble to look for injured victims. Its high-definition cameras, sensors, and radars give rescue teams access to a higher field of view, saving the need to spend resources on manned helicopters. Where larger aerial vehicles would prove perilous or inefficient, drones, thanks to their small size, are able to provide a close-up view of areas.

Entertainment: Drones are being developed to provide entertainment for players so that they can be used in fight clubs. Known as a cage match, two contenders and their drones are put up against each other. The destruction of any of the player's drones results in the other's win. Moreover, artificial drone intelligence is used in several ways to capture videos and photographs, for example, the Dronie, which is used to take selfies. As technology advances, drones will become more robust and advanced,

accommodating longer flight times and heavier loads. The industry comes with immense opportunities for businesses, gradually becoming inevitable for them. It is, therefore, important for organizations to study the scope of drone technology in their area of business, build the required infrastructure, and test their services across it.

Law enforcement: Law enforcement agencies widely use drones to maintain law and order situations. The applicability of drones becomes even more crucial during protests, where the technology enables law enforcement agencies to closely and consistently monitor the situation of protest and spot any unlawful event before it spirals out of control. Apart from its application in maintaining law and order in cities, drones are also used by border management agencies to track smugglers and illegal transportation of drugs through remote, inaccessible areas or coastlines.

Wildlife monitoring: Drones have been used for quite some time as a deterrent to poachers. The unique ability of drones to keep surveillance over large areas consistently across all weather makes them ideal technology to monitor wildlife in deep forests or massive grasslands. Apart from acting as a deterrent against poachers, drones are also used by scientists to track endangered animals, as well as study their behaviour and habitat.

Forestry: Drones are used to map natural and man-made forests, providing accurate and timely data for analysing tree health, tree counting, biomass estimation, canopy measurement and planting management.

Port and Marine: Drones are used in ports and marine for surveying hard-to-reach places and assessing a vessel's condition. Aerial surveying removes the logistics and time investments and delivers on-demand insights in port monitoring, traffic control, operational oversight and environmental health and safety.

Another Drone application in a different sector

- ☞ Aerial Photography and Videography
- ☞ Real estate photography
- ☞ Mapping and Surveying
- ☞ Asset Inspection

- ☞ Payload carrying
- ☞ Agriculture
- ☞ Bird Control
- ☞ Crop spraying
- ☞ Crop monitoring
- ☞ Multispectral/thermal/NIR cameras
- ☞ Live streaming events
- ☞ Roof inspections
- ☞ Emergency Response
- ☞ Search and Rescue
- ☞ Marine Rescue
- ☞ Disaster zone mapping
- ☞ Disaster Relief
- ☞ Forensics
- ☞ Mining
- ☞ Firefighting
- ☞ Monitoring Poachers
- ☞ Insurance
- ☞ Aviation
- ☞ Meteorology
- ☞ Product Delivery

Practical Exercise

1. Identify the different types of drones based on weight.
2. Identify different types of drones based on rotor/wing.

CHECK YOUR PROGRESS

A. Fill in the Blanks

1. Drones can be classified based on their size,, and payload capacity. **(shape)**
2. Size-based classification divides drones into categories such as micro, mini, and ____ drones. **(large)**

3. Shape-based classification includes different types, like quadcopters, _____, and fixed-wing drones. **(hexacopters)**
4. Classification based on _____ involves distinguishing drones used for photography and surveillance. **(Photography, Surveillance, Delivery)**

B. Multiple Choice Questions

1. Drone classification involves categorizing UAVs based on attributes like:
 - a) Size, shape, propulsion, capabilities, and usage**
 - b) Colour, altitude, material, and country of origin
 - c) Speed, weight, price, and manufacturer
 - d) Age, model number, range, and operating frequency
2. Drones can be classified into different size categories, such as:
 - a) Nano, micro, mini, and large drones**
 - b) Small, medium, large, and extra-large drones
 - c) Tiny, small, medium, and giant drones
 - d) Mini, standard, large, and jumbo drones
3. Which type of drone has wings similar to those of an airplane and requires a runway for take-off and landing?
 - a) Quadcopter
 - b) Hexacopter
 - c) Octocopter
 - d) Fixed-wing drone**
4. Drone classification based on function involves categorizing drones used for:
 - a) Photography, surveillance, delivery, and military applications**
 - b) Racing, gaming, leisure, and agricultural purposes
 - c) Scientific research, wildlife monitoring, and space exploration

d) Tourism, construction, mining, and disaster relief

C. Short Answer Questions

1. What is drone classification?
2. Name three types of drones based on their shape.
3. What are the primary criteria used for classifying drones?
4. How does the function of a drone impact its classification?
5. What was the name of the first successful military drone introduced in the 1980s?

SESSION 3: BASIC PRINCIPLES OF ELECTRICITY, ELECTRONIC COMPONENTS OF DRONE AND HARDWARE AND SOFTWARE OF DRONE

Basic Principles of Electricity

The basic principles of electricity form the foundation of our understanding of electrical systems and how electricity behaves. Electricity is the flow of electric charge, primarily carried by electrons in a conductor. Key concepts such as voltage, current, and resistance govern the behavior of electrical circuits and are defined by Ohm's Law, which states that voltage (V) equals current (I) multiplied by resistance (R). Additionally, electrical energy can be stored and released using components like capacitors and inductors, while conductors and insulators determine how efficiently electricity flows. Understanding these principles is crucial for designing, troubleshooting, and optimizing electrical systems in various applications, from household wiring to advanced electronic devices.

Electric Charge: Electric charge is a fundamental property of matter. Atoms are composed of protons (positively charged), electrons (negatively charged), and neutrons (neutral). When an atom gains or loses electrons, it becomes positively or negatively charged, respectively.

Voltage (Electric Potential Difference): Voltage, measured in volts (V), is the difference in electric potential energy between two points in an electrical circuit. It is the driving force that pushes electric charges through the circuit.

Resistance: Resistance, measured in ohms (Ω), is a property of a material that opposes the flow of electric current. Materials with high resistance impede the flow of current, while those with low resistance allow current to flow more easily.

Ohm's Law: Ohm's Law relates the voltage, current, and resistance in an electrical circuit. It states that the current (I) flowing through a conductor is

directly proportional to the voltage (V) applied across it and inversely proportional to the resistance (R) of the conductor ($I = V/R$).

Series and Parallel Circuits: Components in an electrical circuit can be connected in series or parallel. In a series circuit, components are connected in a single path, and the current is the same in all components. In a parallel circuit, components are connected in multiple paths, and the voltage is the same across all components.

Power: Power, measured in watts (W), is the rate at which electrical energy is used or transferred in an electrical circuit. It is calculated as the product of voltage and current ($P = V \times I$) or as the square of current multiplied by resistance ($P = I^2R$).

Electromagnetism: When an electric current flows through a conductor, it creates a magnetic field around the conductor. This relationship between electricity and magnetism is the basis for electromagnets and the functioning of electric motors and generators.

DC and AC Electricity: Direct Current (DC) flows in one direction, maintaining a constant polarity. Batteries and most electronic devices use DC power. Alternating Current (AC) periodically changes direction and is commonly used in household electrical outlets and power distribution grids.

Electric Current: The flow of electricity in an electronic circuit, as well as the amount of electricity flowing through it, is referred to as electric current. It is measured in amperes (A). The higher the ampere value, the more electricity flows across the circuit. Imagining electricity as the flow of water in a river makes it simple to understand. Particles called electrons come together, and the number of electrons flowing each second is the current.

Voltage: is a word that is used in electrical circuits almost as frequently as current. Volts are the unit of measurement for voltage (V). Voltage is

connected to the passage of electrons in a circuit, just like the current. The flow of electrons is referred to as current, and the amount of force driving the electrons is referred to as voltage.

The two types of electric current flow are:

Direct Current: The one-direction flow of an electric charge is known as direct current. Direct current can flow via conductors like wires, but it can also flow through semiconductors and even a vacuum.

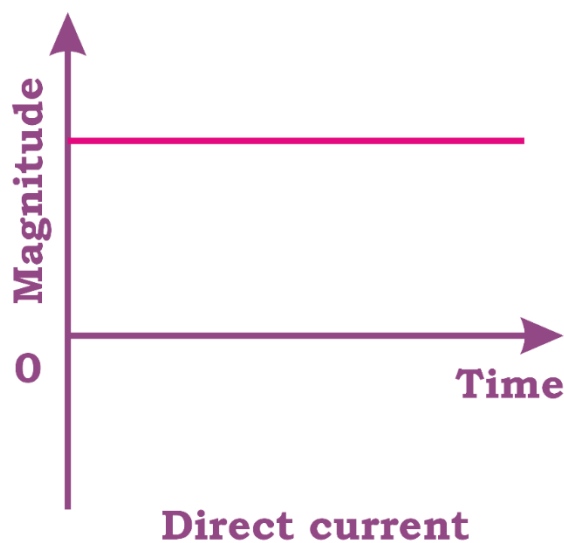

Fig. 1.6 Direct Circuit

Alternating Current: An electrical current that repeatedly changes or reverses its direction is called an alternating current. AC changes its magnitude and polarity at regular intervals of time.

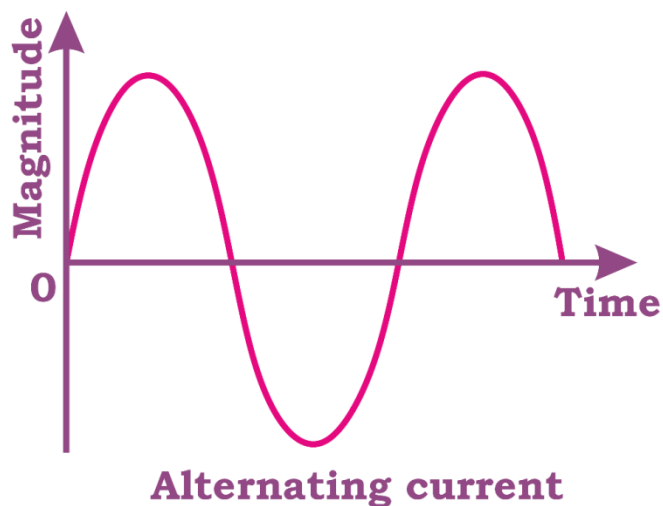

Fig. 1.7 Alternating current

Electric Circuit: A channel through which electric current flows is known as an electric circuit. An electric circuit can also be a loop if it is a closed path (both ends are connected). Because of the closed circuit, electric current may flow freely. An open circuit is one in which the passage of electrons is interrupted because the circuit is broken. An open circuit does not allow an electric current to flow.

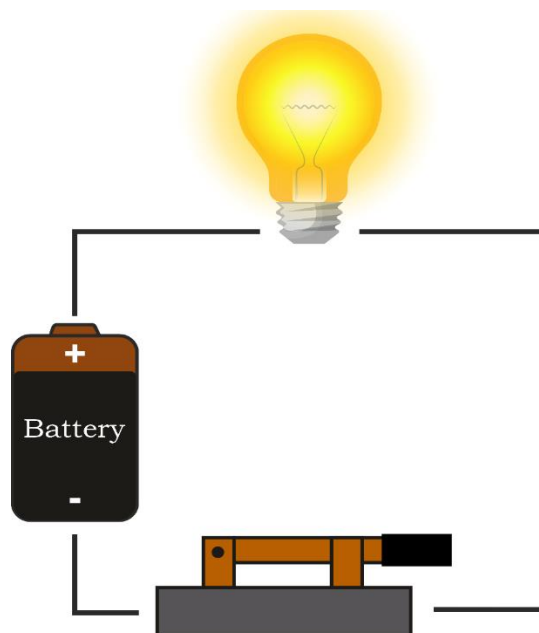

Fig. 1.8 Closed circuit

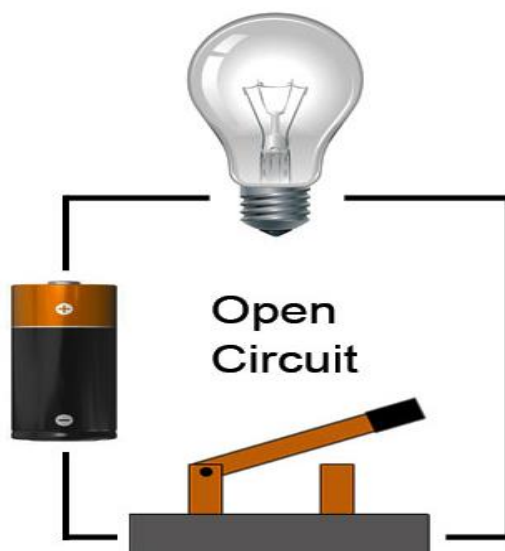

Fig. 1.9 Open Circuit

Parts of an Electric Circuit

The functions of parts of an electric circuit are:

Cell or electric source: It is used as a source to supply electric current.

Load: It is a resistor. It is a light bulb which glows when the circuit is turned on.

Conductors: Copper wires are used as conductors with no insulation. One end of the wire carries current from the power source to the load and the other end from the power source.

Switch: It is a part of the circuit that controls the supply of current in the circuit. It is used to open or close the circuit.

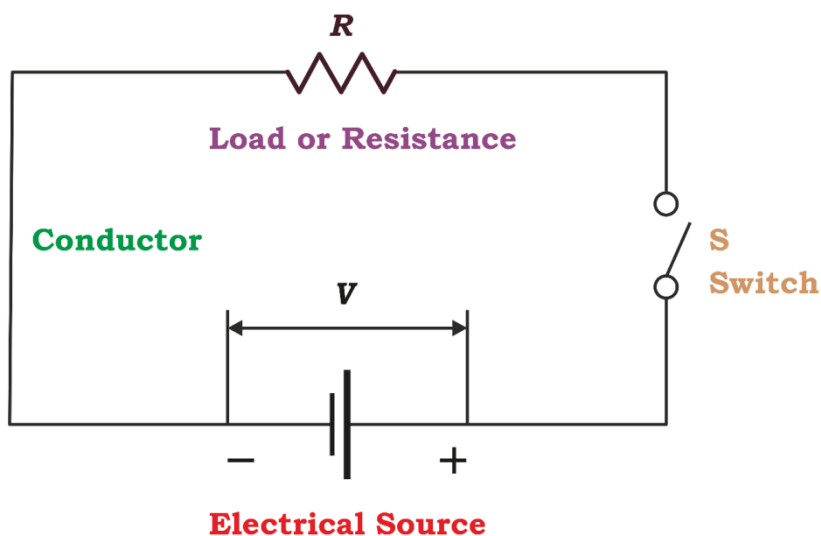

Fig.1.10 Parts of an Electric Circuit

Types of Electric Circuits

There are two types of electric circuits.

- Series Circuit
- Parallel Circuit

Series Circuit

In a series circuit, electrons can only flow in one direction. At the same moment, the circuit is closed or open. The fundamental drawback of a series circuit is that no current flows in the circuit in the event of a circuit break since the whole circuit is open. If any light bulbs are linked in a series circuit, for example, if one goes out, the others will likewise go out.

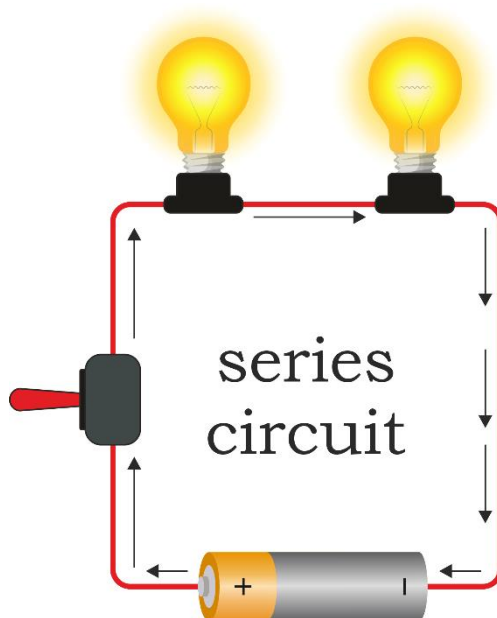

Fig.1.11 Series Circuit

Parallel Circuit

In a parallel type of electric circuit, different parts of the circuit are connected across different branches. Hence, electron flow occurs in several parts. If in one path a circuit break occurs, electric current still flows in other paths. Parallel circuits are used in household appliance wiring, so if one light bulb fails, the other will continue to operate.

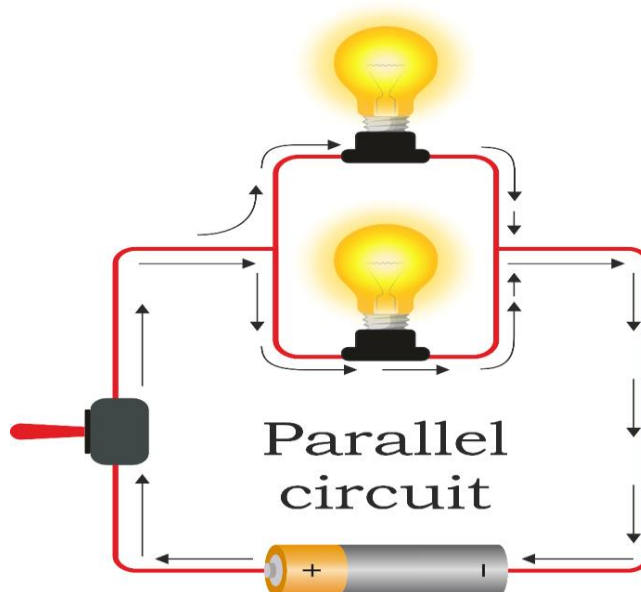

Fig.1.12 Parallel Circuit

Electronic Components of Drone

Electronic components are the elements of the circuit that help in its functioning. They can be classified into two types, i.e. Active Components and Passive Components. Active components include transistors, batteries, etc., while passive components include transformers, inductors, resistors, capacitors, etc. The electronic components and their functions are discussed below:

Resistors: A resistor is one of the components one will come across in an integrated circuit. As the name suggests, the device resists the flow of current. Resistors are graded based on their power ratings (amount of power they can handle without exploding) and resistance values (capacity to resist current). The measurement is done in units known as ohms. The electronic symbol of the unit is Ohm.

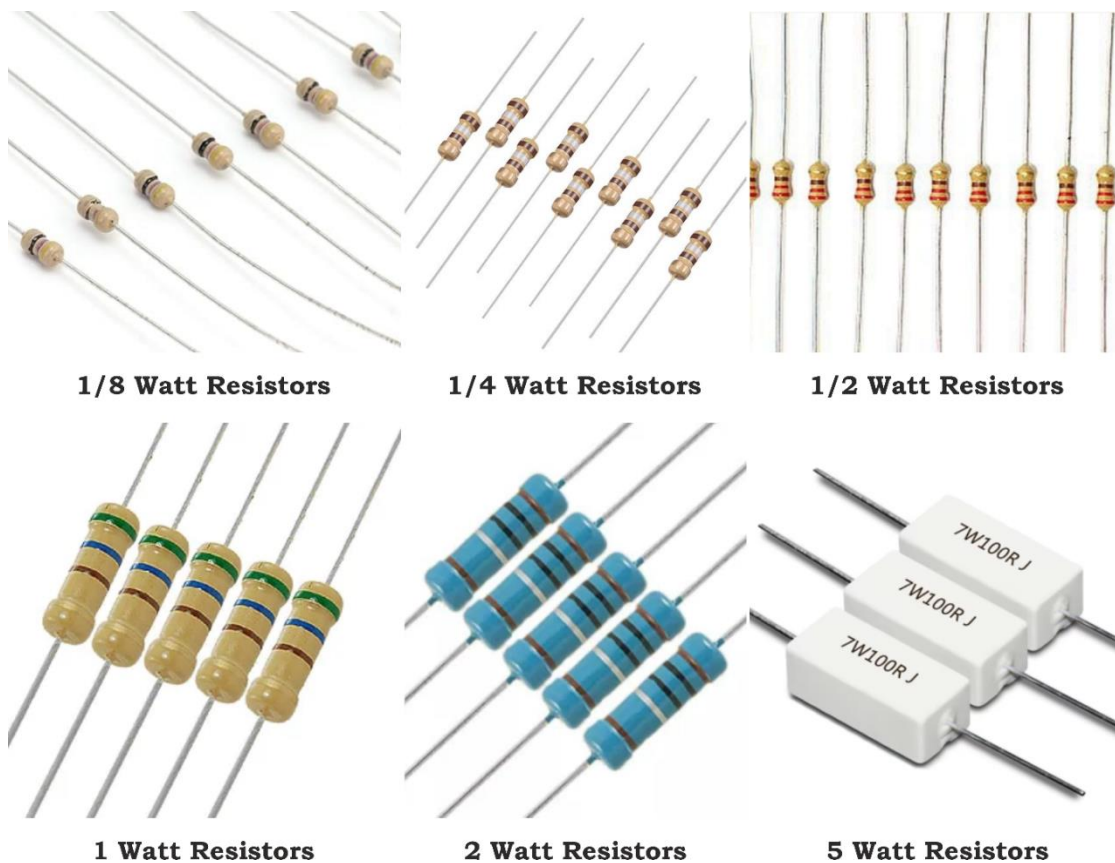

Fig.1.13 Resistors

Capacitors: These components can store an electric charge temporarily. The components come in different varieties, with the most common ones being electrolytic and ceramic disks. The capacity of a component is usually measured in microfarads (μF).



Fig. 1.14 Capacitor

Diodes: Diodes allow an electric current to flow in a single direction only. Each diode has two terminals known as the anode and cathode. When the anode is charged with a positive voltage and the cathode with a negative one, an electric current can flow. Reversing these voltages will prevent the current from flowing.



Fig.1.15 Diode

Transistors: These components are easy to identify through their three terminals. For the components to work, voltage has to be applied to one of them; the base terminal. The base can then control the current flow in the two other terminals (the emitter and collector).

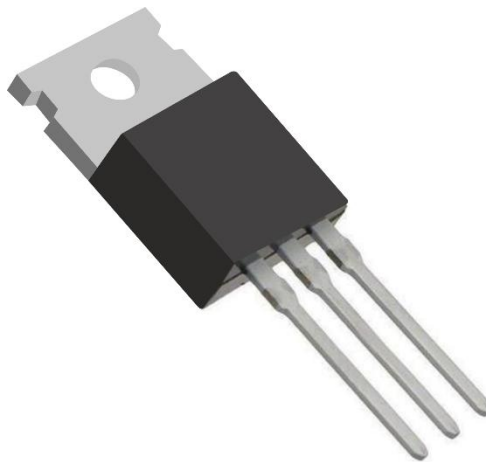

Fig.1.16 Transistors

Inductors: These are passive components that store energy in the form of a magnetic field. An inductor simply consists of a coil of wire wound around some kind of core. The core could be a magnet or air. When the current passes through the inductor, a magnetic field is created around it. The magnetic field is stronger if a magnet is used as the core.



Fig.1.18 Inductors

Integrated Circuits: An integrated circuit refers to a special device that has all the components required in an electronic circuit. The component has diodes, transistors, and other devices, all of which are etched on a tiny piece of silicon. The components are used in many electronic devices, including watches and computers.

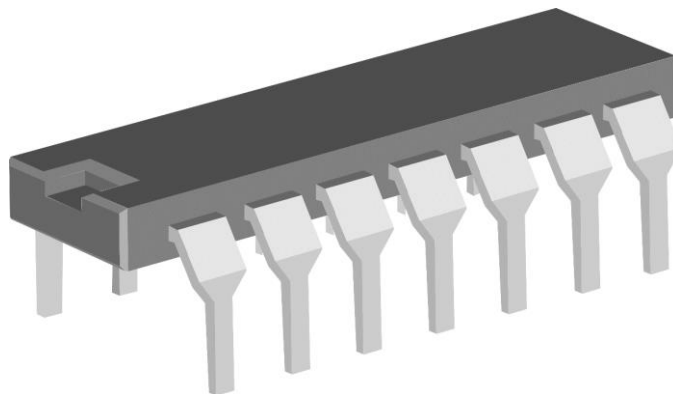

Fig.1.19 Integrated Circuits

Microcontrollers: A microcontroller is a small computer on a single VLSI integrated circuit chip. A microcontroller contains one or more CPUs along with memory and programmable input/output peripherals.

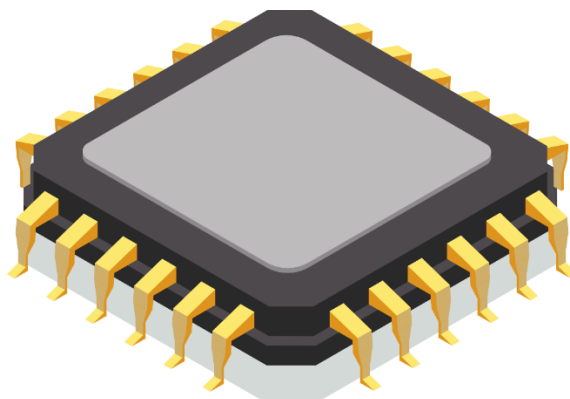

Fig.1.20 Microcontroller

Transformers: It is built with two coils of wire. Transformers are commonly used to step up or step-down power.

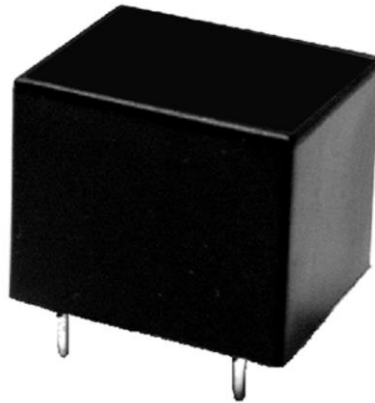

Fig. 1.22 Transformers

The step-up transformer is a type of transformer with the function of converting low voltage (LV) and high current from the transformer's primary side to high voltage (HV) and low current value on the transformer's secondary side.

A step-down transformer is a type of transformer that converts the high voltage (HV) and low current from the primary side of the transformer to the low voltage (LV) and high current value on the secondary side of the transformer. The reverse of this is known as a step-up transformer.

Batteries: Batteries convert chemical energy to electrical energy. The two different cells of a battery are the anode (+) and cathode (-).



Fig.1.21 Batteries

Fuses: Fuses help prevent components from overloading with excessive current. A fuse consists of a connection body, support, contacts, and metal-fuse material, such as zinc or copper.

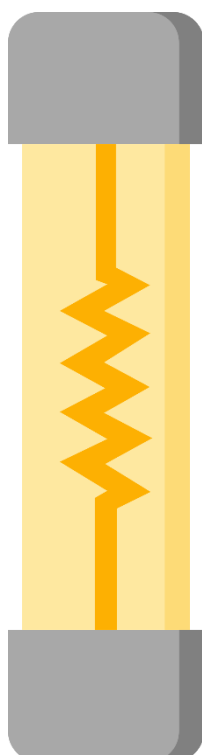

Fig.1.23 fuse

Relays: These electromechanical switches shut power on or off. A relay includes an electromagnet, an armature, a series of electrical contacts and a spring.

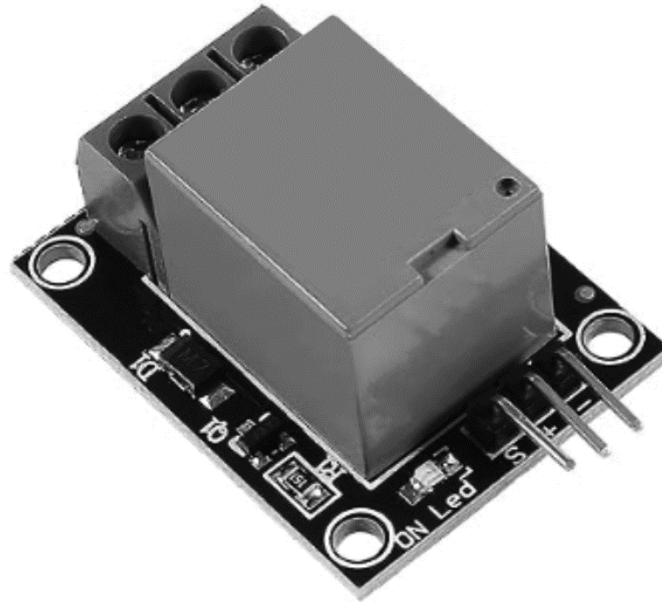

Fig.1.24 Relays

Switches: Switches interrupt current. The four types of switches are single pole single throw (SPST), single pole double throw (SPDT), double pole single throw (DPST), and double pole double throw (DPDT).

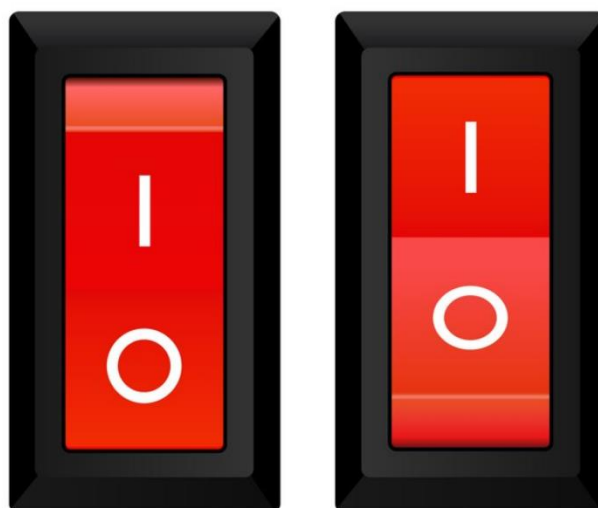

Fig.1.26 Switches

Motors: Motors convert electrical energy into mechanical energy. Key components include a rotor, stator, bearings, conduit box, enclosure, and eye bolt.



Fig.1.25 motors

Practical Exercise

1. Identify the electronic components of the drone.
2. Make a list of the various electronic components of the drone.

CHECK YOUR PROGRESS

A. Fill in the Blanks

1. Electric charge is a fundamental property of matter. It can be positive or _____, and it is carried by protons and electrons. **(Negative)**
2. Electric current is the flow of electric charge through a conductor. It is measured in _____ and is the rate at which charges move past a point in a circuit. **(Amperes (A))**
3. Voltage is the _____ that causes electric charges to move in a circuit. It is measured in volts (V). **(Electric potential difference)**
4. Resistance is the opposition to the flow of electric current in a circuit. It is measured in _____ and depends on the material and dimensions of the conductor. **(Ohms (Ω))**

5. Ohm's Law: Ohm's Law states that the current in a circuit is directly proportional to the voltage and _____ to the resistance. It is expressed as $I = V / R$. **(Inversely)**

B. Multiple Choice Questions

1. Electric charge is a fundamental property of matter that can be:
 - a) Positive only
 - b) Negative only
 - c) Positive or negative**
 - d) Neutral
2. The flow of an electric charge through a conductor is called:
 - a) Electric voltage
 - b) Electric current**
 - c) Electric resistance
 - d) Electric power
3. Voltage is measured in:
 - a) Ohms (Ω)
 - b) Amperes (A)
 - c) Volts (V)**
 - d) Watts (W)
4. Resistance is the opposition to the flow of electric current and is measured in:
 - a) Ohms (Ω)**
 - b) Amperes (A)
 - c) Volts (V)

- d) Watts (W)
5. Ohm's Law relates voltage (V), current (I), and resistance (R) through the equation:
- a) **$V = I \times R$**
 - b) $V = I / R$
 - c) $I = V \times R$
 - d) $I = V / R$
6. In a series circuit, the total resistance is:
- a) **The sum of individual resistances**
 - b) The product of individual resistances
 - c) The average of individual resistances
 - d) Equal to zero
7. In a parallel circuit, the voltage across each branch is:
- a) **The sum of individual voltages**
 - b) The product of individual voltages
 - c) The average of individual voltages
 - d) Equal to zero

C. Short Answer Questions

1. Explain the use of various types of electronic components, hardware and software of drone
2. What is an electric charge, and what particles carry it?
3. Define electric current and state its unit of measurement.
4. What is voltage, and what unit is used to measure it?
5. Explain resistance and its unit of measurement.
6. State Ohm's Law and its mathematical expression.
7. What is the total resistance in a series circuit?

8. What is the voltage across each branch in a parallel circuit?
9. What happens to the total resistance when two equal resistors are connected in a series?
10. What is the primary purpose of a fuse or circuit breaker in an electrical circuit?

MODULE 2	TOOLS FOR DRONE TECHNICIAN
Module Overview	
This module provides an in-depth understanding of the essential tools required for maintaining, repairing, and troubleshooting drones. It covers mechanical, electrical, and safety tools, along with key electrical parameters crucial for drone operations	
Learning Outcomes	
After completing this module, you will be able to: <ul style="list-style-type: none"> • Identify and use mechanical tools such as screwdrivers, pliers, wrenches, and tweezers for assembling and repairing drones. • Understand the functions of electrical tools like multimeters, wire strippers, and circuit testers for diagnosing and fixing drone circuits. • Recognize the importance of safety tools including protection kits, gloves, goggles, and fire extinguishers to ensure safe handling of drones. • Explain key electrical parameters such as voltage, current, resistance, and power, and measure them using appropriate instruments. 	
Module Structure	
Session 1: Mechanical Tools	
Session 2: Electrical Tools	
Session 3: Safety Tools	
Session 4: Electrical Parameters	

A drone technician requires a variety of specialized tools to assemble, maintain, and repair drones efficiently. These tools can be broadly categorized into mechanical, electrical, and safety tools. Mechanical tools include precision screwdrivers, pliers, soldering stations, and torque wrenches, which are essential for assembling and securing drone components. Electrical tools such as multimeters, oscilloscopes, and battery testers help diagnose and troubleshoot power supply issues. Additionally, software tools like flight controller programming software, calibration tools, and firmware updaters are crucial for optimizing drone performance and

ensuring seamless operation. A well-equipped drone technician must be proficient in using these tools to enhance the durability, efficiency, and safety of drones in various applications.

SESSION 1: MECHANICAL TOOLS

A drone technician needs a variety of tools to effectively maintain, repair, and troubleshoot drones. The specific tools you'll need will vary depending on the type of drone you work with and the tasks you perform. As a drone technician, you may encounter various mechanical tasks that require specific tools for the disassembly, assembly, and maintenance of drone components. Here are some mechanical tools that will be useful for a drone technician:

Screwdrivers: A set of standard and precision screwdrivers for removing and securing screws of different sizes found in drones.



Fig.2.1 Screwdrivers

Nut drivers: Nut drivers of various sizes to handle nuts used in drone assembly.



Fig. 2.2 Nut drivers

Pliers: Needle-nose pliers, regular pliers, and locking pliers (e.g., vise grips) for holding, bending, and manipulating parts.



Fig. 2.3 Pliers

Hex/Allen key set: To handle hex screws commonly used in drone frames and components.



Fig.2.4 Hex/Allen key set

Torx screwdrivers: For Torx screws often found in drone assemblies.



Fig.2.5 Torx screwdrivers

Wrenches: Open-end wrenches or adjustable wrenches for tightening and loosening nuts and bolts.

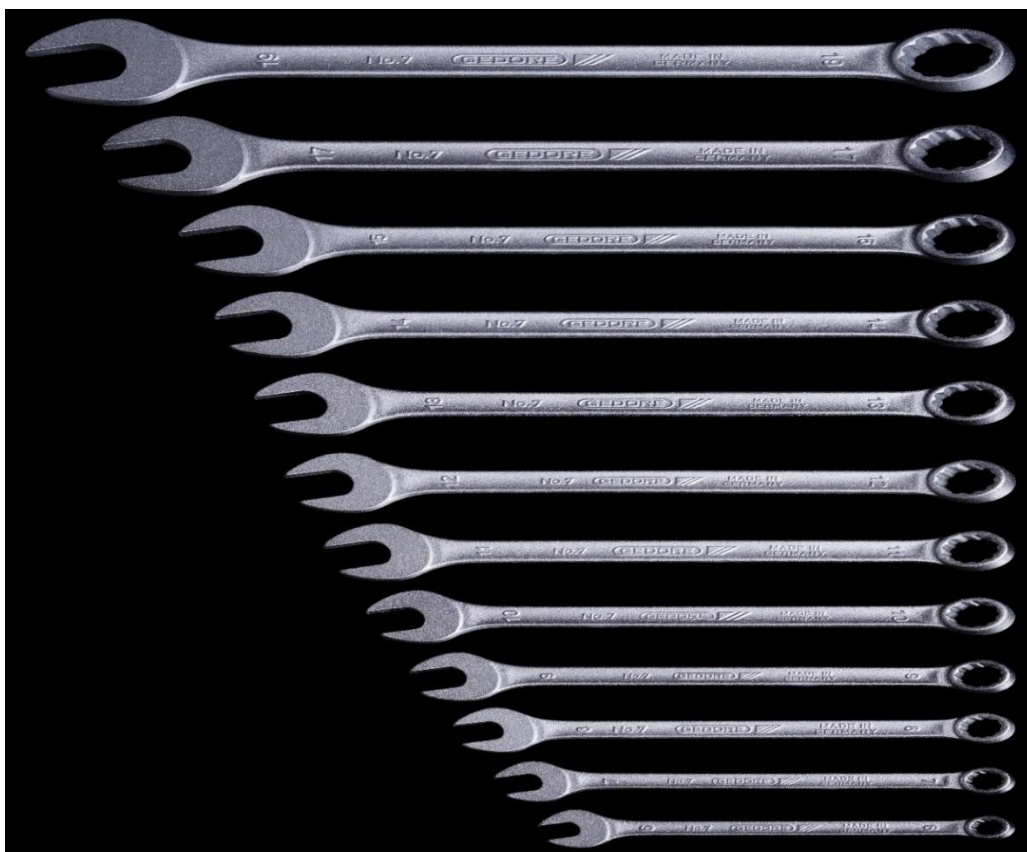

Fig.2.6 Wrenches:

Allen wrench sockets: Useful for accessing recessed hex screws in tight spaces.



Fig.2.8 Allen wrench sockets

Nut and bolt assortment: A collection of various nuts and bolts that are commonly used in drone construction.

Ball-end hex key set: Allows for easier access to screws at an angle.

Ratcheting screwdriver: Provides faster screw driving in tight spaces.



Fig.2.9 Ratcheting screwdriver

Diagonal cutters: For cutting wires, zip ties, and small metal parts.



Fig.2.30 Diagonal cutters

Wire strippers: To strip insulation from wires for soldering and connections.



Fig.2.31 Wire strippers

Needle files: For smoothing and shaping drone components and parts.

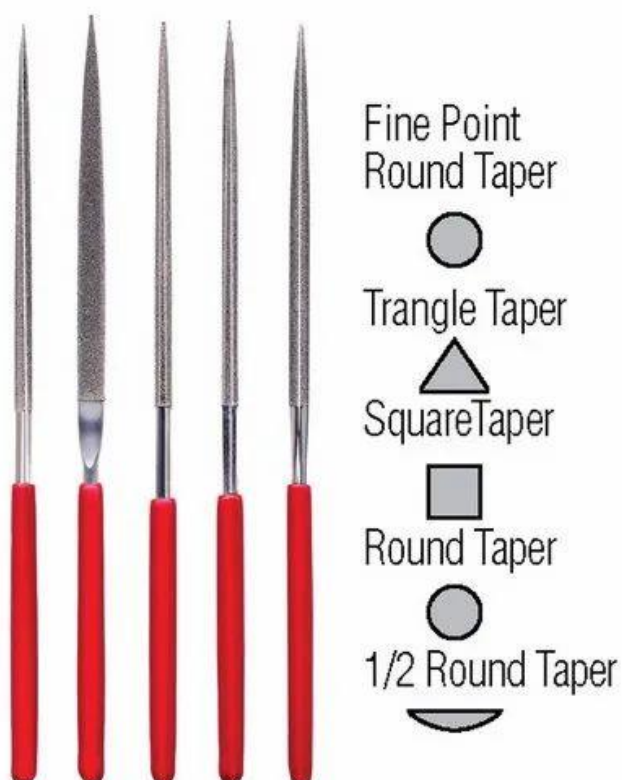

Fig.2.32 Needle files

Digital caliper: To measure precise dimensions and tolerances of drone parts



Fig.2.33 Digital calliper

Digital scale: For weighing components and ensuring proper weight distribution.



Fig.2.34 Digital scale

Thread locker (Loctite): To secure critical screws and prevent them from loosening during flight



Fig.2.35 Thread locker (Loctite)

Thread taps and dies: For repairing damaged threads on drone components.



Fig.2.36 Thread taps and dies

Deburring tool: To remove sharp edges and burrs from metal parts.

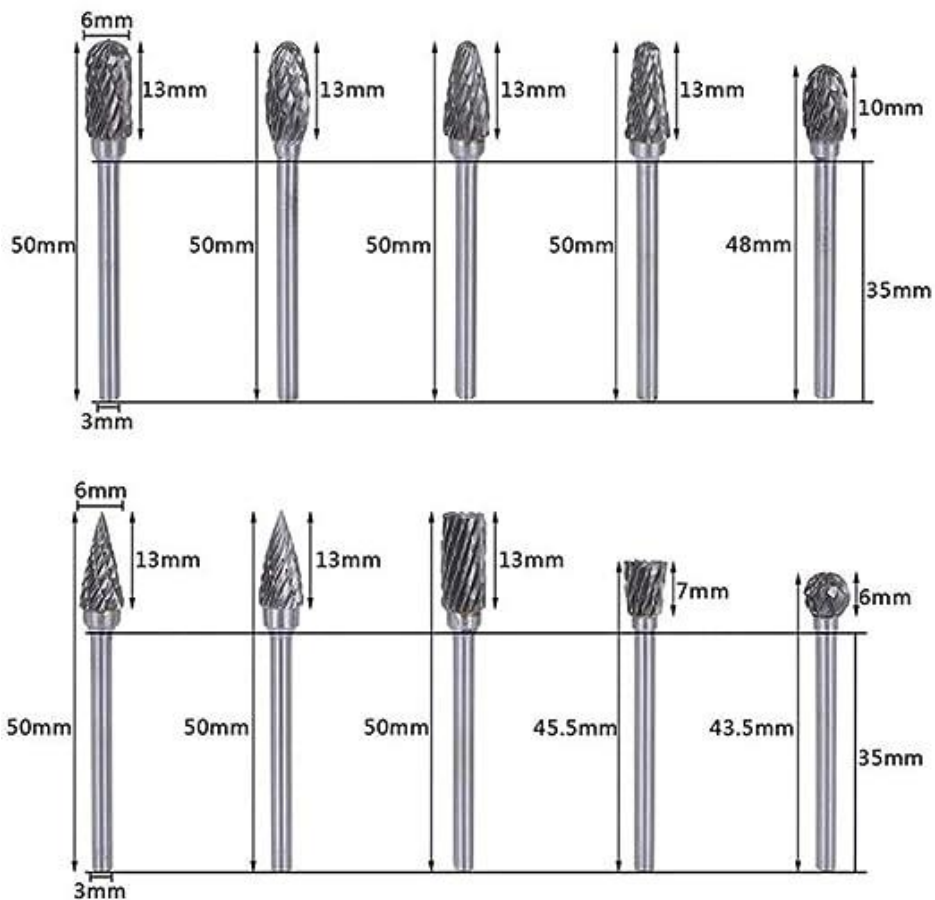

Fig. 2.37 Deburring tool

Vise or clamp: To hold drone components securely during repairs.



Fig.2.38 Vise or clamp

Dremel or rotary tool: Useful for cutting, grinding, and polishing drone parts.



Fig.2.39 Dremel or rotary tool

Heat gun: For heat-shrinking tubing and performing other heat-related tasks.



Fig. 2.40 Heat gun

Lubricants: Appropriate lubricants for gears, bearings, and moving parts.



Fig. 2.41 Lubricants

Practical Exercise

1. Identify the various Mechanical tools for drone service technician

CHECK YOUR PROGRESS**A. Fill in the Blanks**

1. A _____ balancer is used to ensure the propellers are balanced correctly, reducing vibrations during flight.
2. When working with small and delicate drone components in tight spaces, _____ are handy for precise handling.
3. _____ is essential for holding, bending, cutting wires, and gripping small components during drone repairs.
4. To measure distances, dimensions, and clearances in drone components, a drone technician uses _____.
5. When dealing with stubborn propellers, a _____ can be helpful for safe and easy removal.
6. _____ and _____ are essential for maintaining moving parts like motors and gears to reduce friction and wear.
7. A _____ pump helps remove excess solder, allowing for component replacement when working with soldered components.
8. _____ are used to clean and remove debris from hard-to-reach areas and delicate components.
9. _____ are used to ensure screws and other fasteners remain secure during drone flight.
10. A set of _____ is necessary for disassembling and reassembling the drone's frame and components.

B. Multiple Choice Questions

1. Which tool is essential for measuring voltage, current, and resistance in a drone's electrical system?
 - a) Soldering Iron

b) Multimeter

- c) Heat Gun
 - d) Wire Strippers
2. To protect sensitive electronic components from electrostatic discharge (ESD) during drone repairs, a drone technician should use:
- a) Anti-Static Wrist Strap and Mat**
 - b) Battery Voltage Checker
 - c) Wireless Signal Analyzer
 - d) Logic Analyzer
3. What tool is used for making precise connections and repairs in a drone's electrical system?
- a) Heat Gun
 - b) Wire Strippers
 - c) Wire Crimpers**
 - d) Battery Discharger
4. Which tool helps a drone technician visualize and analyze electronic waveforms for troubleshooting complex electrical issues?
- a) Logic Analyzer
 - b) Battery Voltage Checker
 - c) Oscilloscope**
 - d) Deans/T-Plug Connector
5. A drone technician uses a _____ to safely discharge LiPo batteries before storage or disposal.
- a) Soldering Iron
 - b) Multimeter
 - c) Battery Discharger**

- d) Heat Gun
6. When inspecting and identifying damaged components or loose connections on the flight controller board, a drone technician might use a _____. a) Battery Safety Bag **b) Magnifying Glass** c) Logic Analyzer d) Anti-Static Wrist Strap
7. A wireless _____ analyzer is helpful for troubleshooting communication issues between the drone and its remote controller.
- a) Logic
- b) Battery Voltage
- c) Signal**
- d) Oscilloscope
8. Which tool is commonly used for soldering wires or components during drone repairs?
- a) Heat Gun
- b) Wire Crimpers
- c) Soldering Iron**
- d) Battery Discharger
9. Which tools are used for organizing and securing wires and components inside the drone?
- a) Battery Discharger and Logic Analyzer
- b) Multimeter and Oscilloscope
- c) Heat Gun and Wire Strippers
- d) Velcro Straps and Cable Ties**

C. Short Answer Questions

1. How does a multimeter assist a drone service technician in diagnosing electrical issues in a drone?

2. Describe the process of using a multimeter to measure voltage and resistance in a drone's electrical system.
3. Why is a soldering iron an essential tool for a drone service technician?
4. What are the common drone components that might require soldering during repairs?
5. What is the purpose of wire strippers and crimpers in drone repairs?
6. Explain how to use wire strippers and crimpers to repair damaged wires in a drone's power distribution system.
7. Describe the significance of a battery voltage checker for a drone service technician.
8. When and why should a drone service technician use a battery discharger?

SESSION 2: ELECTRICAL TOOLS

As a drone technician, you will often work with electrical components and circuits, making electrical tools essential for your work. Here are some electrical tools that will be useful for a drone technician.

Multimeter: A versatile tool for measuring voltage, current, resistance, and continuity in electrical circuits. It helps diagnose and troubleshoot various electrical issues in drones.

Soldering Iron and Solder: Necessary for soldering and desoldering electronic components, making repairs and modifications to the drone's circuit board.

Wire Cutters/Strippers: For cutting and stripping wires during repairs and maintenance.

Helping Hands: A tool with alligator clips that holds wires and components in place, providing a third hand during soldering or testing.

Heat Shrink Tubing and Heat Gun: To insulate and protect soldered connections.

Tweezers: For handling small electronic components and delicate wires.

Wire Connectors and Terminal Blocks: These are used for making secure and reliable electrical connections.

Crimping Tool: For attaching terminals and connectors to wires.

Electrical Tape: To insulate and protect exposed wires and connections.

Breadboard and Jumper Wires: For prototyping and testing circuits before permanent soldering.

Power Supply: To provide a stable and controlled voltage source for testing and powering drone components.

Oscilloscope: A sophisticated tool to visualize and analyze electronic waveforms and signals.

Logic Analyser: For capturing and analysing digital signals in drone systems.

Anti-static Wrist Strap and Mat: To protect sensitive electronic components from electrostatic discharge.

Battery Voltage Checker: For checking the voltage of drone batteries before and after flights.

Battery Charger: To charge drone batteries during maintenance.

Power Drill and Bits: For making holes in drone frames for mounting components.

Wire Organisers: To keep wires neat and organized during repairs and modifications.

Wire Labels: For labelling wires and connectors to avoid confusion during reassembly.

ESD-safe storage containers: These are used to store and organize small electronic components securely.

Isopropyl Alcohol and Cleaning Materials: For cleaning and removing flux residue after soldering.

Practical Exercise

1. Identify the various electrical tools for technician
2. Describe the significance of a battery voltage checker for a drone service technician.

CHECK YOUR PROGRESS

A. Fill in the Blanks

1. A is an essential tool for measuring voltage, current, and resistance in a drone's electrical system.
2. When dealing with delicate electronic components, it's crucial for a drone technician to use anto protect against electrostatic discharge.

3. For making precise connections and repairs, a drone technician uses aand
4. Anhelps visualize and analyze electronic waveforms and is useful for troubleshooting complex electrical issues in a drone.
5. To safely discharge LiPo batteries before storage or disposal, a drone technician uses a.....
6.connectors are commonly used in drone batteries and power distribution systems, and a crimping tool is used to securely attach them.

ANSWERS

1. Multimeter
2. Anti-Static Wrist Strap and Mat
3. Soldering Iron and Solder
4. Oscilloscope
5. Battery Discharger
6. Deans/T-Plug, Crimping Tool

B. Multiple Choice Questions

1. Which tool is essential for measuring voltage, current, and resistance in a drone's electrical system?
 - a) Soldering Iron
 - b) Multimeter**
 - c) Heat Gun
 - d) Wire Strippers
2. To protect sensitive electronic components from electrostatic discharge (ESD) during drone repairs, a drone technician should use:
 - a) Anti-Static Wrist Strap and Mat**
 - b) Battery Voltage Checker
 - c) Wireless Signal Analyzer
 - d) Logic Analyzer

3. What tool is used for making precise connections and repairs in a drone's electrical system?
 - a) Heat Gun
 - b) Wire Strippers
 - c) **Wire Crimpers**
 - d) Battery Discharger

4. Which tool helps a drone technician visualize and analyze electronic waveforms for troubleshooting complex electrical issues?
 - a) Logic Analyzer
 - b) Battery Voltage Checker
 - c) **Oscilloscope**
 - d) Deans/T-Plug Connector

5. A drone technician uses a _____ to safely discharge LiPo batteries before storage or disposal.
 - a) Soldering Iron
 - b) Multimeter
 - c) **Battery Discharger**
 - d) Heat Gun

C. Short Answer Questions

1. How does a multimeter assist a drone service technician in diagnosing electrical issues in a drone?
2. Describe the process of using a multimeter to measure voltage and resistance in a drone's electrical system.
3. Why is a soldering iron an essential tool for a drone service technician?
4. What are the common drone components that might require soldering during repairs?
5. What is the purpose of wire strippers and crimpers in drone repairs?

6. Explain how to use wire strippers and crimpers to repair damaged wires in a drone's power distribution system.
7. Describe the significance of a battery voltage checker for a drone service technician.
8. When and why should a drone service technician use a battery discharger?

SESSION 3: SAFETY TOOLS FOR DRONE TECHNICIAN

Safety and Protective Equipment

Safety and protective equipment are essential when handling drones, as they contain multiple electrical components, including the controller, battery, and other crucial parts. The presence of high-power batteries and electronic circuits poses risks such as short circuits, overheating, and even potential fire hazards. To ensure safe operation, users should wear insulated gloves while handling batteries, use safety goggles to protect against debris during assembly or flight, and operate drones in designated areas away from obstacles and crowds. Additionally, proper ventilation is necessary when charging batteries to prevent overheating. Adhering to safety guidelines minimizes risks and ensures a secure and efficient drone operation. Repair and operate can be risky. Workers in the drone industry face various risks, like:

- Falls from high
- Electrocution or other electric hazards
- Repetitive stress injuries
- Cuts or sprains

Because of the risks that businesses and workers face, the Occupational Safety and Health Administration requires employers to have safety training and protection for their employees.

The installer needs to visit the site, identify safety risks and develop specific plans to address them. This can include:

- Equipment to use for safe lifting and handling of drone components
- Type and size of ladders and scaffolding
- Fall protection for rooftop work
- Personal protective equipment (PPE) for workers

Table no. 3.2 List of safety tools for use in solar PV installation.









S.No.	Items Description	Application	Sample Photo
1	Safety helmet	Head protection	
2	Safety Goggles with Clear Glass	Eye Protection: Use for a general purpose gives protection from dust	
3	Earplug	Hearing Protection: Protection against noise	
4	Leather cum cotton hand gloves	Hand Protection: For Material Handling	
5	High Visibility Vest	Body protection: For High Visibility	
6	Double Lanyard Full Body Harness	For protection against falls harness while working at a height	
7	Double-density PU sole Safety shoe	Foot protection: For general purpose use	
8	Electrical hand gloves	For Arc flash and cut protection for the voltage >260V <=690V	



Fig. 3.6 Personal protective equipment (PPE) kit for workers

CHECK YOUR PROGRESS**A. Fill in the Blanks**

1. Safety and protective equipment are essential when handling drones, as they contain multiple _____ components. (**electrical**)
2. The presence of high-power _____ and electronic circuits poses risks such as short circuits and overheating. (**batteries**)
3. Users should wear _____ gloves while handling batteries to prevent electrical hazards. (**insulated**)
4. Safety goggles protect against _____ during assembly or flight. (**debris**)
5. Proper _____ is necessary when charging batteries to prevent overheating. (**ventilation**)
6. Workers in the drone industry face risks such as _____ from high places. (**falls**)
7. The Occupational Safety and Health Administration requires employers to have _____ training for employees. (**safety**)
8. A safety _____ protects the head from injuries during drone operations. (**helmet**)
9. _____ hand gloves provide protection against arc flash and high voltage. (**Electrical**)
10. A double lanyard full-body _____ is used for protection against falls. (**harness**)

B. Multiple Choice Questions

1. What is the main purpose of wearing insulated gloves while handling drone batteries?
 - a) To improve grip
 - b) To prevent electrical hazards**
 - c) To keep hands warm
 - d) To avoid getting dirty
2. Why should drones be operated in designated areas?
 - a) To ensure maximum flight time
 - b) To protect against overheating
 - c) To minimize risks of accidents**
 - d) To improve battery life
3. What type of PPE should be worn to protect against falling debris during drone assembly?
 - a) Safety goggles**
 - b) Safety shoes
 - c) Earplugs
 - d) Cotton gloves
4. What is the primary risk when handling high-power drone batteries?
 - a) Freezing
 - b) Overheating and fire hazards**
 - c) Loss of signal
 - d) Poor battery life

5. Why is proper ventilation necessary while charging batteries?
 - a) **To prevent overheating**
 - b) To increase battery lifespan
 - c) To reduce energy consumption
 - d) To ensure faster charging
6. What type of protective equipment is used for high visibility?
 - a) Safety goggles
 - b) **High visibility vest**
 - c) Double lanyard harness
 - d) Earplugs
7. Which of the following safety equipment is used to prevent falls?
 - a) Electrical gloves
 - b) **Full-body harness**
 - c) Safety goggles
 - d) Safety shoes
8. What is the purpose of a safety helmet in drone operations?
 - a) To keep the head cool
 - b) **To protect the head from injuries**
 - c) To improve visibility
 - d) To store tools
9. What is the purpose of earplugs in a drone operation site?
 - a) To enhance focus
 - b) **To reduce noise hazards**
 - c) To prevent electrical shocks
 - d) To improve balance
10. What kind of gloves are recommended for handling high-voltage electrical components?
 - a) Leather gloves
 - b) **Cotton gloves**
 - c) Electrical hand gloves
 - d) Rubber gloves

Short Answer Questions

1. Why is it important to wear safety goggles while working with drones?
2. What are some potential risks associated with handling high-power drone batteries?
3. How does wearing a high-visibility vest contribute to worker safety?
4. What type of personal protective equipment (PPE) is necessary for rooftop work?
5. Why should drone batteries be charged in a well-ventilated area?
6. What kind of gloves should be used when handling electrical components of drones?
7. What are some common risks workers in the drone industry face?
8. How does a double lanyard full-body harness help in drone operations?
9. Why is safety training important in the drone industry?
10. What precautions should be taken when lifting and handling drone components?

SESSION 4: ELECTRICAL PARAMETERS

We use electricity in our daily life without electricity it is very difficult to live. so we need to know some electrical parameters. As a solar pump technician, one should know all parameters/terminology related to electricity.

Electrical Parameters of Electricity

Electricity is the Flow of Electrons. Electricity uses in our daily life but many of us do not know its basic terms and people find it difficult to learn about electricity main terms of electricity are as follows-

Current (I)

The flow of electrons (amount of charge) through a wire is called current. The SI unit of current is Ampere (A).

$$\text{current}(I) = \frac{\text{charge}(Q)}{\text{time}(t)}$$

1 Ampere means 10^{18} electrons flow in one second in a wire

Voltage (V)

The pressure that pushes the charge (electrons) in a wire is called voltage. Voltage is measured in volts. in our home's electrical circuit, we get a voltage level of 230 volts. In practice, we deal with a wide range of voltage levels; from very small to very large voltage level.

Resistance(R) Resistance is a measure of the oppose to current flow in an electrical circuit. Resistance is measured in ohms, symbolized by the Greek letter omega (Ω).

$$\text{Voltage(Volt)} = \text{resistance (ohms)} \times \text{current(ampere)}$$

$$V = R \times I$$

Electric Power (P)

The capability to do work in a particular way is called power. Electric power is the rate, per unit time at which electrical energy is transferred by an

electric circuit. The SI unit of power is joule/second or watt.

$$\text{Electric Power(watt)} = \text{voltage(volt)} \times \text{current(ampere)}$$

$$1 \text{ watt} = \frac{1 \text{ joule}}{1 \text{ second}}$$

For example: for a 100-watt bulb, a voltage of 230 volts is applied. What is the value of current?

Solution: $\text{Electric Power(watt)} = \text{voltage(volt)} \times \text{current(ampere)}$

$$\text{Current} = \text{electric power} / \text{voltage}$$

$$\text{Current} = 100 \text{ watt} / 230 \text{ volt}$$

$$\text{Current (I)} =$$

$$0.4347 \text{ ampere}$$

Ans.

Energy

The ability to do work for an object is called energy. The unit of energy is the joule. Where

$$1 \text{ joule} = 1 \text{ kg} - \text{m}^2 / \text{sec}^2$$

AC AND DC CURRENT

DC CURRENT: the direction of the current does not change with time. The DC is a constant current. Therefore, the symbol of the DC is a straight line. Direct current may be converted from an alternating current supply by use of a rectifier, which contains electronic elements or electromechanical elements that allow current to flow only in one direction. Direct current may be converted into an alternating current with the help of an inverter. The symbol of the DC current is as shown in the figure below.



Fig.3.35: DC current symbols

A PV module produces DC power or DC current, or DC voltage the DC current flows in DC load or a DC circuits.

AC CURRENT: Electric charge in alternating current (AC), on the other hand, changes direction periodically. The voltage in AC circuits also periodically reverses because of the current change direction. AC current is generally used to power homes and businesses and is also present when audio and radio signals are carried on electrical wires. A rectifier is an electrical device that converts alternating current (AC).

The symbol of AC current is as shown in the figure below.

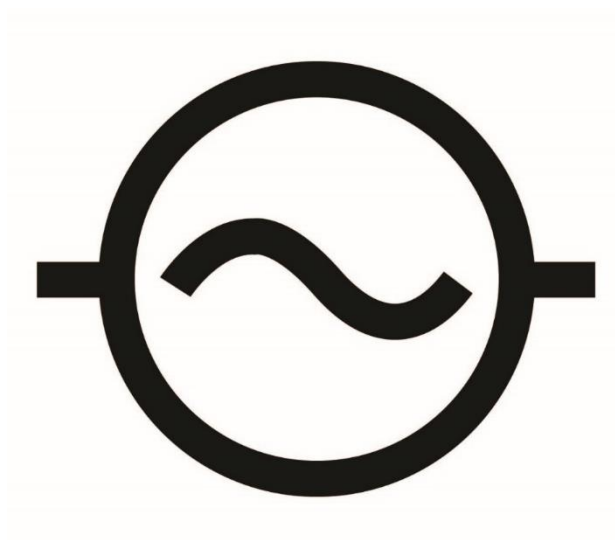

Fig.3.36 AC current symbol

CHECK YOUR PROGRESS**Fill in the Blanks**

1. The SI unit of current is _____. (Ampere)
2. The pressure that pushes the charge in a wire is called _____. (Voltage)
3. Resistance is measured in _____, symbolized by the Greek letter omega (Ω). (Ohms)
4. Electric power is the rate at which _____ energy is transferred by an electric circuit. (Electrical)
5. The unit of electric power is _____. (Watt)
6. The ability to do work for an object is called _____. (Energy)
7. A PV module produces _____ power. (DC)
8. The direction of _____ current does not change with time. (DC)
9. The voltage in an _____ circuit periodically reverses because the current changes direction. (AC)
10. The device used to convert AC to DC is called a _____. (Rectifier)

Multiple Choice Questions

1. What is the SI unit of current?
 - a) Volt
 - b) Ohm
 - c) Ampere**
 - d) Joule
2. The pressure that pushes electrons in a wire is called:
 - a) Resistance
 - b) Voltage**
 - c) Power
 - d) Energy
3. The opposition to the flow of current in an electrical circuit is called:
 - a) Current
 - b) Voltage
 - c) Resistance**
 - d) Power
4. What is the formula for electric power?
 - a) $P = V \times I$**
 - b) $P = I / R$
 - c) $P = V \times R$
 - d) $P = I^2 \times R$
5. 1 Watt is equal to:
 - a) 1 Joule per second**
 - b) 1 Ampere per second

- c) 1 Volt per second
 - d) 1 Ohm per second
6. In DC current, the direction of current:
- a) Reverses periodically
 - b) Does not change**
 - c) Changes continuously
 - d) Flows randomly
7. What device is used to convert AC to DC?
- a) Inverter
 - b) Transformer
 - c) Rectifier**
 - d) Resistor
8. Which type of current is used to power homes and businesses?
- a) DC
 - b) AC**
 - c) Both AC and DC
 - d) Neither AC nor DC
9. A PV module produces which type of current?
- a) AC
 - b) DC**
 - c) Both AC and DC
 - d) None of the above
10. The voltage level supplied to homes in an electrical circuit is usually:
- a) 110V
 - b) 230V**
 - c) 12V
 - d) 400V

Short Answer Questions

1. What is the definition of electric current?
2. How is voltage measured, and what is its unit?
3. What is the relationship between voltage, current, and resistance?
4. Define electric power and its SI unit.
5. How can you calculate the current in a circuit if voltage and power are known?
6. What is the difference between AC and DC current?

MODULE 3	MAJOR COMPONENTS OF DRONE
Module Overview	
<p>This module provides a detailed understanding of the essential components that make up a drone, including mechanical, electrical, and electronic parts. It also covers the principles of take-off and landing, which are crucial for safe drone operation.</p> <p>Major Components of the Drone – Introduces key structural elements such as the frame, propellers, motors, flight controller, and power source. Electric and Electronic Components of the Drone – Explores batteries, ESC (Electronic Speed Controller), GPS, sensors, and communication systems that enable drone functionality. Take-off and Landings of Drone – Covers the science behind drone flight stability, lift generation, safe take-off, landing procedures, and common challenges.</p>	
Learning Outcomes	
<p>After completing this module, you will be able to:</p> <ul style="list-style-type: none"> • Identify and describe the major structural components of a drone, including the frame, propellers, motors, and flight controller. • Understand the role of electric and electronic components such as batteries, ESCs, GPS, sensors, and communication systems in drone operations. • Explain the principles of drone takeoff and landing, including stability, lift generation, and safe flight procedures. • Recognize common issues in drone components. 	
Module Structure	
Session 1: Major components of the drone	
Session 2: Electric and electronic components of the drone	
Session 3: Take off and landings of drone	

A drone is a sophisticated system that integrates hardware, software, and mechanical components to achieve seamless functionality. From an engineering perspective, the major hardware components include the flight controller, electronic speed controllers (ESCs), motors, propellers, battery, GPS module, and various sensors such as gyroscopes and accelerometers. The software architecture, including firmware and flight control algorithms,

plays a crucial role in stabilizing and controlling the drone's movement. Mechanical elements, such as the airframe and landing gear, provide structural integrity and aerodynamics. A well-balanced integration of these three aspects ensures optimal performance, efficiency, and reliability in drone operation.

SESSION 1: MAJOR COMPONENTS OF DRONE

Drone Motor

Drones (quadcopters) have two clockwise motors and two counter clockwise motors to equalise the turning force produced by the rotating propellers. This is because of Newton's Third Law, which states that for every action, there is an equal and opposite reaction. So, having an equal number of motors counteracting each other provides stability through equalising the turning force. This is why on helicopters, there is a tail rotor to counteract the turning force from the single main rotor.



Fig.3.1 Drone Motor

Drone Propellers

As drones (quadcopters) have two counter-clockwise motors and clockwise motors, they also have two different propellers, one for each motor direction.

Each propeller rotates, pushing the air down on the airfoil surface, creating an area of lower pressure on top of the propeller and an area of higher pressure below it, resulting in a difference of pressure, thus pushing the drone up.



Fig.3.2

Drone Flight Controller

This is the brain of the drone. The flight controller takes in inputs from the GPS module, compass, obstacle avoidance sensors, and the remote controller and processes it into information that is given out to the ESCs to control the motors. An example of this is seen when a drone is hovering during windy conditions. In the past, or if you have a cheap drone, it will just drift around as there are no sensors relaying information about the drone's location and how to correct for these changes. In this drone, however, the drone knows its exact location from the GPS and the downward vision sensors, so even if wind is blowing, it will stay in its exact place. This is because the flight controller sends the proper instructions to the ESCs and interns the motors to compensate for the wind factor.

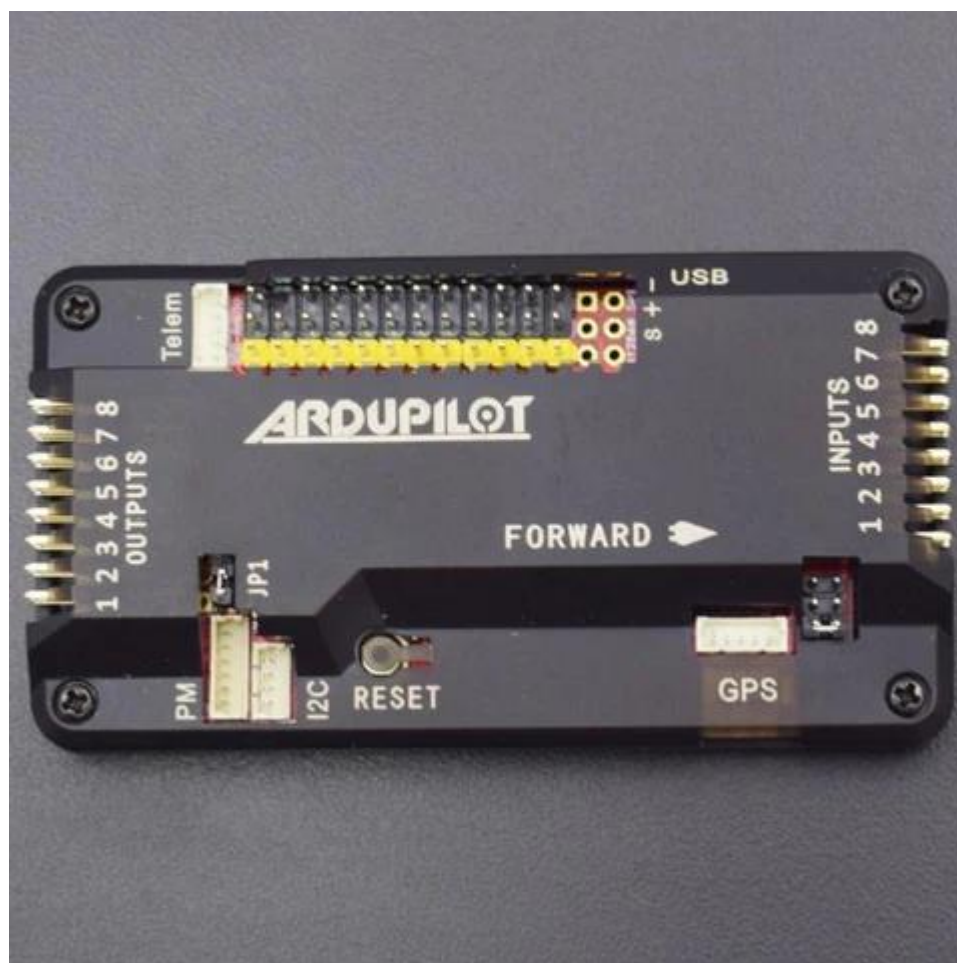

Fig.3.3 **Flight Controller**

GPS Module

The global positioning satellite module uses two different global positioning systems to pinpoint the drone's location. It uses the Russian network known as GLONASS (Globalnaya Navigazionnaya Sputnikovaya Sistema), which is comprised of 24 satellites orbiting Earth. This is used in conjunction with the United States network consisting of 31 satellites. These satellites transmit information about their location to Earth's surface. These signals travel at the speed of light and are read by the GPS module on the drone. From there, the drone calculates its geolocation based on the amount of time it took for the signals to arrive from the various satellites. These global positioning satellites give the drone the ability to understand where it is on Earth and maintain its position.

Electronic Speed Controller (ESC)



Fig.3.4 **Electronic Speed Controller (ESC)**

The ESCs are connected to the power distribution board (the battery) and the flight controller. As the ESCs receive signals from the flight controller, it changes the amount of power given to each of the motors.

Power Port Module

This monitors the amount of power coming from the battery and distributes it to the drone's ESCs and the flight controller.

Obstacle Avoidance Sensors

This drone has stereo vision sensors on the front and the bottom; these sensors work in pairs, just like your eyes. These sensors calculate depth by identifying which image pixels from each sensor correspond to the same point. From this, the drone can calculate the distance it is from the object in front of it as the distance between the sensors is constant. In other words, the drone solves the Pythagorean Theorem repeatedly to calculate the distance an object is from the drone.

3-Axis Gimbal

This is how drone footage is kept so still and stabilized. A motor is placed on the 3 different axes around the camera. When the sensors detect motion on

any of these axes, the motors counteract the motion to cancel it. This happens almost instantly as thousands of calculations are executed to provide smooth footage.



Fig.3.53-Axis Gimbal

Drone Camera

A lens opens at the front of the camera and light streams in. An imaging sensor captures the incoming light rays and then processes it into a digital image.

Drone Battery

These batteries are ‘intelligent’, meaning that they have over-charge protection, temperature data, charge cycle history, and communicate power output to the drone. This is to ensure the battery is safe to use repeatedly and so that there are no problems during flight.

Drone Antennas

Inside the legs of the drone is the transmission system which relays information from the drone to the controller and from the controller to the drone. Also, in the legs of this drone is two compass sensors which relay its direction to the flight controller.

Downward Ultrasonic Obstacle Avoidance Sensor

One sensor sends out a high-frequency sound pulse and the other sensor receives the pulse. Based on the amount of time between sending the pulse and receiving the pulse the drone calculates the height of the drone off the ground.

Flight LED

These flash various colors to show the user what direction the drone is facing. The two flashing red lights show the front of the drone (the direction the camera is facing). The two green flashing lights are the back of the drone.

Joysticks

These translate the physical movement of the sticks into information that the controller can use to communicate with the drone. The left joystick moves the drone up and down and does pan right and pan left. The right joystick moves the drone forward and backward and does drift right and drift left.

Main Remote Controller Board

This receives information from the drone about its location, altitude, and what the camera is seeing. It also takes inputs from the joysticks and sends the commands to the flight controller.

Main Camera Board

This processes information from the imaging sensor and gimbal motors to ensure stable footage. This board also processes the camera information and writes the image to the micro SD card.

Frame: The frame is the basic structure of the drone, providing a rigid platform that holds all the components together. Frames are typically made of lightweight materials such as carbon fiber, plastic, or aluminium.

Practical Exercise

1. Identify the various major components of a drone.

CHECK YOUR PROGRESS

A. Fill in the Blanks

1. The..... is the basic structure of the drone, providing a rigid platform that holds all the components together. **(Frame)**
2. are rotating blades that generate the lift required for the drone to fly. **(Propellers)**
3. are electric or brushless DC motors that drive the propellers, converting electrical energy into mechanical rotational motion to generate lift and control the drone's movement. **(Motors)**
4. are electronic devices that control the speed and direction of the motors, allowing the flight controller to adjust the drone's stability and orientation. **(Electronic Speed Controllers (ESCs))**
5. The is the brain of the drone, containing sensors such as gyroscopes, accelerometers, and sometimes GPS. It processes data from these sensors to stabilize the drone and execute flight commands. **(Flight Controller)**

B. Multiple Choice Questions

1. What is the purpose of the frame in a drone?
 - a) To provide power to the motors
 - b) To stabilize the drone during flight
 - c) To hold all the components together**
 - d) To control the camera gimbal

2. What component generates lift for the drone?
 - a) Motors
 - b) Propellers**
 - c) Flight Controller
 - d) Electronic Speed Controllers (ESCs)
3. Which of the following materials is commonly used to construct drone frames due to its lightweight and strong properties?
 - a) Steel
 - b) Wood
 - c) Plastic
 - d) Aluminum**
4. What is the role of Electronic Speed Controllers (ESCs) in a drone?
 - a) To process data from sensors
 - b) To stabilize the drone during flight
 - c) To generate lift for the drone
 - d) To control the speed and direction of the motors**
5. What is the brain of the drone that processes data from sensors and stabilizes the drone during flight?
 - a) GPS Module
 - b) Remote Controller
 - c) Flight Controller**
 - d) Telemetry System
6. Which type of battery is commonly used as the power source for drones?
 - a) Lead-Acid Battery
 - b) Alkaline Battery
 - c) Lithium-Polymer (LiPo) Battery**
 - d) Nickel-Cadmium (NiCd) Battery
7. What is the handheld device used by the operator to control the drone's flight?
 - a) Flight Controller
 - b) Telemetry System

c) Remote Controller

d) GPS Module

8. In camera drones, what component keeps the camera steady during flight to capture smooth footage?

a) GPS Module

b) Flight Controller

c) Propellers

d) Gimbal

9. What feature does a GPS module add to a drone's navigational capabilities?

a) Return-to-Home function

b) Camera stabilization

c) Motor control

d) Radio communication

10. Which component of an autonomous drone enables it to perform tasks without constant human intervention?

a) Remote Controller

b) Flight Controller

c) Onboard Computer

d) Telemetry System

C. Short Answer Questions

1. What is the purpose of the frame in a drone, and what materials are commonly used to construct it?
2. How do propellers generate lift for the drone, and how does the number of propellers affect the drone's flight characteristics?
3. What is the function of electronic speed controllers (ESCs) in a drone, and how do they work with the flight controller?
4. Describe the role of the flight controller in a drone's operation and its importance in stabilizing the drone during flight.
5. What type of battery is typically used in drones, and what is its role as the power source for the motors and electronics?
6. How does the remote controller (transmitter) communicate with the drone, and what commands can the operator send to control the drone's flight?

SESSION 2: ELECTRONIC COMPONENTS OF DRONE

Electronic components play a vital role in the operation and control of a drone, ensuring its stability, navigation, and functionality. Key components include microcontrollers or flight controllers, which process sensor data and execute flight commands, and inertial measurement units (IMUs) that provide real-time orientation and motion data. Electronic speed controllers (ESCs) regulate motor speeds, enabling precise manoeuvrability, while GPS modules assist in autonomous navigation and positioning. Additionally, sensors such as gyroscopes, accelerometers, barometers, and magnetometers contribute to altitude control, balance, and obstacle detection. Power management systems, including batteries and voltage regulators, ensure efficient energy distribution, while communication modules like radio transmitters, receivers, and telemetry units facilitate remote operation. Together, these electronic components form the backbone of a drone, enabling seamless flight control, real-time data processing, and integration with advanced technologies such as AI and automation. Here are some of the key electronic components found in drones:

Flight Controller: The flight controller is the brain of the drone, containing a microprocessor and various sensors like gyroscopes, accelerometers, and sometimes magnetometers. It processes data from these sensors to stabilize the drone during flight and execute flight commands based on input from the remote controller or autonomous systems.

Electronic Speed Controllers (ESCs): ESCs are devices that control the speed and direction of the drone's motors. They receive signals from the flight controller and adjust the motor's RPM accordingly, allowing the drone to move in different directions.

Receiver and Transmitter: Drones use a radio transmitter and a receiver to establish communication between the operator (pilot) and the drone. The transmitter sends control signals, while the receiver receives and interprets these signals to control the drone's movement.

GPS Module: GPS (Global Positioning System) modules are commonly integrated into drones to provide accurate positioning data. They enable features like GPS-assisted flight, return-to-home, and waypoint navigation.

Telemetry System: Professional and advanced drones often have telemetry systems that allow real-time data transmission between the drone and the operator or ground station. Telemetry provides crucial information about the drone's status, battery level, altitude, and other important metrics.

On board Computer: In more advanced drones, an onboard computer with built-in processing capabilities may handle additional tasks, such as autonomous flight, obstacle avoidance, and complex flight patterns.

Sensors: Drones can be equipped with various sensors, such as GPS, barometers, magnetometers, optical sensors, and more. These sensors provide essential data for navigation, altitude control, collision avoidance, and other functionalities.

Camera and Camera Control: Camera drones are equipped with electronic components such as the camera sensor, image processing chips, and camera control systems. These components work together to capture high-quality images and videos during flight.

LED Lights: LEDs (Light Emitting Diodes) are often integrated into drones for visual cues and to enhance visibility during low-light conditions. They can serve as status indicators for various drone functions.

Wi-Fi and Communication Modules: Consumer drones often have Wi-Fi modules for connecting to smartphones or tablets, allowing for live video streaming and control through a mobile app. Advanced drones may use other communication modules for data exchange with ground stations or other drones.

Microcontrollers and Microprocessors: These electronic components handle various control functions and data processing within the drone's flight controller and onboard computer.

Gimbal Control: Camera drones equipped with gimbals have electronic components to control the gimbal's movement and stabilization, ensuring smooth and stable footage during flight.

CHECK YOUR PROGRESS

A. Fill in the Blanks

1. The _____ is the brain of the drone, processing sensor data and stabilizing flight. (**Flight Controller**)
2. _____ control the speed and direction of a drone's motors by adjusting their RPM. (**Electronic Speed Controllers (ESCs)**)
3. A drone's _____ and _____ enable communication between the pilot and the drone. (**Transmitter, Receiver**)
4. The _____ module provides accurate positioning data for GPS-assisted flight. (**GPS**)
5. The _____ system allows real-time data transmission between the drone and the ground station. (**Telemetry**)
6. Advanced drones may have an onboard _____ to handle autonomous flight and obstacle avoidance. (**Computer**)
7. _____ are used in drones for navigation, altitude control, and collision avoidance. (**Sensors**)
8. The _____ stabilizes a camera drone's movement to capture smooth footage. (**Gimbal**)
9. _____ modules allow drones to connect to mobile apps for live video streaming and control. (**Wi-Fi**)
10. _____ LEDs on drones provide _____ cues and enhance visibility in low-light conditions. (**Visual**)

B. Multiple Choice Questions

1. What is the primary function of a flight controller in a drone?
 - a) To provide power to the drone
 - b) To stabilize flight and process sensor data**

- c) To control the camera
 - d) To store flight logs
2. Which component controls the speed and direction of a drone's motors?
- a) Flight Controller
 - b) Electronic Speed Controllers (ESCs)**
 - c) GPS Module
 - d) Telemetry System
3. The GPS module in a drone is used for:
- a) Capturing images
 - b) Providing accurate positioning data**
 - c) Enhancing video quality
 - d) Reducing battery consumption
4. What role does a telemetry system play in a drone?
- a) It stabilizes the drone
 - b) It controls motor speeds
 - c) It allows real-time data transmission**
 - d) It enhances camera focus
5. Which of the following components is responsible for communication between the drone and the operator?
- a) ESC
 - b) Receiver and Transmitter**
 - c) Gimbal
 - d) Camera Sensor
6. What is the function of a gimbal in a drone?
- a) To stabilize the drone
 - b) To control motor speeds
 - c) To ensure smooth and stable camera movement**
 - d) To transmit telemetry data
7. What type of sensors are commonly used for drone altitude control?
- a) Accelerometer
 - b) Gyroscope

c) Barometer

d) Magnetometer

8. Why do drones have LED lights?

a) To provide additional power

b) To enhance visibility and indicate status

c) To control motor speed

d) To transmit data wirelessly

9. Which electronic component enables drones to connect to mobile devices for live video streaming?

a) GPS Module

b) Wi-Fi Module

c) ESC

d) Barometer

10. In professional drones, an onboard computer is used for:

a) Processing complex flight patterns and autonomous navigation

b) Charging the battery

c) Controlling motor speeds manually

d) Storing images and videos

C. Short Answer Questions

1. What is the function of a flight controller in a drone?
2. How do Electronic Speed Controllers (ESCs) contribute to drone maneuverability?
3. What role does a GPS module play in drone navigation?
4. Why is telemetry important in advanced drones?
5. What are some common sensors used in drones, and what are their functions?
6. How does a gimbal improve the quality of aerial photography and videography?
7. What is the purpose of LED lights on a drone?
8. How does a receiver and transmitter help in drone operation?

SESSION 3: TAKE-OFF AND LANDING OF DRONE

Takeoff and landing are critical phases of a drone's flight, requiring precision and control to ensure a safe and successful mission. During takeoff, the drone must achieve stable lift while maintaining balance and avoiding sudden jerks or instability. Proper calibration of sensors, GPS lock, and battery checks are essential before initiating the ascent. Similarly, landing demands careful execution to prevent damage to the drone or its surroundings. Factors such as wind conditions, terrain, and battery levels must be considered to achieve a smooth descent. Utilizing automated landing features, visual markers, or manual piloting techniques can enhance accuracy and reliability. Mastering these phases minimizes risks, enhances flight efficiency, and prolongs the drone's operational lifespan. Let's delve into the steps involved in the takeoff and landing process of a drone:

TAKEOFF

The takeoff of a drone is a critical phase that requires precision and stability. Before takeoff, the drone undergoes a pre-flight check to ensure all components, including the battery, propellers, and sensors, are functioning correctly. Once powered on, the drone's flight controller stabilizes its position using gyroscopes and accelerometers. The motors gradually increase speed, generating enough thrust to overcome gravity and lift the drone into the air. Depending on the type, a drone can take off manually or autonomously using GPS-assisted flight modes. A smooth and controlled takeoff is essential to avoid instability and ensure safe operation, especially in varying environmental conditions.

Preflight Checks: Before takeoff, conduct a thorough preflight check to ensure that all components, including the motors, propellers, flight controller, and battery, are functioning correctly.

Flat and Open Area: Choose a flat and open area, free from obstacles and people, for takeoff. Ensure that the drone's launchpad is stable and suitable for the drone's size.

Battery Check: Verify that the drone's battery has sufficient charge to complete the intended flight safely. Avoid launching with a critically low battery.

Positioning: Place the drone on the launchpad, aligning it to face away from you, and keep a safe distance from the propellers.

Arm the Motors: Following the manufacturer's guidelines, arm the drone's motors. This usually involves a specific combination of control inputs on the remote controller.

Smooth Takeoff: Gradually increase the throttle (thrust) on the remote controller to lift the drone off the ground. Avoid sudden movements to maintain stability.

Altitude Control: Once airborne, maintain a steady ascent to a safe altitude. Be mindful of any obstacles and airspace regulations during the ascent.

LANDING

The landing of a drone is a critical phase that requires precision and control to ensure a safe touchdown. Depending on the drone type and operational conditions, landing can be performed manually by the pilot or autonomously using sensors and GPS-assisted technology. Fixed-wing drones typically require a runway or parachute-based landing, while multirotor drones descend vertically and can land on diverse surfaces. Advanced drones utilize vision-based landing systems, LiDAR, or ultrasonic sensors to detect the terrain and avoid obstacles. Factors like wind speed, battery levels, and ground stability play a crucial role in a smooth landing. Proper landing procedures help prevent damage to the drone's frame, propellers, and onboard electronics, ensuring its longevity and continued operational efficiency.

Altitude Adjustment: Before initiating the landing process, ensure the drone is at a safe altitude and has sufficient battery for the descent and landing.

Select Landing Zone: Choose a suitable landing zone, free from obstacles and hazards. Aim for a flat and open area that allows a smooth touchdown.

Descent Planning: Plan a gentle descent path towards the landing zone. Avoid rapid descent or sharp movements to prevent instability.

Land with Caution: Gradually reduce the throttle to bring the drone down gently. Avoid cutting power suddenly, as it can lead to hard landings and potential damage.

Land Vertically: For most drones, land vertically, ensuring the drone's descent is vertical and controlled.

Throttle Cut-off: After the drone safely touches the ground, cut off the throttle to stop the motors. This disarms the drone and prevents accidental takeoff.

Power Off: Once the drone is safely landed and disarmed, power off the remote controller and any connected devices.

Post-flight Check: After landing, inspect the drone for any damage or issues. Perform a post-flight check to ensure that all components are in proper working condition.

It is crucial to practice takeoffs and landings carefully and become proficient in these maneuvers to ensure safe and smooth flights. Always follow the manufacturer's guidelines and local regulations when operating a drone.

Practical Exercise

1. Record videos of both a manual and an automated take-off and landing. Compare and contrast the two approaches.
2. Perform a controlled manual landing of a drone, ensuring smooth descent and touchdown.

CHECK YOUR PROGRESS

A. Fill in the Blanks

1. Before takeoff, a drone undergoes a _____ to ensure all components are functioning correctly. (**pre-flight check**)
2. A drone's _____ stabilizes its position using gyroscopes and accelerometers. (**flight controller**)
3. The motors increase speed to generate enough _____ to overcome gravity and lift the drone. (**thrust**)
4. A **flat and open area** should be chosen for takeoff to ensure safety.
5. Before takeoff, verify that the drone's _____ has sufficient charge for the intended flight. (**battery**)
6. When arming the motors, follow the _____ to ensure proper operation. (**manufacturer's guidelines**)
7. _____ is essential to maintain a steady ascent and avoid obstacles. (**Altitude control**)
8. Fixed-wing drones typically require a _____ or parachute-based landing. (**runway**)
9. _____ can help advanced drones detect terrain and avoid obstacles during landing. (**Ultrasonic sensors**)
10. A post-flight check is necessary to inspect the drone for _____ or issues. (**damage**)

Multiple Choice Questions

1. What is the purpose of a pre-flight check?
 - a) To check the weather conditions
 - b) To ensure all drone components are functioning correctly**

- c) To test the drone's camera
 - d) To adjust the landing gear
2. What helps a drone maintain stability during takeoff?
- a) GPS
 - b) Barometer
 - c) Gyroscopes and accelerometers**
 - d) Altimeter
3. Which of the following is NOT part of a pre-flight check?
- a) Checking the battery level
 - b) Inspecting the propellers
 - c) Turning off GPS before takeoff**
 - d) Verifying sensor functionality
4. Why is a flat and open area recommended for takeoff?
- a) To allow the drone to capture better images
 - b) To ensure a stable and safe launch**
 - c) To increase flight time
 - d) To test wind resistance
5. How should a pilot perform a smooth takeoff?
- a) Increase the throttle suddenly
 - b) Gradually increase the throttle**
 - c) Hold the drone and throw it in the air
 - d) Decrease throttle before takeoff
6. What is the best way to ensure a smooth landing?
- a) Cut off the throttle immediately
 - b) Descend rapidly to save battery
 - c) Plan a gentle descent path**
 - d) Keep the drone hovering for a long time before landing
7. Which component helps detect terrain during an advanced drone landing?
- a) Gyroscope
 - b) LiDAR**
 - c) Battery
 - d) Propellers

8. Why is it important to check the drone's battery before landing?
- a) To extend flight time
 - b) To ensure sufficient charge for a safe descent**
 - c) To improve video quality
 - d) To reset the flight controller
9. What should be done immediately after the drone lands safely?
- a) Increase throttle for a quick takeoff
 - b) Power off the drone and remote controller**
 - c) Leave the motors running for cooling
 - d) Move the drone to a different location
10. What should be performed after every flight?
- a) Battery recharge
 - b) Post-flight check**
 - c) Immediate takeoff again
 - d) Firmware update

Short Answer Questions

1. Why is a pre-flight check important before taking off?
2. How do gyroscopes and accelerometers help in stabilizing a drone?
3. What are the key factors to consider when selecting a takeoff location?
4. Why should the drone's battery be checked before flight?
5. What are the steps involved in arming a drone's motors?
6. How should a drone take off smoothly and maintain stability?
7. What are the different types of drone landing methods?
8. What should be included in a post-flight check after landing?

MODULE 4	WORK AND SAFETY
Module Overview	
<p>This module focuses on workplace safety, hazard identification, personal protective equipment (PPE), and waste management in drone servicing and operations. It equips learners with essential safety knowledge to ensure a secure and efficient working environment.</p> <p>Toolbox Talk and Different Types of Hazards – Introduces the concept of Toolbox Talks (daily safety briefings) and covers various workplace hazards such as electrical, mechanical, environmental, and operational risks in drone servicing.</p> <p>PPE Kit Safety Tools and Safety – Explains the importance of Personal Protective Equipment (PPE), including gloves, safety goggles, ESD protection kits, and fire-resistant clothing, ensuring safety while handling drones and electrical components.</p> <p>Waste Management Concepts – Covers proper disposal and recycling of drone components, including batteries, electronic waste (e-waste), and hazardous materials, promoting environmental sustainability in drone operations.</p>	
Learning Outcomes	
<p>After completing this module, you will be able to:</p> <ul style="list-style-type: none"> • Understand the importance of Toolbox Talks and identify different types of workplace hazards in drone servicing. • Recognize the essential PPE tools required for safety while handling drones and electrical components. • Apply workplace safety measures to prevent accidents, injuries, and operational risks. • Implement proper waste management techniques, including handling and disposing of batteries, electronic waste, and hazardous materials. 	
Module Structure	
Session 1: Tools Box Talk and Different Types of Hazards	
Session 2: PPE Kit Safety Tools and Safety	
Session 3: Waste Management Concepts	

Ensuring workplace safety is essential in any technical or industrial setting. This unit covers the fundamental principles of maintaining a safe working environment, including the identification of potential hazards, proper handling of tools and equipment, and adherence to safety protocols. It emphasizes the importance of personal protective equipment (PPE), emergency response procedures, and industry-specific safety regulations. Additionally, the unit highlights risk assessment techniques and best practices for preventing accidents, ensuring both personal and workplace safety. By understanding and implementing these safety measures, workers can create a secure and efficient work environment, reducing the likelihood of injuries and operational disruptions.

SESSION 1: TOOLS BOX TALK AND DIFFERENT TYPES OF HAZARDS

Toolbox Talks are short safety meetings conducted to discuss specific workplace hazards and best practices to mitigate risks. As drone technicians, we rely heavily on various tools to perform our tasks efficiently. However, it's crucial to use these tools safely to prevent accidents and maintain their longevity. Let's discuss some essential safety tips and maintenance practices for our tools.

1. **Personal Protective Equipment (PPE):** Always wear appropriate PPE when using tools. This may include safety glasses, gloves, ear protection, and steel-toed boots, depending on the task and the tools being used. PPE can protect us from potential injuries and hazards.
2. **Inspect Tools Before Use:** Before using any tool, inspect it for damage or wear. Make sure all moving parts are functioning correctly and there are no loose handles or blades. Report any damaged tools to the supervisor immediately.
3. **Proper Tool Storage:** Store tools in designated areas when not in use. Avoid leaving them lying around, as this can lead to tripping hazards and tool damage. Organized tool storage ensures easy access and reduces the risk of accidents.

4. **Correct Tool for the Job:** Use the right tool for the specific task. Using improper tools may lead to accidents or damage to both the tool and the equipment we are working on.
5. **Follow Manufacturer's Guidelines:** Adhere to the manufacturer's instructions and guidelines for tool usage and maintenance. This includes recommended settings, torque values, and maintenance schedules.
6. **Power Tool Safety:** When using power tools, keep fingers away from moving parts, and avoid wearing loose clothing or jewelry that may get caught. Always disconnect the power source before changing accessories or making adjustments.
7. **Proper Tool Handling:** Carry sharp or pointed tools with their tips pointing downward, and never run with tools in your hands. Keep tools away from the edge of workbenches to prevent accidental falls.
8. **Tool Cleaning and Lubrication:** Regularly clean tools after use to remove dirt and debris. Apply appropriate lubricants to keep moving parts working smoothly. Well-maintained tools last longer and operate more safely.
9. **Electrical Tool Safety:** If using electrical tools, ensure cords are in good condition and not damaged. Avoid using extension cords that are too long or not rated for the tool's power requirements.
10. **Proper Tool Transportation:** When transporting tools, use toolboxes or carry cases to secure them. This prevents damage to the tools and reduces the risk of injury while moving them around.

As drone technicians, we have the responsibility to operate drones safely and efficiently. Drones offer numerous benefits, but they also pose certain hazards that must be carefully managed. This Toolbox Talk will highlight some common hazards associated with drone operations and the safety measures we need to take.

Pre-flight Inspection: Always conduct a thorough pre-flight inspection of the drone before each operation.

- ☞ Check the battery, propellers, motors, and other critical components for any signs of damage or wear.
- ☞ Verify that all safety features and fail-safe mechanisms are functional.

Weather Conditions: Do not fly the drone in adverse weather conditions, such as strong winds, rain, or lightning. Monitor weather forecasts and be prepared to postpone operations if conditions are not suitable.

Obstacles and Hazards: Identify potential obstacles and hazards in the flight path before take-off. Avoid flying near power lines, tall structures, or other potential collision risks.

Battery Safety: Always use the manufacturer-recommended batteries and chargers. Follow proper charging procedures and never leave batteries unattended during charging. Dispose of damaged or malfunctioning batteries according to guidelines.

Communication: Maintain clear communication with other team members during flight operations. Designate a spotter to help maintain line-of-sight and ensure a safe operating area.

Emergency Procedures: Have a clear plan for emergency situations, including drone malfunctions or signal loss. Know how to activate the drone's return-to-home feature if needed.

Privacy and Permissions:

Respect people's privacy and comply with all local laws and regulations regarding drone operations. Obtain necessary permissions and permits before flying in restricted or private areas.

Battery Management:

Store batteries in a cool, dry, and fire-resistant area when not in use. Do not overcharge batteries, and avoid depleting them completely during flight.

By following these safety considerations and best practices, we can ensure the safe operation of drones and protect ourselves, our colleagues, and the environment. Let's always prioritize safety and adhere to the guidelines provided in our drone operation protocols.

Types of Hazards for Drone Technicians:

Electrical Hazards: Associated with drone battery charging and handling, which can lead to shocks, burns, or fire.

Mechanical Hazards: Risks during propeller installation, maintenance, and repairs, causing cuts or crush injuries.

Environmental Hazards: Weather conditions like strong winds, rain, and lightning that can lead to drone crashes or accidents.

Collisions and Obstacles: Hazards related to collisions with structures, power lines, or other drones in the vicinity.

Privacy and Legal Hazards: Breaching privacy laws or operating drones in restricted areas may lead to legal consequences.

Loss of Control: Signal interference or technical issues can cause drones to lose control during flight.

Battery-Related Hazards: Incorrect battery handling, overcharging, or using damaged batteries can result in fires or explosions.

Falling Debris: During drone maintenance or repairs, parts or tools may fall from heights, causing injuries.

Chemical Hazards: Exposure to hazardous chemicals or substances while working on specialized drones or payloads.

Drone technicians must be trained to identify and address these hazards, follow safety protocols, and wear appropriate personal protective equipment (PPE) to minimize risks during drone operations and maintenance.

DIFFERENT SAFETY PRACTICES

Risk for a Drone Technician

A drone technician may require to repair the propeller, motor and its mount, battery, mainboards, processor, booms, avionics, camera, sensors, chassis, wiring and landing gear. A technician may face some risks while repairing the drones' equipment.

- ☞ The technician is susceptible to being physically harmed by propellers.
- ☞ Direct contact with exposed electrical circuits can injure the person.
- ☞ if the skin gets in touch with the heat generated from electric arcs, it burns the internal issues.
- ☞ Major electrical injuries can occur due to poorly installed electrical equipment, faulty wiring, overloaded or overheated outlets, use of extension cables, incorrect use of replacement fuses, use of equipment with wet hands, etc.

WORKPLACE WARNING SIGNS

A Hazard sign is defined as information or instruction about health and safety at work on a signboard, an illuminated sign or sound signal, a verbal communication or hand signal.

There are four different types of safety signs:

- Prohibition / Danger Alarm Signs
- Mandatory Signs
- Warning Signs
- Emergency

Prohibition / Danger Alarm Signs: A "prohibition sign" is a safety sign that prohibits behaviour that is likely to endanger one's health or safety. The

colour red is necessary for these health and safety signs. Only what or who is forbidden should be displayed on a restriction sign.



Fig.4.1 Prohibition Warning Signs

Mandatory Signs: Mandatory signs give clear directions that must be followed. The icons are white circles that have been reversed out of a blue circle. On a white background, the text is black.



Fig. 4.2 Mandatory Signs

Warning Signs: Warning signs are the safety information communication signs. They are shown as a 'yellow colour triangle'.



Fig. 4.3 Warning Signs

Emergency:

The location or routes to emergency facilities are indicated by emergency signs. These signs have green backdrop with a white emblem or wring. These signs convey basic information and frequently refer to housekeeping, company procedures, or logistics.



Fig.4.4 Emergency Signs

Practical Exercise

3. Identify three specific hazards or risks that drone service technicians may encounter in their workplace.
4. As a drone service technician, why do you think having clear and visible warning signs is crucial in the workplace?

CHECK YOUR PROGRESS

A. Fill in the blank

1. Drone service technicians may face **mechanical hazards** while handling moving parts, rotating propellers, or motorized components, which can result in injuries if not properly secured.
2. **Electrical hazards** may arise when working with electrical components and power systems, leading to the risk of, short circuits, or electrical fires.
3. Working with **chemical cleaning agents**, maintenance chemicals, or battery-related substances may pose risks if not handled correctly, leading to potential health issues or chemical burns.
4. **Lithium Polymer (LiPo)** batteries used in drones can be a specific hazard due to their sensitivity to mishandling, overcharging, or damage, potentially causing thermal runaway and fire.

B. Multiple Choice Questions

1. What are the potential hazards you may encounter while working as a drone technician?
 - A) Electrical hazards
 - B) Mechanical hazards
 - C) Chemical hazards
 - D) **All of the above**
2. Why is it essential to wear appropriate personal protective equipment (PPE) while working with drones?
 - A) To look professional

- B) To comply with company rules
- C) To prevent injuries and health risks**
- D) PPE is not necessary for drone technicians
3. What is one of the main safety concerns related to lithium polymer (LiPo) batteries used in drones?
- A) Risk of electric shock
- B) Risk of fire if mishandled or damaged**
- C) Risk of short circuits
- D) LiPo batteries do not pose any safety concerns
4. What precautions should you take when working with moving parts or rotating propellers on a drone?
- A) Always work with the drone powered on
- B) Properly secure moving parts before handling**
- C) Wear gloves only if the parts are greasy
- D) Speed up the propellers to avoid accidents
5. Why is it crucial to inspect the drone and equipment before each operation?
- A) To check if there are any hidden cameras
- B) To ensure the drone is ready for takeoff
- C) To identify and address any damage or issues**
- D) Inspections are not necessary for drone technicians
6. What are some environmental hazards drone technicians might face during outdoor operations?
- A) Extreme temperatures
- B) Rain or snow
- C) Strong winds
- D) All of the above**

7. What safety measures should be taken to protect against radio frequency (RF) exposure during drone operations?
- A) RF exposure is not a concern for drone technicians
 - B) Avoid staying close to the transmitter and receiver**
 - C) Wear hearing protection
 - D) All drone operations should be conducted indoors

C. Short Answer Question

1. Why is continuous safety training and awareness essential for drone service technicians?
2. Explain the significance of maintaining a clean and organized work area for drone service technicians.
3. How can drone service technicians protect themselves from noise exposure during drone operations?
4. Why is it essential for drone service technicians to be aware of the potential electrical hazards during their work?
5. How can foreign object debris (FOD) impact drone operations, and how can you prevent it?

SESSION 2: PPE KIT SAFETY TOOLS AND SAFETY

Workshop or building where tools and machines are used for making or repairing things. Portable. Includes suspension for easy manual handling, e.g., in connection with spring-suspended portable apparatus for use along assembly lines. Working on assemblies and jobs with hand tools and instruments, mostly on workbenches, is generally referred to as 'Fitting work.' A fitting work is required when different parts are to be assembled in position after they have been finished, and the alignment of machine parts, bearings, engine slide valves, and similar other works call for a fitter's work. All the above types of work require the use of a large number of hand tools, and a fitter must have a good working knowledge of all these tools and instruments.

PERSONAL PROTECTIVE EQUIPMENT

Personal Protective Equipment, or "PPE," is equipment worn to reduce exposure to risks that might result in significant occupational injuries or illnesses. Chemical, Radiological, Physical, Electrical, Mechanical, and other job dangers may cause these injuries and diseases.

Establish and Follow Safe Work Procedure

First Aid Kit

1. Wash the injuries/wounds with clean water
2. Apply First Aid on burns \injuries \wounds
3. Apply Sodium Hydroxide (NaOH) solution when burns are due to the battery's acid

Use and Maintain Personal Protective Equipment (PPE)

1. Importance of Personal Protective Equipment: PPE
2. Eye \Ear Protection
3. Head Protection
4. Foot and Leg Protection
5. Hand and Arm Protection
6. Safety Belt \Body Harness and Overalls (Full Body Suit)

PERSONAL PROTECTIVE EQUIPMENT (PPE)

PPE means personal protective equipment or equipment you use to guarantee your (own) safety. Use PPE always and anywhere where necessary. Observe the instructions for use, maintain them well, and check regularly if they still offer sufficient protection. PPE refers to the equipment which protects the user from health hazards or safety risks at work. It includes Safety Shoes, Safety Helmets, footwear, goggles, etc. Personal Protective Equipment should be provided to all employees who are exposed to safety and health risks at work. In the automobile industry, workers frequently move from one workplace to another and perform a variety of tasks. The employee should be trained on how and when to use protective equipment.

1. Safety for The Head

Wearing a helmet offers protection and can prevent head injuries. Select a sturdy helmet that is adapted to the working conditions. These days, you can find many elegant designs, and you can choose extra options such as an adjustable interior harness and comfortable sweatbands.



Fig. 4.5: Safety for The Head

2. Protect Your Eyes

The eyes are the most complex and fragile parts of our body. Each day, more than 600 people worldwide sustain eye injuries during their work. Thanks to a good pair of safety glasses, these injuries could be prevented. Do you come into contact with bright light or infrared radiation? Then welding goggles or a shield offer the ideal protection!

Eye Protection

Protecting the eyes is extremely important because even a minor accident can cause long-term eye damage or even blindness. Here are several of the most common types of eye protection equipment:

Goggles - This is good for preventing objects from flying into the eyes such as sawdust, stones, and shards of glass.

Welding Masks - While welding masks sometimes cover the entire face, their main function is to protect the eyes from the extremely bright light of a torch. These masks are darkened significantly to prevent the light from reaching and damaging the eyes.

Sunglasses - This is a simple type of PPE that most people never give a second thought. If you're regularly working in the sun or around bright lights, wearing sunglasses can help prevent many eye conditions down the road.

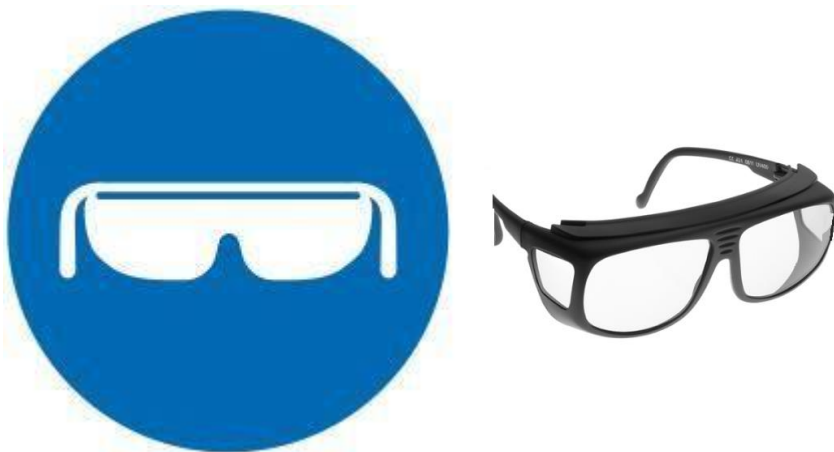

Fig 4.6: Protect Your Eyes

3. Hearing Protection

Do you work in an environment with high sound levels? In that case, it is very important to consider hearing protection. Earplugs are very comfortable, but earmuffs are convenient on the work floor as you can quickly put these on or take them off.

Ear Plugs - Ear plugs are easy to use and provide a fair amount of protection by preventing loud noises from entering the ear at all.

Ear Muffs - Ear muffs go over the entire ear, and when worn properly, can provide a significant amount of noise reduction.

Electronic Ear Muffs - These advanced hearing protection devices work like ear muffs to stop the noise from coming in, but also have an electronic microphone that picks up voices and other noises and then plays them into the ear so people can still hear. The sounds are played at a low level so they do not cause damage.



Fig. 4.7: Hearing Protection

4. Maintain a Good Respiration

Respirators

Respirators are a type of personal protective equipment designed specifically to protect the lungs of the people wearing them. They can help filter out dust, debris, chemicals, and many other potential dangers. There are many types of respirators used for PPE, including:

Basic Facemask - A facemask can minimize the risk of exposure to simple biological contaminants, dust, debris, and other harmful impurities in the air. In a pinch, even a simple handkerchief could serve as a facemask (though not recommended for regular use).

Filtered Respirator - If there are known impurities that can cause serious damage or illness, having a filter on the respirator is important. There are

many types of filtered respirators available depending on how many impurities need to be removed.

Self-Contained Breathing Apparatus - In situations where the air is extremely toxic, a self-contained breathing apparatus allows the employee to bring a supply of fresh air with them. This is also used when there is no oxygen to breathe, such as underwater.

Wearing a mask at work is no luxury, definitely not when coming into contact with hazardous materials. 15% of the employees within the EU inhale vapours, smoke, powder or dust while performing their job. Dust masks offer protection against fine dust and other dangerous particles. If the materials are truly toxic, use a full-face mask. This adheres tightly to the face, to protect the nose and mouth against harmful pollution.



Fig.4.8: Maintain a Good Respiration

5. Protect Your Hands with The Right Gloves

Hands and fingers are often injured, so it is vital to protect them properly. Depending on the sector you work in, you can choose from gloves for different applications:



Fig. 4.9: Protect Your Hands with The Right Gloves

Like Protection against vibrations, cuts by sharp materials, cold or heat, bacteriological risks, and Protection against splashes from diluted chemicals.

Plastic Gloves - Plastic (or latex) gloves are among the most common types of skin protection equipment. They can keep a wide range of hazards away, including biological and chemical solutions.

Cut-Resistant Gloves - Employees who work with sharp objects should wear cut-resistant gloves. These gloves are made of special materials that prevent blades from slicing through them.

6. Skin and Body Protection Equipment

Many chemicals and other materials can cause serious injuries or illnesses when they come in contact with the skin. When working with these hazards, having proper personal protective equipment is extremely important.

Protective Clothing - The most common type of skin protection equipment is general protective clothing. Something as simple as a lab coat helps reduce the risk of getting splashed with potentially hazardous solutions. While it isn't a high level of protection, it is sufficient for many situations.

Heat-Resistant Clothing - When working with fire or other high-temperature hazards, employees should wear heat-resistant clothing. This could be heat-resistant gloves or it could be an entire suit, depending on the

situation. Preventing accidents is crucial in a crowded workshop. That is why a good visibility at work is a must: a high-visibility jacket and pants made of a strong fabric can help prevent accidents. Just like hand protection, there are versions for different applications.



Fig. 4.10: Wear the Correct Work Clothing

Electricity-Resistant Clothing - When working with or around high voltage areas, having PPE that can reduce the risk of electrical shock is essential. This could be rubber boots, gloves, or an entire body suit.

Face Shields - Face shields reduce the risk of having something splash up into the face, causing damage. Whether working with hot items, corrosive materials, or biological materials, face shields can protect one of the most vulnerable parts of the body.

Hard Hats - Hard hats are a great way to keep someone's head safe when working in an area where something could fall on

7. Protection for The Feet

Even your feet need solid protection. Safety shoes (type Sb, S1, S2, or S3) and boots (type S4 or S5) are the ideal solutions to protect the feet against heavyweights. An antiskid sole is useful when working in a damp environment, definitely if you know that 16,2% of all industrial accidents are caused by tripping or sliding. On slippery surfaces, such as snow and ice, shoe claws are recommended. Special socks can provide extra comfort.



Fig.4.11: Protection for the feet

8. Safety sign



Fig.4.12 Safety sign

Worst-Case Scenario

Prevention is better than cure. A smart thing is to be prepared for the worst. A classic first-aid kit is no luxury but a first-aid kit for the eyes can also be

an essential first aid. If the employee comes into contact with chemicals, a safety shower is mandatory, so that he can rinse the substances off his body at any moment.

When working with drones, technicians and operators may encounter various hazards that can pose risks to health, safety, and the environment. Understanding these hazards is essential to ensuring safe drone operations.

Major Safety Hazards

1. Physical Hazard
2. Electrical Hazard
3. Chemical Hazard

1. Physical Hazards: Physical hazards involve risks that arise from mechanical components, moving parts, and environmental conditions. Some key physical hazards in drone operations include:

1.1. Explosive

If exposed to high temperature, heat, shock, or friction, it may explode.

- Avoid sources of ignition (sparks, flames, heat)
- Maintain your distance.
- Kept on protective clothing.



1.2. Flammable

Flammable if exposed to ignition sources, sparks, or heat. Some substances with this symbol may give off flammable gases in contact with water.

- Avoid ignition sources (sparks, flames, heat)
- Keep your distance
- Wear protective clothing



1.3 Oxidising

Can burn even without air, or can intensify fire in combustible materials.

- Avoid ignition sources (sparks, flames, heat)
- Keep your distance
- Wear protective clothing



1.4 Gas under Pressure

Contains gas under pressure. The gas released may be very cold. The gas container may explode if heated.

- Do not heat containers
- Avoid contact with skin and eyes



1.5 Corrosive

- May corrode metals.
- Keep away from metals



Physical Hazard – Personal Protection

Physical Hazard – Personal Protection

- Protective Helmet
- Earmuffs
- Earplugs
- Safety glasses
- Goggles
- Face shield
- Footwear

Rotating Propellers – Drone propellers spin at high speeds and can cause cuts or serious injuries if handled carelessly.

Heavy Drone Components – Large industrial drones or their batteries can be heavy, leading to the risk of strain injuries or accidents if not handled properly.

Collision and Impact Risks – Drones may crash into objects, buildings, or people, causing damage, injury, or equipment failure.

Falling Hazards – Drones flying overhead can malfunction and fall, posing a threat to people below.

Summary of physical hazards

- Provide a variety of physical safety problems throughout production and maintenance operations, in addition to chemical-related health and safety concerns:

- Equipment servicing, cleaning, adjustment, and/or repair exposes workers to a variety of hazardous energies, including electrical, hydraulic, and mechanical. To avoid electrocution, amputation, or crushing accidents, well-written hazardous energy control measures must be implemented and trained on. To prevent unintended contact by production and maintenance personnel, exposed belts, wheels, and other rotating machinery on conveyors or other production equipment must be properly guarded.

2. Electrical Hazard: An electrical hazard is a serious workplace hazard that can cause burns, electrocution, shock, arc flash/arc blast, fire, or explosions. We can protect ourselves by identifying these hazards and understanding how they occur. Although much of the public may think radiation from the sun is magically transformed into electricity that powers all types of equipment and devices, solar technicians know there is much more to it.

Key points to remember

Battery Explosions and Fires – Drones use Lithium-Polymer (Li-Po) batteries, which are highly sensitive and can overheat, catch fire, or explode if damaged or improperly charged.

Short Circuits – Faulty wiring, water exposure, or improper connections can cause short circuits, leading to power failure or fire hazards.

Electrostatic Discharge (ESD) – Handling sensitive electronic components without ESD protection can damage circuits, affecting drone performance.

Electrical Shock – Improper handling of battery terminals, chargers, or power sources can result in electric shocks to the technician.

4. **Chemical:** Chemical hazards arise from exposure to harmful substances during drone servicing, maintenance, and operation.

These include-

Battery Leakage – Damaged or old Li-Po batteries can leak toxic and flammable chemicals, which may cause skin burns, respiratory issues, or fire hazards.

Cleaning and Maintenance Fluids – Some lubricants, solvents, and adhesives used in drone repair may release harmful fumes, leading to health risks if inhaled.

Pesticide or Chemical Sprays – Agricultural drones used for spraying fertilizers and pesticides can pose chemical exposure risks to operators if proper protective gear is not used.

Safety Measures to Prevent Hazards

- Use Personal Protective Equipment (PPE) such as gloves, goggles, and ESD protection kits.
- Follow Proper Battery Handling Guidelines to prevent overheating, short circuits, and leaks.
- Conduct Pre-flight Safety Checks to ensure the drone and its components are functioning correctly.
- Operate Drones in Safe Areas away from crowds, power lines, and hazardous environments.
- Dispose of Batteries and Chemicals Properly to minimize environmental risks.

Practical Exercise

1. Sketch a personal protective Equipment kit.

CHECK YOUR PROGRESS

A. Fill in the blank

1. Workshop where tools andare used for making or repairing things. **Machines**
2. PPE refers to the equipment which the user from health hazards orat work. **Protects, safety risks**
3. Wearing a helmet offers protection and can prevent **Head injuries**
4. Theare the most complex and fragile parts of our body. **Eyes**

B. Multiple Choice Question

1. welding mask's main function is to protect the eyes from the extremely
 - a) **Bright light of a torch**
 - b) the dark light of a torch
 - c) zig-zag current
 - d) one of these
2. Name of sound protection PPE kit
 - a) Ear Plugs
 - b) Ear Muffs
 - c) Electronic Ear Muffs
 - d) **All of these**
3. Respirators are a type of personal protective equipment designed specifically to protect the
 - a) **lungs of the people**
 - b) head of people
 - c) eyes of people
 - d) None of these
4. A face mask can minimize the risk of exposure to simple
 - a) **Dust, Debris, and other harmful impurities**
 - b) sun
 - c) chemical reaction
 - d) head injuries
5. The voltage level supplied to homes in an electrical circuit is usually:
 - a) 110V
 - b) **230V**

- c) 12V
- d) 400V

C. Short Answer Question

1. What type of protective eyewear should a drone technician wear?
2. Why are insulated gloves important when handling drone batteries?
3. Name one essential tool for tightening or loosening drone propellers.
4. Why is a first aid kit necessary for drone technicians?
5. What type of storage box is used for lithium-polymer (LiPo) batteries?

SESSION 3: WASTE MANAGEMENT CONCEPTS

The collection, disposal, monitoring, and processing of waste materials are known as waste management. These wastes affect living beings' health and the environment. For reducing their effects, they have to be managed properly. The waste is usually in solid, liquid, or gaseous form.

The importance of waste management is: Waste management is important because it decreases waste's impact on the environment, health, and other factors. It can also assist in the reuse or recycling of resources like paper, cans, and glass. The disposal of solid, liquid, gaseous, or dangerous substances is an example of waste management.

When it comes to trash management, there are numerous factors to consider, including waste disposal, recycling, waste avoidance and reduction, and garbage transportation. The treatment of solid and liquid wastes is part of the waste management process. It also provides several recycling options for goods that aren't classified as garbage during the process.

METHODS OF WASTE MANAGEMENT:

Non-biodegradable and toxic wastes, such as radioactive remains, can cause irreversible damage to the environment and human health if they are

not properly disposed. Waste disposal has long been a source of worry, with population increase and industrialization being the primary causes. Disposing of hazardous waste requires careful handling and adherence to specific regulations to protect human health and the environment. Improper disposal can lead to severe environmental contamination and health risks. Here are some common methods of disposing hazardous waste-

Landfill Disposal: Hazardous waste can be placed in specially designed and regulated hazardous waste landfills. These landfills have engineered liners and monitoring systems to prevent the waste from contaminating soil and groundwater. The waste is often stabilized or solidified before disposal to minimize its mobility and potential for leaching.

Incineration: Incineration involves burning hazardous waste at very high temperatures in controlled conditions. This method reduces the volume of waste and converts it into ash, gases, and heat. Modern incinerators have advanced pollution control systems to minimize harmful emissions. Incineration is suitable for certain types of hazardous waste, such as organic compounds and flammable materials.

Deep Well Injection: Hazardous waste, particularly liquid waste, can be injected deep into the ground through wells specially designed for this purpose. This method is used when waste cannot be treated or recycled and is considered a last resort option for hazardous waste disposal.

Chemical Treatment: Some hazardous wastes can be treated chemically to neutralize or detoxify them, making them less harmful. Chemical treatment processes may involve precipitation, oxidation, reduction, or other chemical reactions to transform hazardous substances into less hazardous forms.

Physical Treatment: Physical treatment methods involve separating hazardous waste into its constituent parts or reducing its volume. Techniques like distillation, filtration, centrifugation, and evaporation may be used to treat certain types of hazardous waste.

Bioremediation: Bioremediation is a biological treatment method that utilizes microorganisms to break down or transform hazardous substances into less harmful compounds. It is particularly useful for treating certain organic hazardous wastes.

Encapsulation: Encapsulation involves placing the hazardous waste in a solid, stable material, such as concrete or epoxy, to prevent its release into the environment. This method is commonly used for small quantities of hazardous waste or when waste must be temporarily stored before final disposal.

Recycling and Recovery: In some cases, hazardous waste can be recycled or recovered to extract valuable materials. For example, certain electronic waste (e-waste) can be processed to recover valuable metals like gold, silver, and copper.

Secure Chemical Destruction: Some hazardous waste, especially toxic chemicals or expired pharmaceuticals, can be chemically destroyed in specialized facilities. These facilities are designed to safely handle and neutralize hazardous substances.

ELECTRONIC WASTE DISPOSAL

Electronic waste, commonly known as e-waste, refers to discarded electrical or electronic devices. Proper e-waste disposal is essential to prevent environmental pollution and health risks associated with hazardous materials found in electronics.

Electronic Waste Disposal Procedure:

The electronic waste disposal procedure involves several steps to ensure the safe and responsible management of discarded electronic devices. Proper e-waste disposal is crucial to prevent environmental contamination and health risks associated with hazardous materials found in electronics. Below is a step-by-step guide to the e-waste disposal procedure.

Identify E-Waste: Identify the electronic devices that are no longer in use or are damaged beyond repair. Examples of e-waste include computers,

laptops, smartphones, tablets, printers, televisions, refrigerators, washing machines, and other electrical or electronic appliances.

Data Back-up and Data Wiping: Before disposing of any electronic device that stores personal or sensitive data (e.g., computers, smartphones), back up your data to an external storage device or a cloud-based service. After backing up, ensure that all personal data is wiped clean from the device. Use data erasing software or perform a factory reset to remove personal information.

Reuse or Donate: If the electronic device is still in working condition and relatively new, consider reusing it or donating it to charities, schools, or community organizations. Reusing electronics can extend their lifespan and reduce the overall demand for new devices.

Trade-In or Buyback Programs: Some electronics retailers offer trade-in or buyback programs, where they accept old devices and provide incentives or discounts on new purchases. Check with the retailer to see if they have such a program available.

Certified E-Waste Recycler: If the electronic device is no longer usable or suitable for reuse, locate a certified e-waste recycler or recycling facility. Look for organizations or facilities that are accredited by relevant authorities and comply with e-waste recycling regulations.

Drop-off or Collection: Deliver the e-waste to a certified e-waste recycling facility or use designated drop-off points or collection events in your community. Many cities have dedicated e-waste drop-off centers or organize periodic electronic waste collection events.

Disassembly: At the recycling facility, trained technicians disassemble the electronic devices into their individual components. They segregate different materials such as metals, plastics, and glass for proper recycling.

Recycling and Recovery: The recyclable materials are sent for further processing to extract valuable components such as metals (e.g., copper,

gold, silver) and plastics. The extracted materials are then used to manufacture new products, reducing the need for raw materials.

Environmentally Friendly Disposal: Any hazardous materials or components that cannot be recycled, like lead-acid batteries or cathode ray tubes (CRTs), are disposed of in an environmentally friendly manner following hazardous waste regulations.

Compliance and Reporting: Certified e-waste recyclers must comply with reporting requirements, ensuring that they handle and process e-waste responsibly. Compliance with environmental regulations helps monitor and track the recycling process.

Practical Exercise

1. Identify the materials needed for waste management.
2. Identify types of waste in your workshop.

Check your progress

A. Fill in the blank

1. Waste management is the process of **collecting, transporting, treating, and disposing** waste materials to minimize their impact on the environment and human health.
2. The waste management hierarchy consists of five levels: **prevention, minimization, reuse, recycling, and disposal**.
3. Recycling is the process of converting waste materials into reusable products to **reduce** resource consumption and **mitigate** waste disposal.
4. **Composting** is a natural process of decomposing organic waste, such as food scraps and yard trimmings, into nutrient-rich compost that can be used to improve soil quality.
5. Landfills are designated areas for **controlled** waste disposal. They are engineered to minimize environmental **contamination** and health hazards.

B. Multiple Choice Questions

1. What is the primary goal of waste management?
 - a) Maximizing waste generation
 - b) **Reducing waste generation**
 - c) Increasing landfill capacity
 - d) Encouraging littering

2. Which of the following is NOT a part of the waste management hierarchy?
 - a) Prevention
 - b) Reuse
 - c) Recycling
 - d) **Waste Generation**

3. What is the process of converting waste materials into reusable products to reduce resource consumption?
 - a) Composting
 - b) Incineration
 - c) **Recycling**
 - d) Landfilling

4. Which waste management practice converts organic waste into nutrient-rich compost?
 - a) Incineration
 - b) Recycling
 - c) **Composting**
 - d) Landfilling

Answer: C) Composting

5. What is the term for the designated areas where waste is disposed of in a controlled manner?
 - a) Waste Zones
 - b) Disposal Sites
 - c) Incineration Centers

d) Landfills**Answer: d) Landfills****D. Short Answer Question**

1. What is waste management, and why is it important for the environment?
2. What are the main categories of waste, and how are they typically managed?
3. What are the key principles of the waste management hierarchy?
4. How does recycling contribute to waste reduction and resource conservation?
5. What are the challenges and benefits of composting organic waste?

Answer Key**MODULE 01: INTRODUCTION OF DRONES****SESSION 1: INTRODUCTION OF DRONES AND ROLE OF A DRONE SERVICE TECHNICIAN****A. Fill in the Blanks**

1. Drone maintenance and repair
2. Intelligence-gathering
3. fertilizer/ pesticide spray
4. unmanned aerial vehicles
5. Defence Research and Development Organisation

B. Multiple Choice Questions

1. c) Drone maintenance and repair
2. c) Developing drone hardware components
3. b) a & b
4. b) Cleaning and inspecting the drone's components
5. b) Collecting and analyzing data from drone flights

SESSION 2: DRONE TECHNOLOGY AND ITS CLASSIFICATION**A. Fill in the Blanks**

1. Including Size, Shape, and Payload Capacity
2. Micro, Mini, and Large Drones

3. Quadcopters, Hexacopters, and Fixed-Wing Drones
4. Photography, Surveillance, Delivery, Or Other Specific Purposes

B. Multiple Choice Questions

1. a) Size, shape, propulsion, capabilities, and usage
2. a) Nano, micro, mini, and large drones
3. d) Fixed-wing drone
4. a) Photography, surveillance, delivery, and military applications

SESSION 3: BASIC PRINCIPLES OF ELECTRICITY, ELECTRONIC COMPONENTS, HARDWARE AND SOFTWARE OF DRONE**A. Fill in the Blanks**

1. Negative
2. Amperes (A)
3. Electric potential difference
4. Ohms (Ω)
5. Inversely

B. Multiple Choice Questions

1. c) Positive or negative
2. b) Electric current
3. c) Volts (V)
4. a) Ohms (Ω)
5. b) $V = I / R$ a) Navigation System
6. a) The sum of individual resistances
7. a) The sum of individual voltages

MODULE 02: TOOLS FOR DRONE TECHNICIAN**Session 1: Mechanical Tools****A. Fill in the Blanks**

1. Propeller
2. Tweezers

3. Pliers
4. Calipers
5. Propeller removal tool
6. Lubricants, Grease
7. Desoldering
8. Cleaning brushes
9. Thread locking compounds
10. Screwdrivers

B. Multiple Choice Questions

1. b) Multimeter
2. a) Anti-Static Wrist Strap and Mat
3. c) Wire Crimpers
4. c) Oscilloscope
5. c) Battery Discharger
6. b) Magnifying Glass
7. c) Signal
8. c) Soldering Iron
9. d) Velcro Straps and Cable Ties

SESSION 2: ELECTRICAL TOOLS

A. Fill in the blank

1. Multimeter
2. Anti-Static Wrist Strap and Mat
3. Soldering Iron and Solder
4. Oscilloscope
5. Battery Discharger
6. Deans/T-Plug, Crimping Tool

B. Multiple Choice Questions

1. b) Multimeter
2. a) Anti-Static Wrist Strap and Mat
3. c) Wire Crimpers
4. c) Oscilloscope
5. c) Battery Discharger

SESSION 3: SAFETY TOOLS FOR DRONE TECHNICIAN

B. Fill in the Blanks

1. Electrical
2. Batteries
3. Insulated
4. Debris
5. Ventilation
6. Falls
7. Safety
8. Helmet
9. Electrical
10. Harness

B. Multiple Choice Questions

1. b) To prevent electrical hazards
2. c) To minimize risks of accidents
3. a) Safety goggles
4. b) Overheating and fire hazards
5. a) To prevent overheating
6. b) High visibility vest
7. b) Full-body harness
8. b) To protect the head from injuries
9. b) To reduce noise hazards
10. b) Cotton gloves

SESSION 4: ELECTRICAL PARAMETERS**A. Fill in the Blanks**

1. Ampere
2. Voltage
3. Ohms
4. Electrical
5. Watt
6. Energy
7. DC
8. DC
9. AC
10. Rectifier

B. Multiple Choice Questions

1. c) Ampere
2. b) Voltage
3. c) Resistance
4. a) $P = V \times I$
5. a) 1 Joule per second
6. b) Does not change

7. c) Rectifier
8. b) AC
9. b) DC
10. b) 230V

MODULE 03: MAJOR COMPONENTS OF DRONE

SESSION 1: MAJOR COMPONENTS OF THE DRONE

A. Fill in the Blanks

1. Frame
2. Propellers
3. Motors
4. Electronic Speed Controllers (ESCs)
5. Flight Controller

B. Multiple Choice Questions

1. c) To hold all the components together
2. b) Propellers
3. d) Aluminum
4. d) To control the speed and direction of the motors
5. c) Flight Controller
6. c) Lithium-Polymer (LiPo) Battery
7. c) Remote Controller
8. d) Gimbal
9. a) Return-to-Home function
10. c) Onboard Computer

SESSION 2: ELECTRIC AND ELECTRONIC COMPONENTS OF THE DRONE

A. Fill in the Blanks

1. Flight Controller
2. Electronic Speed Controllers (ESCs)

3. Transmitter, Receiver
4. GPS
5. Telemetry
6. Computer
7. Sensors
8. Gimbal
9. Wi-Fi
10. Visual

B. Multiple Choice Questions

1. b) To stabilize flight and process sensor data
2. b) Electronic Speed Controllers (ESCs)
3. b) Providing accurate positioning data
4. c) It allows real-time data transmission
5. b) Receiver and Transmitter
6. c) To ensure smooth and stable camera movement
7. c) Barometer
8. b) To enhance visibility and indicate status
9. b) Wi-Fi Module
10. a) Processing complex flight patterns and autonomous navigation

SESSION 3: TAKE OFF AND LANDINGS OF DRONE**A. Fill in the Blanks**

1. Pre-Flight Check
2. Flight Controller
3. Thrust
4. Flat and Open Area
5. Battery
6. Manufacturer's Guidelines
7. Altitude Control
8. Runway
9. Ultrasonic Sensors
10. Damage

B. Multiple Choice Questions

1. b) To ensure all drone components are functioning correctly
2. c) Gyroscopes and accelerometers
3. c) Turning off GPS before takeoff
4. b) To ensure a stable and safe launch
5. b) Gradually increase the throttle
6. c) Plan a gentle descent path
7. b) LiDAR

8. b) To ensure sufficient charge for a safe descent
9. b) Power off the drone and remote controller
10. b) Post-flight check

MODULE 4: WORK AND SAFETY

SESSION 1: TOOLS BOX TALK AND DIFFERENT TYPES OF HAZARDS

A. Fill in the Blanks

1. Mechanical Hazards
2. Electrical Hazards
3. Chemical Cleaning Agents
4. Lithium Polymer (Lipo)

B. Multiple Choice Questions

1. d) All of the above
2. c) To prevent injuries and health risks
3. b) Risk of fire if mishandled or damaged
4. b) Properly secure moving parts before handling
5. c) To identify and address any damage or issues
6. d) All of the above
7. b) Avoid staying close to the transmitter and receiver

SESSION 2: PPE KIT SAFETY TOOLS AND SAFETY

A. Fill in the Blanks

1. Machines
2. Protects, safety risks
3. Head injuries
4. Eyes

B. Multiple Choice Questions

1. a) Bright light of a torch
2. d) All of these
3. a) Lungs of the people
4. a) Dust, Debris, and other harmful impurities
5. b) 230V

SESSION 3: WASTE MANAGEMENT CONCEPTS**A. Fill in the Blanks**

1. collecting, transporting, treating, and disposing
2. prevention, minimization, reuse, recycling, and disposal.
3. Reduce, mitigate
4. Controlled, contamination

B. Multiple Choice Questions

1. Reducing waste generation.
2. Waste Generation.
3. Recycling.
4. Composting.
5. Landfills.

ABBREVIATION

AC: Alternating current

UAV: Unmanned Aerial Vehicle

UAS: Unmanned Aircraft System

RPAS: Remotely Piloted Aircraft System

RPA: Remotely Piloted Aircraft

RPIC: Remote Pilot in Command

VLOS: Visual Line of Sight

BVLOS: Beyond Visual Line of Sight

GPS: Global Positioning System

RTK: Real-Time Kinematic

FPV: First-Person View

LiDAR: Light Detection and Ranging

ESC: Electronic Speed Controller

FC: Flight Controller

PPK: Post-Processed Kinematic

GIS: Geographic Information System

NDVI: Normalized Difference Vegetation Index

SLAM: Simultaneous Localization and Mapping

LOS:	Line of Sight
IMU:	Inertial Measurement Unit
GSD:	Ground Sample Distance
GCP:	Ground Control Point
AoA:	Angle of Attack
LiPo:	Lithium-Polymer Battery
ROI:	Return on Investment
CAA:	Civil Aviation Authority
NOTAM:	Notice to Airmen
LandD:	Launch and Delivery
RTH:	Return to Home
SOP:	Standard Operating Procedure
COA:	Certificate of Authorization
DC:	Direct current
Kw/Kwh:	Kilowatt/kilowatt-hour
MW/MWh:	Megawatt/megawatt-hour
VFD:	variable-frequency drive
W/Wh:	Watt/watt-hour
Wp:	Peak Watt, also known as Watt-peak\

GLOSSARY

Alternating Current (Ac) — a type of electrical current, the direction of which is reversed at regular intervals or cycles.

Ampere (Amp) — a unit of electrical current or rate of flow of electrons.

Battery — Two or more electrochemical cells enclosed in a container and electrically interconnected in an appropriate series/parallel arrangement to provide the required operating voltage and current levels. Under common usage, the term battery also applies to a single cell if it constitutes the entire electrochemical storage system.

Battery Capacity — The maximum total electrical charge, expressed in ampere-hours, which a battery can deliver to a load under a specific set of conditions.

Battery Cell — The Simplest Operating Unit in A Storage Battery.

Battery Life — The Period During Which a Cell or Battery Is Capable of Operating Above a Specified Capacity or Efficiency Performance Level. Life May Be Measured in Cycles and/or Years, depending on the Type of Service for Which the Cell or Battery Is Intended.

Drone: An unmanned aerial vehicle (UAV) or unmanned aircraft that can be remotely controlled or operate autonomously.

Drone Service Technician: A professional who specializes in operating, maintaining, and troubleshooting drones for various applications.

Remote Pilot: A person who controls a drone's flight using a remote controller or a ground-based control station.

Payload: The equipment or sensors carried by a drone, such as cameras, LiDAR, thermal imagers, or other specialized tools.

LiDAR: Light Detection and Ranging is a technology that uses laser pulses to measure distances, commonly used for creating high-resolution 3D maps.

FPV (First-Person View): A method that allows the drone operator to see

the drone's perspective in real-time through a live video feed transmitted from the drone's camera.

RTK (Real-Time Kinematic): A satellite navigation technique used to enhance the precision of the drone's positioning data.

Waypoints: Pre-defined GPS coordinates that are programmed into the drone's flight path, allowing it to fly along a predetermined route.

Gimbal: A stabilized camera mount that allows the camera to maintain a level horizon, even if the drone tilts or moves.

ESC (Electronic Speed Controller): A device that regulates the speed of the drone's motors based on signals from the flight controller.

Flight Controller: The main onboard computer system that manages the drone's flight, navigation, and stabilization.

Remote Sensing: The process of gathering data from a distance, often using sensors on a drone to collect information about the environment.

Resistance (R) — the property of a conductor, which opposes the flow of an electric current

Georeferencing: The process of associating data collected by the drone with specific geographic coordinates to create accurate maps or models.

Point Cloud: A collection of 3D points generated by LiDAR or photogrammetry, used to create detailed 3D models of terrain or structures.

Photogrammetry: A technique that uses photographs taken from different angles to create 3D models or maps of objects or landscapes.

GIS (Geographic Information System): A system that stores, analyzes, and displays geographic data, often used to process drone-acquired data.

BVLOS (Beyond Visual Line of Sight): Refers to drone operations conducted outside the pilot's direct visual range, often requiring special permissions and technology.

NOTAM (Notice to Airmen): Information issued by aviation authorities to

alert drone operators to potential hazards or operational restrictions in a specific area.

LiPo Battery (Lithium-Polymer Battery): A common type of battery used in drones due to its high energy density and lightweight characteristics.

UTM (Unmanned Traffic Management): Systems and technologies designed to manage and integrate drone traffic into the airspace safely.

Conductor — The material through which electricity is transmitted, such as an electrical wire, or transmission or distribution line.

Deep Discharge — Discharging a battery to 20% or less of its full charge capacity.

Electric Current — The flow of electrical energy (electricity) in a conductor, measured in amperes.

Load — The Demand on an Energy-Producing System

Ohm — A Measure of the Electrical Resistance of a Material Equal to The Resistance of a Circuit in Which the Potential Difference of 1 Volt Produces A Current Of 1 Ampere.